

# C&I Sigen Inverter & Sigen Battery Energy Storage System

## User Manual

Version: 03

Release date: 2026-03-06



## Copyright Notice

Copyright© 2026 SigenergyTechnology Co., Ltd. All Rights Reserved.

Description in this document may contain predictive statements regarding financial and operating results, product portfolio, new technology, configurations and features of product. Several factors could cause difference between actual results and those expressed or implied in the predictive statements. Therefore, description in this document is provided for reference purpose only and constitutes neither an offer nor an acceptance. Sigenergy Technology Co., Ltd. may change the information at any time without notice.



**SIGENERGY** and other Sigenergy trademarks are owned by Sigenergy Technology Co., Ltd.

All trademarks and registered trademarks in this document belong to their owners.



Website



LinkedIn



YouTube

[www.sigenergy.com](http://www.sigenergy.com)

# Contents

<b>Revision History .....</b>	<b>05</b>
<b>Preface .....</b>	<b>06</b>
<b>Chapter 1 Safety Precautions .....</b>	<b>07</b>
1.1 General Requirements .....	07
1.2 Personnel Requirements .....	09
<b>Chapter 2 Handling and Transportation Requirements .....</b>	<b>10</b>
2.1 Routine Requirements .....	10
2.2 Battery Pack .....	11
<b>Chapter 3 Storage Requirements .....</b>	<b>13</b>
<b>Chapter 4 Operation Requirements .....</b>	<b>15</b>
4.1 Equipment Installation .....	17
4.2 Cable Connections .....	19
4.3 Safety Tips for Working at Heights .....	20
4.4 Equipment Maintenance and Replacement .....	21
<b>Chapter 5 Introduction to energy storage system .....</b>	<b>22</b>
5.1 Product Introduction .....	22
5.1.1 Sigen Inverter .....	22
5.1.2 SigenStack Energy Storage System .....	24
5.1.3 Sigen Power Sensor .....	25
5.1.4 Sigen Communication Module .....	26
5.1.5 Sigen Communication Bridge .....	27
5.2 Appearance Introduction .....	28
5.2.1 Sigen PV (50–125)M1 Inverter .....	28
5.2.2 Sigen PV (50–110)M1-HYA Inverter .....	30
5.2.3 Sigen PV 125M1-HYA Inverter .....	32
5.2.4 Sigen PV (50–110)M1-HYB Inverter .....	34
5.2.5 Sigen PV 100M1-HYB-JP .....	36
5.2.6 Sigen PV (150–166)M1,(150–166)M2 Inverter .....	38
5.2.7 SigenStack Energy Storage System .....	40

5.2.8 Sigen Communication Bridge .....	41
5.3 Label Description .....	42
5.4 Supported Power Supply Methods for the Power Grid .....	43
5.5 System wiring introduction .....	44
<b>Chapter 6 Location Requirements .....</b>	<b>49</b>
<b>Chapter 7 System Operation .....</b>	<b>53</b>
7.1 Operational Mode .....	53
7.2 LED Indicator State .....	56
<b>Chapter 8 Equipment Installation and Wiring .....</b>	<b>63</b>
<b>Chapter 9 mySigen App Query .....</b>	<b>64</b>
<b>Chapter 10 System Maintenance .....</b>	<b>65</b>
10.1 Routine Maintenance .....	65
10.2 System Power-on/Power-off .....	67
10.3 Low SOC .....	69
10.4 Emergency Treatment .....	70
<b>Chapter 11 Inverter and Battery Pack Disposal .....</b>	<b>72</b>
<b>Chapter 12 Appendix .....</b>	<b>73</b>

# Revision History

Version	Date	Description
03	2026.03.06	Update <a href="#">LED Indicator State</a>
02	2025.11.21	Update <a href="#">Storage Requirements</a> Update <a href="#">Introduction to energy storage system</a>
01	2025.06.25	First official release.

# Preface

## Overview

This document mainly describes the product information, system wiring, and system operation and maintenance of C&I PV storage system.



## Intended Audience

This document is intended for:

- Professionally trained and qualified installers.
- Technical support engineers.

## Definitions of Signs

The following signs may be used in the document to indicate safety precautions or key information. Before installation and operation of the equipment, familiarize yourself with signs and their definitions.

Sign	Definition
 <b>Danger</b>	Danger. Indicates an imminently hazardous situation which, if not avoided, will result in death or serious personal injury.
 <b>Warning</b>	Warning. Indicates a potentially hazardous situation which, if not avoided, will result in serious personal injury or property damage.
 <b>Caution</b>	Caution. Indicates a potentially hazardous situation which, if not avoided, will result in property damage.
<b>Tips</b>	Indicates important or key information and provides operation tips.

# Chapter 1 Safety Precautions

## 1.1 General Requirements

Before installing, operating, and maintaining the equipment, familiarize yourself with this user manual. Strictly follow the instructions in the manual and adhere to all safety precautions indicated on the equipment and within the manual.

The "Danger," "Warning," and "Caution" statements described in this manual are only supplementary precautions to all safety notices.

The Company shall not be held liable for equipment damage or property loss resulting from violation of safety operation requirements or safety standards of design, production, and use of equipment, including but not limited to the following:

- The installation environment does not comply with relevant international, national, or regional standards.
- Failure to comply with local laws and regulations during the transportation, installation, operation, and maintenance of the equipment.
- The installation area does not meet the requirements of the equipment.
- Cables, tools, and other materials used do not comply with relevant international, national, or regional standards.
- Operation connected to the grid without obtaining permission from the power authorities of the country or region where it is located.
- Damage caused by storage conditions that do not meet the requirements of the equipment.
- Failure to operate according to the instructions and precautions in the manual.
- Failure to follow the prescribed sequence of steps for installation, operation, and maintenance in the manual, unauthorized changes to the installation sequence, unauthorized modification, additions, or changes to equipment, etc.
- Do not install other equipment on top of the equipment without our evaluation.
- Failure to handle the equipment with care or violent installation may result in equipment damage and liquid leakage and pose a risk of fire or explosion hazards.
- Failure to follow the operational requirements indicated on warning labels on the equipment or tools.
- Negligence, improper operation, or deliberate damage.
- Damage caused during transportation by you or a third party you commission.
- Damage caused by the change of the scenarios for which the equipment is intended on the customer or a third party company side.
- Equipment damage caused by failure to use the accessories supplied with the packing box or purchase and use accessories of the same specification on the customer or a third-party company side.
- Equipment damage caused by unauthorized disassembly or replacement of the equipment or modification of software code, or other improper operations.

- Equipment damage caused by force majeure (such as war, earthquake, fire, storms, lightning, floods, and debris flow).
- Damage caused by the failure of the natural environment or external power parameters to meet the standard requirements for the normal operation of the equipment. For example, the actual operating temperature of the equipment is too high or too low.
- The equipment is stolen.
- The equipment is damaged after the warranty period expires.
- It is strictly forbidden for fingers, parts, screws, tools, or boards to touch the running fan to avoid injury to hands or damage to the equipment.
- Some loads may have a relatively high starting power and starting current. Customers must check whether the starting power of the load exceeds the peak output power specified on the nameplate. Otherwise, customers should reduce the load or configure a frequency converter.

## 1.2 Personnel Requirements

- Professionals or well-trained personnel must be assigned to install, operate, and maintain the equipment. During operations, irrelevant personnel are prohibited from approaching the work area.
  - Professionals: Personnel who are familiar with the composition and working principle of the system or equipment, have participated in training or operated the equipment, and are familiar with the factors that may lead to risks during the installation, operation, and maintenance of the equipment and risk levels.
  - Well-trained personnel: Personnel who have participated in relevant technical and safety training, have relevant experience, can identify operational risks, and can take relevant corrective measures to reduce the impact of risks.
- For special operations, such as climbing and electrical operations on high-voltage equipment, the operator must be certified for special operations as required by the local country/region.
- Only authorized professionals can replace the equipment or components (including software), remove safety devices, or repair the equipment.

# Chapter 2 Handling and Transportation Requirements

## 2.1 Routine Requirements

- Wear personal protective equipment such as protective gloves and safety shoes while handling the equipment.
- Select an appropriate handling method according to the equipment weight.
- When handling the equipment, always follow the package orientation marking. Do not turn the equipment upside down or tip it over.
- The tilt angle of the equipment with packaging must be less than or equal to 15°. After the equipment is unpacked, its tilt angle must be less than or equal to 10°. Take into account the heights of persons assigned to handle the equipment to ensure that the equipment is handled stably.
- Lift or move the equipment slowly to avoid personal injury.
- When using a forklift, position the forks so that the center of gravity of the equipment is aligned and secure the equipment as needed. Designate a person to keep an eye on the handling. Do not stand under the forks.
- Place the equipment according to the stack requirement indicated on the packaging.
- Ensure the equipment is placed on a flat and stable surface and do not tilt or place the equipment upside down.
- Transport the equipment with proper protective measures to avoid exposure to rain or water.

## 2.2 Battery Pack

### Caution

- Do not use the equipment if it has been dropped, subjected to mechanical shock, submerged in water, or otherwise exposed to water.
- If the equipment has been exposed to rain or snow, please have it evaluated by a professional before using it again.

### Tips

The equipment belongs to Class 9 Dangerous Goods and has been approved by UN38.3 (UN38.3: Section 38.3 of the sixth Revised Edition of the Recommendations on the Transport of Dangerous Goods: Section 38.3 of the sixth revised edition of the recommendations on the transport of dangerous goods: Manual of Tests and Criteria) and SN/T 0370.2-2009 "Inspection Procedures for Packaging of Dangerous Goods for Export Part 2: Performance Inspection".

### Loading and Unloading Requirements:

Load and unload the equipment according to local laws, regulations, and industry standards. Violent loading and unloading are prohibited. Handle the equipment with care; otherwise, it may break, leak, fire, or explode.

### Prior to Transportation:

- Before transportation, ensure that the package is intact and no odor, smoke, or fire occurs. Otherwise, do not transport the equipment.
- Before transportation, ensure that the equipment are securely placed and protected from moisture.
- It is forbidden to place the equipment in the same vehicle or container with common articles such as food, medicine and animal feed.
- If the equipment must be shipped with common goods, please take the following measures:
  - The space between common articles and equipment is  $\geq 0.8$  m.
  - Use isolators as high as the equipment package for isolation.
- Never arrange the equipment in the same vehicle or container with flammable, explosive or corrosive materials.

### During Transportation:

- Please comply with international regulations on the transport of dangerous goods and meet the requirements of the local transport regulatory authorities of the countries of shipment, route, and destination.
- It is prohibited to transport by rail and by air.
- For transport by sea, please observe the transport requirements of the International Maritime Dangerous Goods CODE (IMDG CODE).

- For land transport, please follow the requirements of the European Agreement Concerning the International Carriage of Dangerous Goods by Road (ADR) or the Regulations Concerning Road Transportation of Dangerous Goods (JT/T 617).
- It is recommended to transport by sea or choose a road with good road conditions, and minimize turbulence or tilt in the process of transport.

# Chapter 3 Storage Requirements

- The storage location must comply with local laws and regulations.
- Do not store the equipment without packaging. If the equipment has been unpacked and is not put into use immediately, please place it back into its original packaging with the desiccant retained and seal it with tape.
- Do not store battery packs with other items. Fire fighting facilities such as fire extinguishers that meet requirements must be placed at the battery pack storage site.
- Do not expose the equipment to direct sunlight or to wet, dewy, dirty, rainy, flammable, explosive or corrosive environments.
- Regularly check the equipment (recommended once every three months) during the storage period. Take measures to prevent pests and rodents in the storage area. Replace the packaging immediately if the packaging is damaged by pests or rodents.
- When storing the equipment, place it according to the storage requirements on the package.
- When temporarily storing equipment outdoors, stacking on pallets is prohibited, and protective measures (such as providing tarpaulins, etc.) must be implemented to prevent the equipment from being exposed to rain, snow, standing water, or other corrosive elements.
- During storage, periodically record the temperature and humidity of the storage environment.
  - Storage temperature: -25°C to 60°C, and 20°C to 30°C is recommended.
  - Relative humidity: 0% to 100% RH. Do not install the battery pack if the battery pack interface is moist and dewy.
- Before storing the battery pack, ensure that the capacity of the battery pack is 40%±5% SOC.
- If your equipment has been stored for more than 2 years, please go through professional inspection and testing before putting it into operation.
- When storing the battery pack, the warehouse manager needs to count and report the inventory status monthly. When the recharge period is approaching, please arrange to recharge in time.
- To ensure the inverter's optimal performance, if the period of non-operation after installation exceeds 6 months (or exceeds 3 months in an offshore environment), it must be inspected and tested by qualified personnel before being put into service.

Storage temperature requirement	Actual storage temperature	Recharge period
-25°C < T ≤ 60°C	T ≤ -25°C	Not allowed
-25°C < T ≤ 60°C	-25°C < T ≤ 25°C	15 months
-25°C < T ≤ 60°C	25°C < T ≤ 35°C	9 months
-25°C < T ≤ 60°C	35°C < T ≤ 60°C	6 months
-25°C < T ≤ 60°C	60°C < T	Not allowed

- The storage time of battery packs is calculated from the shipping time on the outer packaging. After the battery is properly charged, update the latest charging time (YYYY-MM-DD is recommended).
- It is not recommended to store battery packs beyond the recommended storage period. After first 12 months at the recommended storage temperature, the irreversible capacity loss is 3% to 10%. If

battery packs are stored beyond the expiration date, expiry date, they should be checked and tested by qualified personnel before use.

- Please follow the "first-in, first-out" principle when shipping the equipment.

# Chapter 4 Operation Requirements

## Danger

### High Voltage and Hazards:

- Do not perform operations on the equipment with power on (including but not limited to installation, wiring, replacement). Before operation, please make sure all power supplies to the equipment have been disconnected, including but not limited to the grid side, inverter and diesel generator power switches. Operation with power on may lead to fire, electric shock, arcing, or explosion, resulting in personal injury or property loss.
- When the inverter is connected to the grid, do not perform maintenance operations on the DC input cable, such as connecting or disconnecting a string or a component in the string. Otherwise, it may cause an electric shock or an arcing fire.
- Do not power on the equipment before the installation or professional evaluation is complete.
- Do not operate the equipment in bad weather conditions, including but not limited to lightning, rain, snow, or typhoon.
- Do not expose the equipment to high temperatures or heat sources for an extended period of time, such as sunlight, ignition sources, or heaters.
- Do not clean or soak the equipment with water, alcohol, oil, or other liquids to avoid leakage current and electrical shock.
- Do not impact, drag, or step on the equipment. In case of accidental impact, stop using the equipment immediately and contact your sales representative. The equipment shall be subject to inspection and evaluation by professionals before being put into operation again.
- Before operating the equipment, check whether the equipment is damaged. For any abnormality, such as appearance deformation or odor, contact your sales representative instead of disassembling the equipment without authorization.
- If you find that the equipment works abnormally or that the equipment may cause personal injury, such as appearance deformation, odor, or arcing, stop your operation immediately, report the fact to the person in charge, and take effective measures.
- Wear personal protective equipment such as insulating gloves, insulating shoes, and safety hats while operating the equipment. Do not wear conductive accessories such as metal bracelets, rings, or necklaces.
- Use insulated tools when installing or wiring.
- Equipment that must be grounded is permanently connected to the PGND. Connect the PGND in the first step before connecting cables, and when replacing an equipment, remove the PGND in the last step.
- Do not touch terminals with bare hands or conductors or damp objects. Measure the voltage of the contact before touching a terminal to avoid the risk of electric shock.
- Prevent foreign objects from falling into the equipment while operating the equipment. Otherwise, the equipment may be short-circuited or damaged, or power supply to loads may be derated or power failure may occur, or this may even result in personal injury.
- Touch up paint scratches on the surface of the equipment.

## Safety Requirements

### Danger

- It is prohibited to expose the equipment to high-temperature environments for a long time or keep heat sources (such as sunlight, fire sources, heaters, etc.) around the equipment for an extended period.
- It is prohibited to clean or soak the equipment with water, alcohol, oil, etc., to prevent electrical leakage or other issues.
- It is prohibited to strike or impact the equipment. In case of accidental impact, stop using the equipment immediately and contact your installer or sales agent promptly. The equipment can only be reused after being inspected and evaluated by professionals.

### Warning

- Do not disable any protective devices, including but not limited to protective covers and surge arresters.
- Do not touch the hot surface in the heat dissipation area when the equipment is operating.
- Do not cover the heat dissipation area, and maintain a 300 mm to 600 mm channel for heat dissipation to prevent high temperatures from causing a fire when the equipment is operating.

### Caution

- You must obtain a license for power utilities in the country or region where the equipment is located before the equipment can be connected to the grid.
- Do not use damaged or unqualified cables or tools. Before operating the equipment, ensure that all cables and tools comply with the requirements, and keep records. Upon completion of operation, make an inventory and recover the cables and tools in full to prevent them from being left in the equipment to avoid safety hazards.
- Comply with the power station safety regulations of the country or region where the equipment is located when operating the equipment, including but not limited to operation tickets and work tickets.
- Carbon dioxide fire extinguishers or ABC dry powder fire extinguishers are recommended.
- Keep irrelevant personnel away from the operation site. Please install a temporary fence or set a warning line around the operation site, and attach "No Entry for Irrelevant Personnel" and other signs.
- Do not cover or damage the warning label or nameplate on the equipment. Replace the warning label or nameplate if it is damaged or cannot be clearly recognized due to long-term use.
- Before operating or maintaining the equipment, check whether there is water, snow, or other debris on the top of the equipment. Clean it up when necessary.

### Do not use the equipment in the following situations:

- When connected to public infrastructure systems, such as traffic lights or security systems.
- When connected to emergency medical equipment.

- When connected to elevators and other control devices.
- Any other critical systems.

## 4.1 Equipment Installation

### Warning

- Before installing the equipment, check whether the screws installed before delivery are secured. Before delivery, the tightened screws are marked with lines. If the marks are misaligned, the screws are loose. Tighten the screws again.

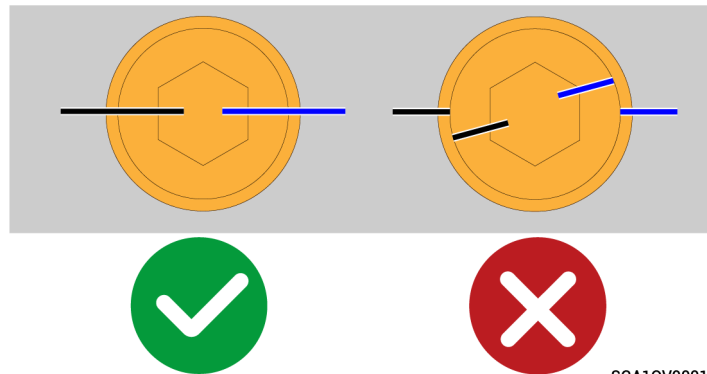

SGA10V00019

- Get well prepared for the bearing load when handling the equipment to prevent it from falling and causing injury.

### Ladder Safety

- Do not use ladders if you are not well-trained or instructed.
- Do not use unqualified ladders, including but not limited to damaged, broken, deformed, or temporary ladders.
- Do not use a ladder that does not meet the load-bearing requirements.
- Use wooden or fiberglass ladders when you climb up for electrical operations.
- A straight ladder must be set at a gradient of 60° to 70°.
- Do not throw objects from heights when operating on a ladder.
- We recommend that you designate a person to monitor when operating on a ladder.
- Lock the door when using a ladder at the entrance of the passageway.

### Lifting safety

- Personnel performing lifting operations must undergo relevant training and be qualified before they can take up their posts.
- Temporary warning signs or fences must be erected in the lifting area for isolation.
- The foundation for lifting operations must meet the load-bearing requirements of the crane.
- Before lifting, ensure that the lifting tools are firmly fixed to a fixed object or wall that meets the load-bearing standards.

- During lifting, it is strictly forbidden to walk under the boom or the lifting object.
- During lifting, do not drag the wire rope or lifting equipment, and do not use hard objects to hit.
- During the lifting process, ensure that the angle between the two slings is no greater than  $90^\circ$ , as shown in the figure below.

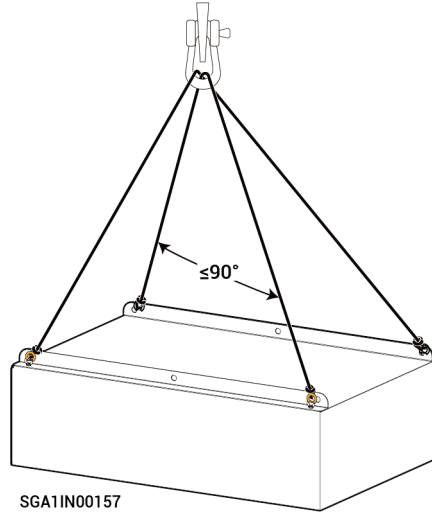

SGA1IN00157

## Drilling Safety

- Do not drill holes on the equipment.
- Wear safety goggles and protective gloves when drilling holes.
- Do not place the equipment near drilling positions to prevent debris from falling into the equipment.
- Clean up any debris promptly after drilling.

## 4.2 Cable Connections

### Danger

- Before connecting cables, ensure that the equipment is not damaged. Otherwise, electric shock or fire hazard may occur.
- Before connecting or removing cables, ensure that the upstream and downstream switches of the equipment and the switches on the equipment are turned off.

- Do not intertwine cables or route cables across each other. It is recommended that cables be bundled by category. If you find that the power cord length is not sufficient, you must replace the power cord. It is strictly forbidden to make joints or soldering points in the power cord.
- The cables must be vertically inserted into the equipment to avoid the terminals being damaged due to lateral force.
- Do not route cables through the air inlet and air outlet of the equipment.
- Do not use cables with damaged insulation. No sharp edges or burrs are allowed in cable holes. Replace cables with insufficient length. Do not extend cables using welding or similar methods.
- The ground impedance of the equipment should meet national and regional standards.
- Verify the cable selection by referring to IEC-60364-5-52 or local laws and regulations if there are changes in cabling methods or environmental conditions such as temperature and humidity.
- Keep cables at least 100 mm away from the heat source to prevent cable aging at high temperatures.
- The lower the ambient temperature is, the more brittle the cable plastic sheath becomes. To prevent sheath cracking during installation, install cables at temperatures above 0°C and handle them with caution when transporting. If cables have been stored in an environment below 0°C for an extended period of time, move cables to an environment above 0°C for at least 24 hours before using again.
- Before installing cables, ensure that cables are properly labeled, insulated, and identified. Connect cables correctly and completely according to the labels and installation instructions.
- For underground cabling, fix cables with cable trays and clips. Before backfilling, reserve a proper cable length to ensure that cables are tightly fitted against the ground in the backfilling area. Otherwise, terminals may be deformed, damaged, or loosened due to stress on cables.
- When installing the equipment, a torque tool with a suitable range should be used to tighten the screws. When tightening with a wrench, ensure that the wrench is not skewed, and the torque value error does not exceed the specified 10%.

## 4.3 Safety Tips for Working at Heights

- Comply with the local regulations on working at heights.
- Operators engaged in working at heights shall behave in strict accordance with the safety regulations on working at heights, and the Company shall not be liable for accidents caused by the violation of the safety regulations on working at heights.
- Carrying out work at more than 2 meters above the ground is considered as work at heights.
- Do not work at heights in one of the following conditions: steel pipe not drying up and other conditions that may cause danger.
- Before working at heights, carefully check the climbing tools and safety appliances, such as safety hats, safety belts, ladders, platforms, scaffolds, and lifting equipment, and take immediate improvement measures or refuse to work at heights if any requirements are not met.
- Mark out a hazardous area on the work-at-height scene and set an eye-catching sign indicating that unauthorized personnel are prohibited from entering.
- Set guardrails and signs at the edges and holes in the work-at-height area to prevent accidental falls.
- It is strictly forbidden to stack scaffolds, platforms, or other things on the ground below the work-at-height area. Personnel on the ground should be strictly prohibited from staying or passing through directly below the work-at-height area.
- Try to avoid working on the upper and lower platforms at the same time. If this cannot be avoided, a special catch platform should be set, or other protective measures should be taken between the upper and lower platforms. It is strictly forbidden to stack tools, materials, and other things on the upper platform.
- Take protection measures, wear a safety hat and a safety belt or a waist rope, tie it to a solid and rigid structural member. It is strictly forbidden to hang it on an unstable moving object or metal with sharp corners to prevent accidental falls due to hook slip.
- Carry the operating apparatuses and tools well and prevent them from falling and injuring others.
- Workers at heights are strictly forbidden from throwing objects from heights to the ground nor from the ground to heights. Rigid ropes, hoists, aerial lifts, or cranes should be used to transport objects.
- Horseplay is strictly forbidden while working at heights, and resting in the work-at-height area is prohibited.
- After work at heights, climbing tools, safety appliances, personal protective equipment, and other things shall be cleaned up or taken away from the scene, and the scene shall be restored to its original state.

## 4.4 Equipment Maintenance and Replacement

- Before maintaining or replacing the equipment, power off and wait for the delay time as instructed on the label on the equipment before operation.
- When maintaining the power equipment or power distribution equipment at the downstream direction of the power supply equipment, turn off the output switch of the power supply equipment.
- When maintaining the power distribution equipment or power equipment at the downstream direction of the power supply equipment, turn off the output switch of the power supply equipment. To maintain a load, disconnect the load from the power switch.
- During equipment maintenance, attach labels, for example, "Do Not Turn On", on the upstream and downstream switches or circuit breakers and set warning signs to prevent accidental reconnection. Power up and put the equipment back into operation only after trouble is eliminated, or replacement is complete.
- Damaged cables, if any, should be replaced by professionals.

# Chapter 5 Introduction to energy storage system

## 5.1 Product Introduction

### 5.1.1 Sigen Inverter

#### Sigen PV (50–166)M1

PV inverter, suitable for PV scenarios, must be used with PV modules.

Model No.	Name
Sigen PV 50M1	Sigen PV Inverter 50 kW M1 Version
Sigen PV 60M1	Sigen PV Inverter 60 kW M1 Version
Sigen PV 80M1	Sigen PV Inverter 80 kW M1 Version
Sigen PV 100M1	Sigen PV Inverter 100 kW M1 Version
Sigen PV 110M1	Sigen PV Inverter 110 kW M1 Version
Sigen PV 125M1	Sigen PV Inverter 125 kW M1 Version
Sigen PV 150M1	Sigen PV Inverter 150 kW M1 Version
Sigen PV 166M1	Sigen PV Inverter 166 kW M1 Version
Sigen PV 50M1-AU	Sigen PV Inverter 50 kW M1 Version Australia
Sigen PV 99.9M1-AU	Sigen PV Inverter 99.9 kW M1 Version Australia
Sigen PV 110M1-AU	Sigen PV Inverter 110 kW M1 Version Australia
Sigen PV 125M1-AU	Sigen PV Inverter 125 kW M1 Version Australia

#### Sigen PV (150–166)M2

Model No.	Name
Sigen PV 150M2	Sigen PV Inverter 150 kW M2 Version
Sigen PV 166M2	Sigen PV Inverter 166 kW M12 Version

#### Sigen PV (50–125)M1-HYA

On-grid hybrid inverter, suitable for on-grid PV storage scenarios, must be used with PV modules and SigenStack.

Model No.	Name
Sigen PV 50M1-HYA	Sigen Hybrid Inverter 50 kW M1 Version
Sigen PV 60M1-HYA	Sigen Hybrid Inverter 60 kW M1 Version

Model No.	Name
Sigen PV 80M1-HYA	Sigen Hybrid Inverter 80 kW M1 Version
Sigen PV 100M1-HYA	Sigen Hybrid Inverter 100 kW M1 Version
Sigen PV 110M1-HYA	Sigen Hybrid Inverter 110 kW M1 Version
Sigen PV 125M1-HYA	Sigen Hybrid Inverter 125 kW M1 Version
Sigen PV 50M1-HYA-AU	Sigen Hybrid Inverter 50 kW M1 Version Australia
Sigen PV 99.9M1-HYA-AU	Sigen Hybrid Inverter 100 kW M1 Version Australia
Sigen PV 110M1-HYA-AU	Sigen Hybrid Inverter 110 kW M1 Version Australia
Sigen PV 125M1-HYA-AU	Sigen Hybrid Inverter 125 kW M1 Version Australia

## Sigen PV (50–110)M1-HYB

Off-grid and on-grid hybrid inverter, suitable for off-grid and on-grid PV storage scenarios, must be used with PV modules and SigenStack.

Model No.	Name
Sigen PV 50M1-HYB	Sigen Hybrid Inverter 50 kW M1 Version With Backup Port
Sigen PV 60M1-HYB	Sigen Hybrid Inverter 60 kW M1 Version With Backup Port
Sigen PV 80M1-HYB	Sigen Hybrid Inverter 80 kW M1 Version With Backup Port
Sigen PV 100M1-HYB	Sigen Hybrid Inverter 100 kW M1 Version With Backup Port
Sigen PV 110M1-HYB	Sigen Hybrid Inverter 110 kW M1 Version With Backup Port
Sigen PV 50M1-HYB-AU	Sigen Hybrid Inverter 50 kW M1 Version With Backup Port
Sigen PV 99.9M1-HYB-AU	Sigen Hybrid Inverter 100 kW M1 Version With Backup Port
Sigen PV 110M1-HYB-AU	Sigen Hybrid Inverter 110 kW M1 Version With Backup Port
Sigen PV 100M1-HYB-JP	Sigen Hybrid Inverter 110 kW M1 Version Without Backup Port

## 5.1.2 SigenStack Energy Storage System

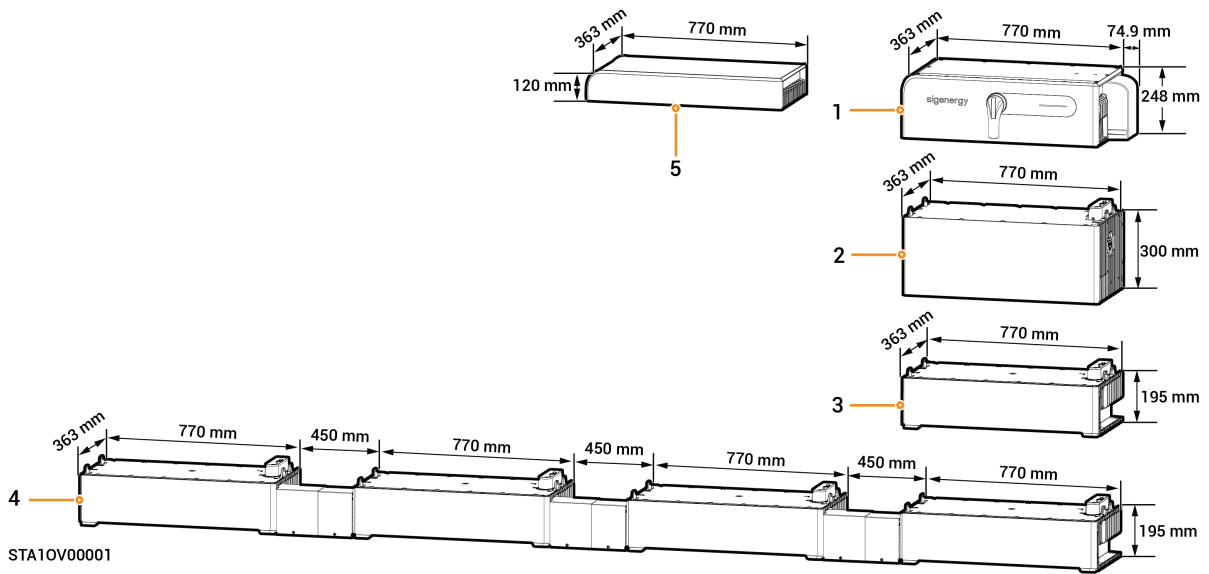

No.	Model	Description	Abbreviated Form
1	SigenStack BC M2-1C-BST	Battery controller (including DC-DC boost converter module).	BC-BST
	SigenStack BC M2-0.5C-BST		
	SigenStack BC M2-0.5C	Battery controller.	BC
2	SigenStack BAT 12.0	Energy storage battery.	BAT
3	SigenStack Base MAIN-0.5C	Main base, for the Main stack containing the battery controller.	Base MAIN
	SigenStack Base MAIN-1C		
	SigenStack Base SUB-0.5C	Sub-base, for the Sub stack containing the energy storage battery top cover.	Base SUB
	SigenStack Base SUB-1C		
4	SigenStack Base 4S-0.5C	Quadruple base, including one main base and three sub-bases.	Base 4S
5	SigenStack Cover	Energy storage battery top cover, for the Sub stack containing the sub-base.	Cover

### 5.1.3 Sigen Power Sensor

Equipped with grid connection point data collection to achieve zero-power grid connection functionality.

Product code	Model No.	Name
Power Sensor	Sigen Sensor TP-CT300-DH (SDM630MCT 40mA/300A)	Sigen Power Sensor Three Phase External CT 300 A DH
Power Sensor	Sigen Sensor TP-CT600-DH (SDM630MCT V2/600A)	Sigen Power Sensor Three Phase External CT 600 A DH
Power Sensor	Sigen Sensor TPX-CH (DTSU666)	Sigen Power Sensor Three Phase Without CT CH

## 5.1.4 Sigen Communication Module

If it's used with our inverters, the communication between inverters and management systems should be realized through 4G.

Product code	Model No.	Name
Sigen CommMod	Sigen CommMod	Sigen Communication Module

## 5.1.5 Sigen Communication Bridge

When used with our company's C&I inverters or gateways, the communication distance on the inverter or gateway side can be extended to 800 meters.

Product code	Model No.	Name
Sigen CommBridge	Sigen CommBridge	Sigen Communication Bridge

## 5.2 Appearance Introduction

### 5.2.1 Sigen PV (50–125)M1 Inverter

#### Dimensions

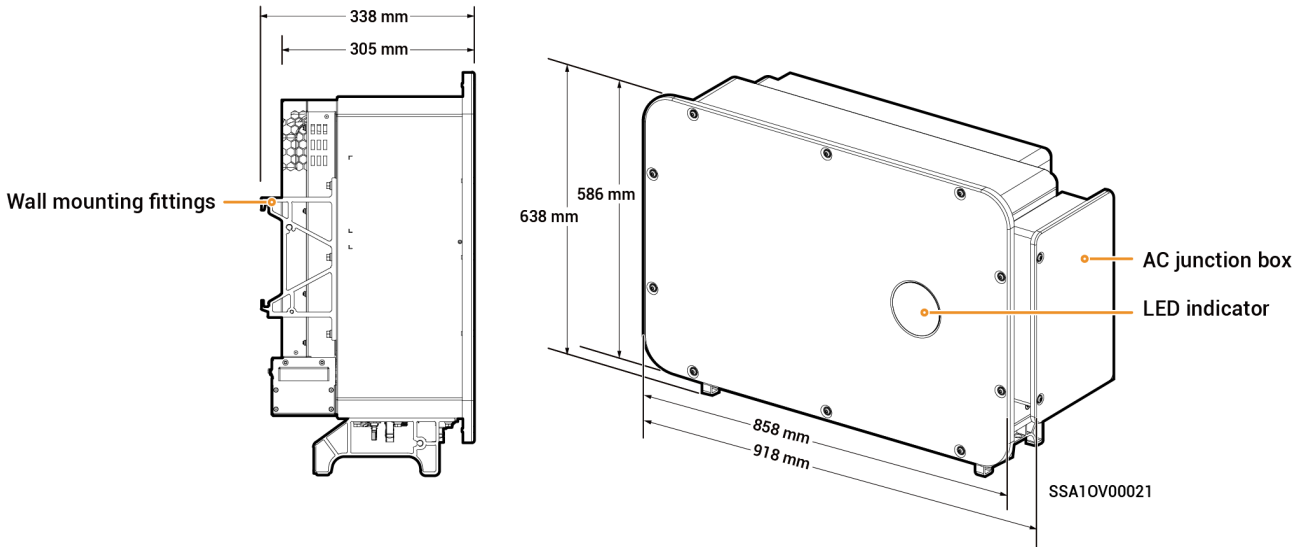

#### Port Descriptions

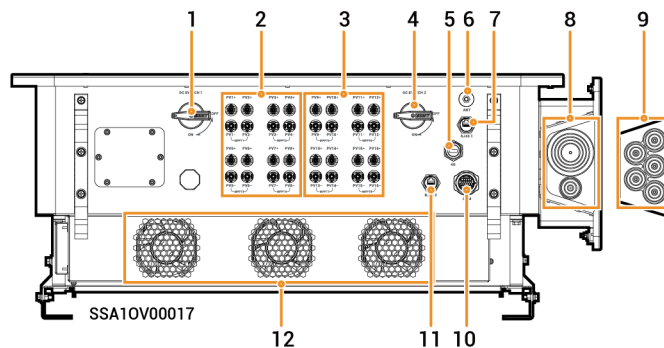

S/N	Name	Marking
1	DC switch 1	DC SWITCH 1
2	DC input terminal group 1 (Controlled by DC SWITCH 1)	PV1 to PV8
3	DC input terminal group 2 (Controlled by DC SWITCH 2)	PV9 to PV16
4	DC switch 2	DC SWITCH 2
5	Sigen CommMod interface	4G
6	Antenna interface	ANT
7	Network interface	RJ45 1
8	Routing hole for multi-core cable	-

S/N	Name	Marking
9	Routing hole for single-core cable	-
10	Communication interface	COM
11	Network interface	RJ45 2
12	Cooling fan	-

## 5.2.2 Sigen PV (50–110)M1-HYA Inverter

### Dimensions

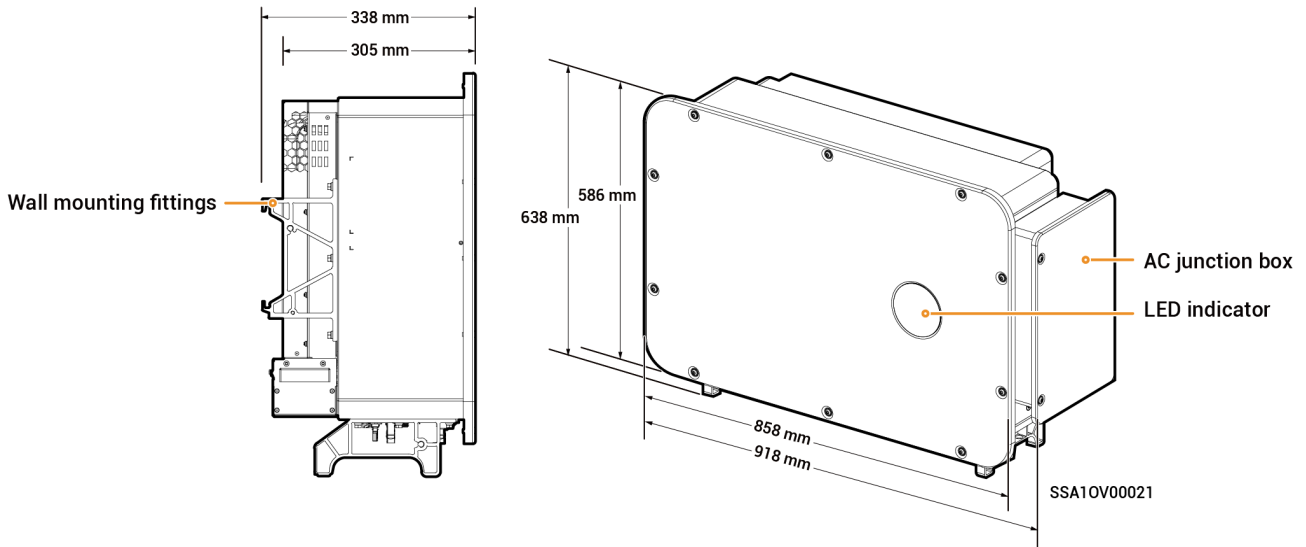

### Port Descriptions

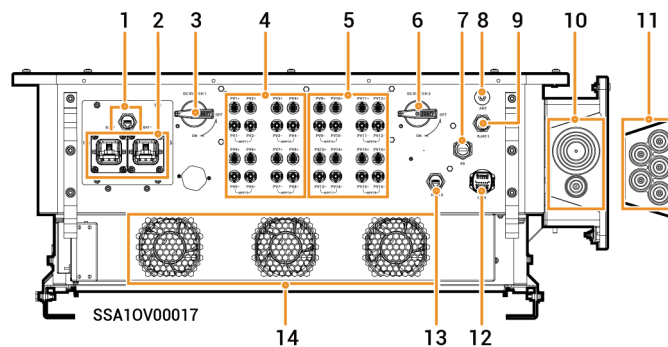

S/N	Name	Marking
1	SigenStack network interface	RJ45 3
2	SigenStack DC cable interface	BAT+/BAT-
3	DC switch 1	DC SWITCH 1
4	DC input terminal group 1 (Controlled by DC SWITCH 1)	PV1 to PV8
5	DC input terminal group 2 (Controlled by DC SWITCH 2)	PV9 to PV16
6	DC switch 2	DC SWITCH 2
7	Sigen CommMod interface	4G
8	Antenna interface	ANT
9	Network interface	RJ45 1
10	Routing hole for multi-core cable	-

S/N	Name	Marking
11	Routing hole for single-core cable	-
12	Communication interface	COM
13	Network interface	RJ45 2
14	Cooling fan	-

## 5.2.3 Sigen PV 125M1-HYA Inverter

### Dimensions

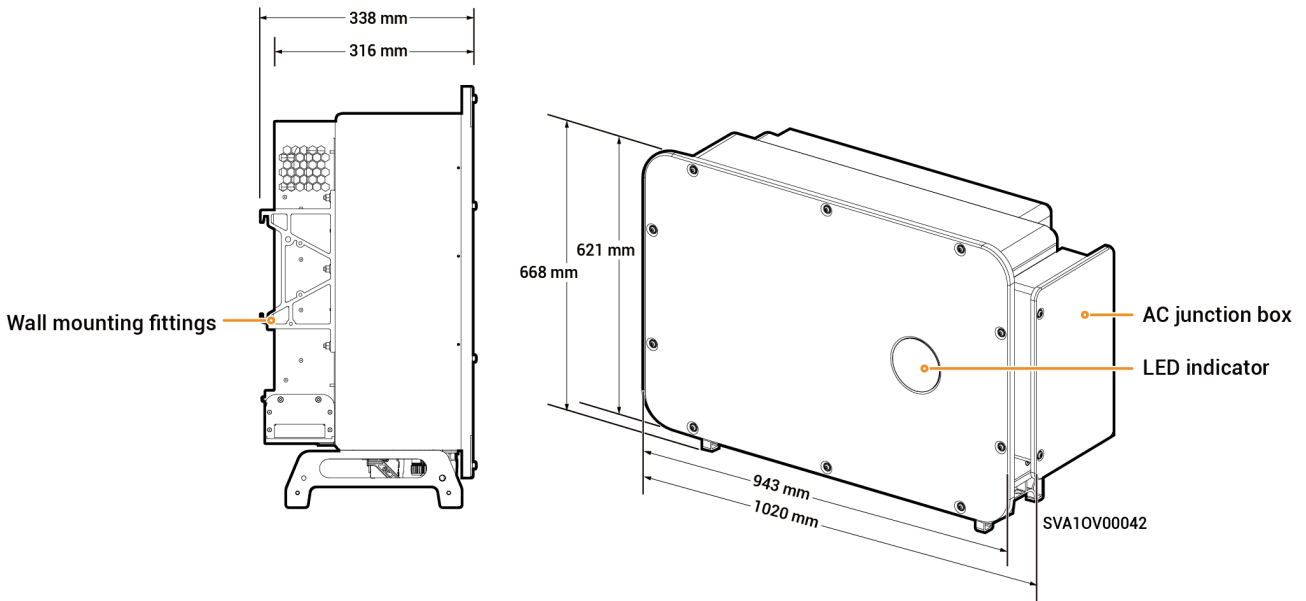

### Port Descriptions

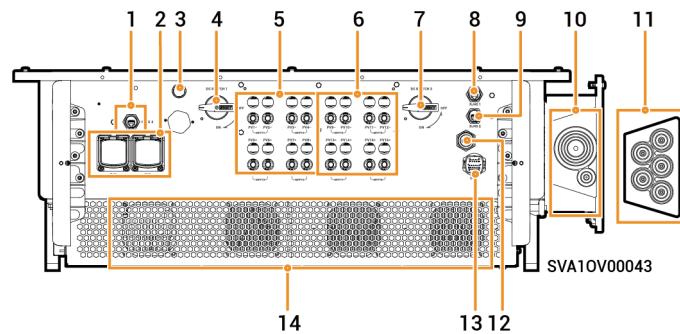

Serial Number	Name	Silkscreen
1	SigenStack Ethernet Port	RJ45 3
2	SigenStack DC Cable Interface	BAT+/BAT-
3	Antenna interface	ANT
4	DC switch 1	DC SWITCH 1
5	DC input terminal group 1 (controlled by DC SWITCH1)	PV1 ~ PV8
6	DC input terminal group 2 (controlled by DC SWITCH2)	PV9 ~PV16
7	DC switch 2	DC SWITCH 2
8	Ethernet port	RJ45 1
9	Ethernet port	RJ45 2

Serial Number	Name	Silkscreen
10	(Optional)Backup load AC output wire routing hole	-
11	Grid AC output wire routing hole	-
12	Sigen CommMod interface	4G
13	Communication interface	COM
14	Cooling fan	-

## 5.2.4 Sigen PV (50–110)M1-HYB Inverter

### Dimensions

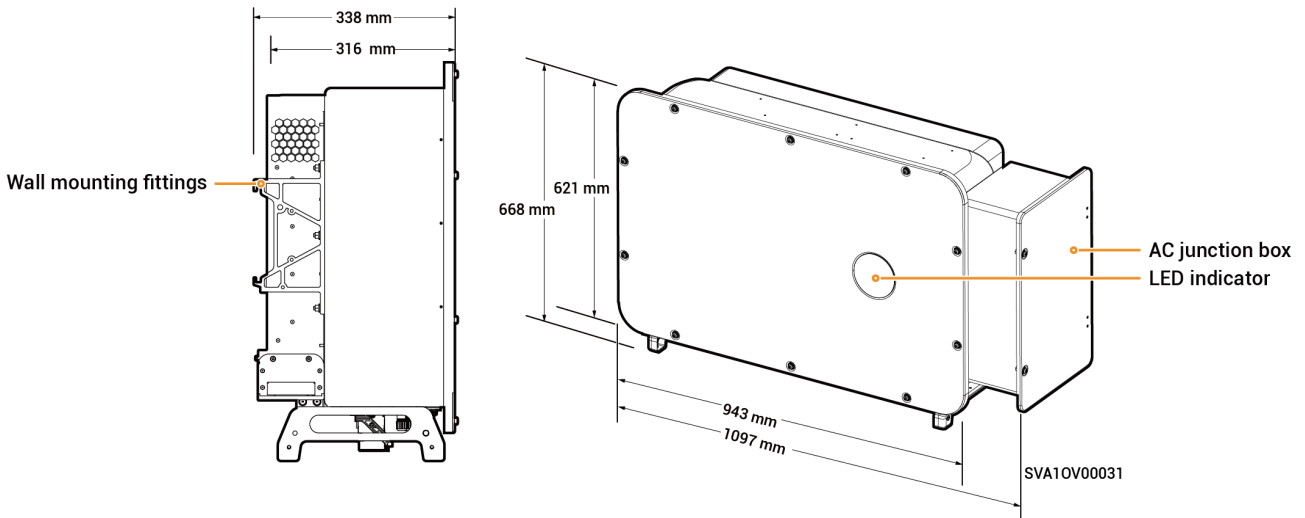

### Port Descriptions

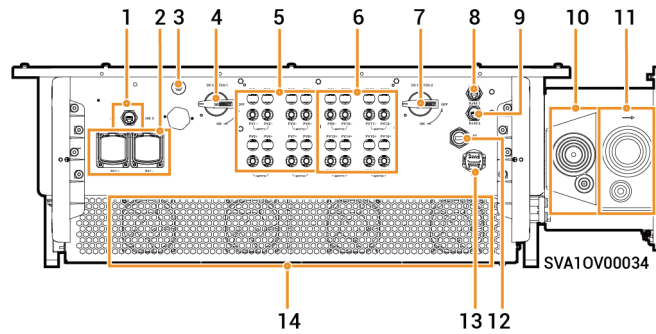

S/N	Name	Marking
1	SigenStack network interface	RJ45 3
2	SigenStack DC cable interface	BAT+/BAT-
3	Antenna interface	ANT
4	DC switch 1	DC SWITCH 1
5	DC input terminal group 1 (Controlled by DC SWITCH 1)	PV1 to PV8
6	DC input terminal group 2 (Controlled by DC SWITCH 2)	PV9 to PV16
7	DC switch 2	DC SWITCH 2
8	Network interface	RJ45 1
9	Network interface	RJ45 2
10	Wire-in port of backup loads	-
11	Wire-in port of power grid	-

S/N	Name	Marking
12	Sigen CommMod interface	4G
13	Communication interface	COM
14	Cooling fan	-

## 5.2.5 Sigen PV 100M1-HYB-JP

### Dimensions

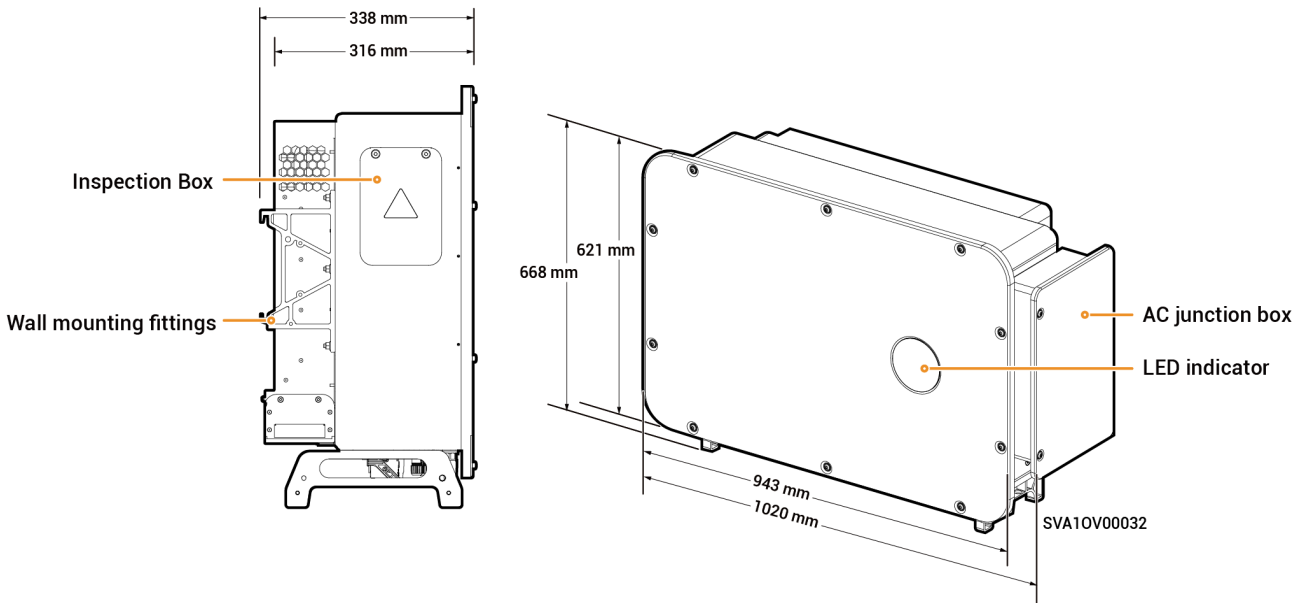

### Port Descriptions

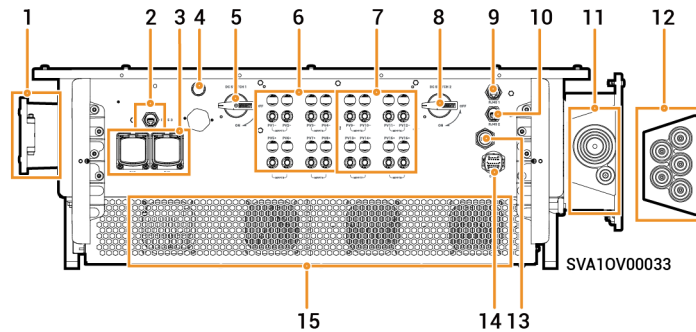

S/N	Name	Marking
1	Inspection Box	-
2	SigenStack network interface	RJ45 3
3	SigenStack DC cable interface	BAT+/BAT-
4	Antenna interface	ANT
5	DC switch 1	DC SWITCH 1
6	DC input terminal group 1 (Controlled by DC SWITCH 1)	PV1 to PV8
7	DC input terminal group 2 (Controlled by DC SWITCH 2)	PV9 to PV16
8	DC switch 2	DC SWITCH 2
9	Network interface	RJ45 1

S/N	Name	Marking
10	Network interface	RJ45 2
11	Wire-in port of backup loads	-
12	Wire-in port of power grid	-
13	Sigen CommMod interface	4G
14	Communication interface	COM
15	Cooling fan	-

## 5.2.6 Sigen PV (150–166)M1,(150–166)M2 Inverter

### Dimensions

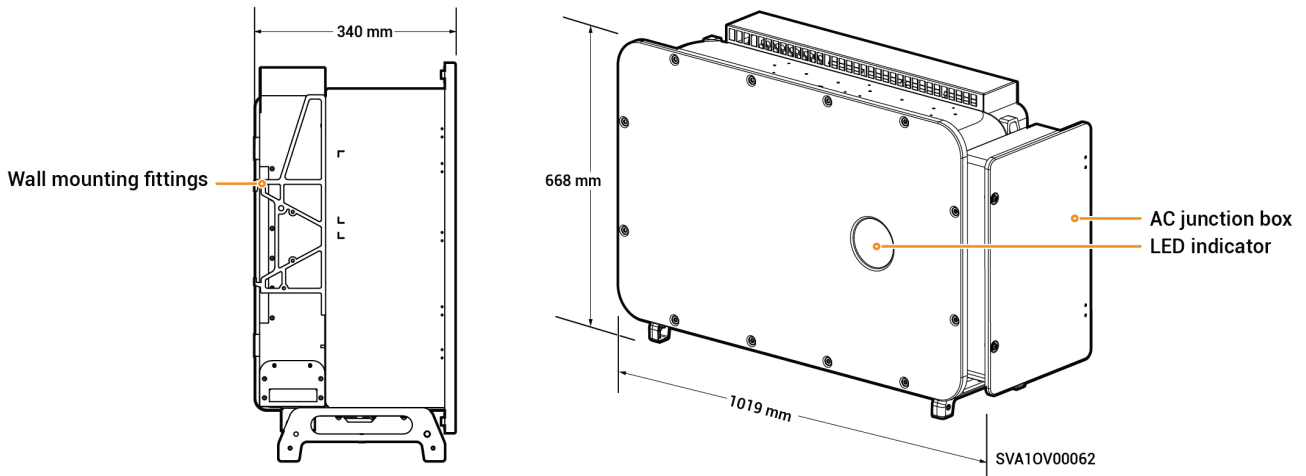

### Port Descriptions

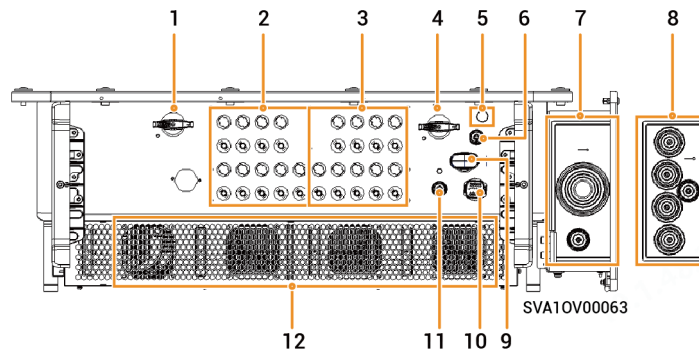

S/N	Name	Marking
1	DC switch 1	DC SWITCH 1
2	DC input terminal group 1 (Controlled by DC SWITCH 1)	PV1 to PV9
3	DC input terminal group 2 (Controlled by DC SWITCH 2)	PV9 to PV18
4	DC switch 2	DC SWITCH 2
5	Antenna interface	ANT
6	Network interface	RJ45 1
7	Routing hole for multi-core cable	-
8	Routing hole for single-core cable	-
9	Sigen CommMod interface	4G
10	Communication interface	COM
11	Network interface	RJ45 2

S/N	Name	Marking
12	Cooling fan	-

## 5.2.7 SigenStack Energy Storage System

### SigenStack BC M2-0.5C/0.5C-BST/1C-BST Ports and Switch Descriptions

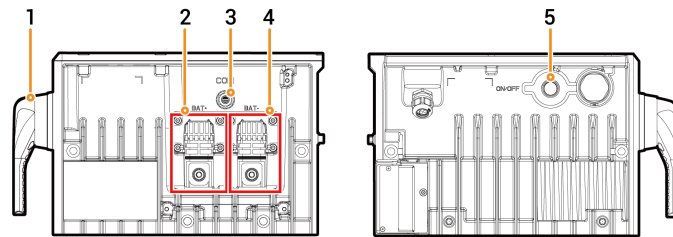

STA10V00004

S/N	Name	Marking
1	Disconnecting switch	-
2	Communication port	COM
3	Power port	BAT+/BAT-
4	Power button	ON/OFF

## 5.2.8 Sigen Communication Bridge

### Dimensions

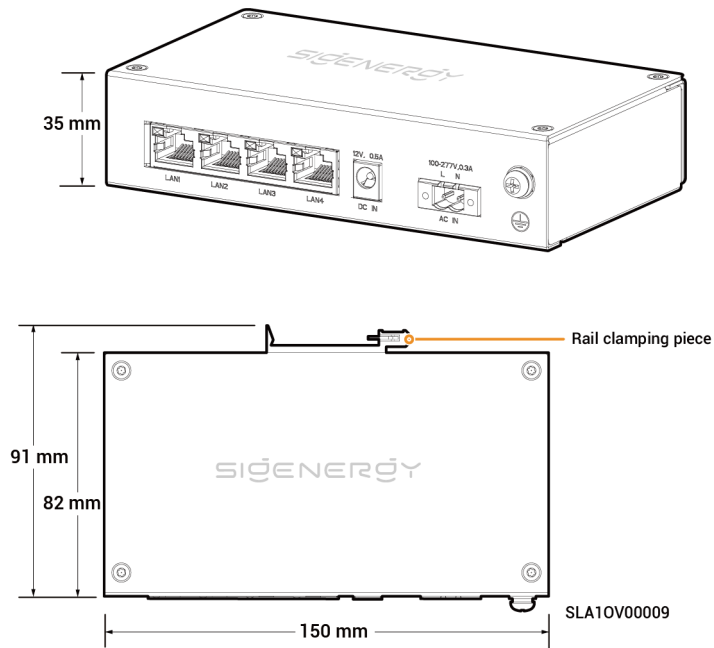



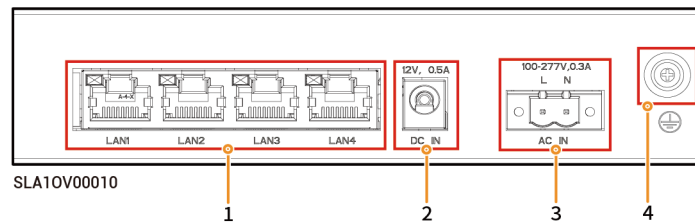



### Port Descriptions



S/N	Name	Marking
1	LAN interface	LAN1/LAN2/LAN3/LAN4
2	12V DC power input port	DC IN 12V, 0.5A
3	220V AC power input port	AC IN 100-277V, 0.3A
4	Protective grounding point	-

## 5.3 Label Description

Symbols	Definition
	<b>Danger! High Voltage</b> High voltage exists inside the equipment when powered on. Do not open the casing when the equipment is running. Any maintenance or servicing operations must be performed by trained and skilled electrical engineers.
	<b>Warning! Life-threatening</b> High contact current exists upon power-on. Ensure that the equipment is properly grounded before power-on. Potential risks exist when the equipment is operating. Please take protective measures before operating the equipment.
	After the equipment is powered off, the discharge of internal components is delayed. Wait 20 minutes until the equipment is fully discharged according to the label time.
	<b>Warning! Risk of burns.</b> The surface of the heat dissipation area is hot when the equipment is running. Do not touch it to avoid burns.
	The surface of the heat dissipation area is hot when the equipment is running. Do not touch it to avoid burns.
	Earthing mark

## 5.4 Supported Power Supply Methods for the Power Grid

- The grid supply methods supported include TN-S, TN-C, TN-C-S, TT and IT.
- When TT is used as the power supply technique for the power grid, the voltage between N and PE is required to be  $< 30$  V.

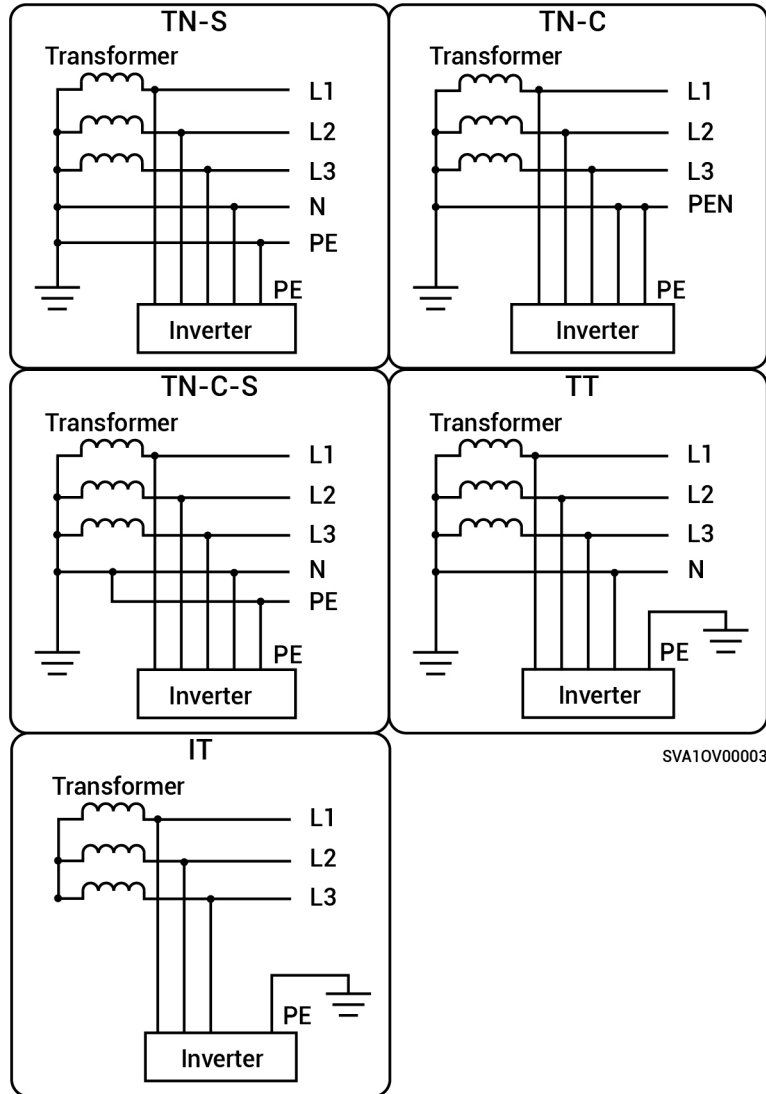

## 5.5 System wiring introduction

- Our products can be used in C&I on-grid solar systems. The on-grid solar system consists of PV strings, inverters, distribution panels, and other components.
- C&I PV storage systems primarily store direct current generated by PV panels in battery packs. They can also convert power from both PV panels and battery packs into alternating current to supply loads or feed into the grid.
- In off-grid solar systems, the inverter must handle the entire load power. While inverters possess short-term overload capability to meet transient overload demands (for example, motor starting), exceeding these limits triggers a protective shutdown. Additionally, high ambient temperatures cause inverter power derating. If the derated output power persistently falls below load requirements, this will also activate protective shutdowns.
  - System Design Suggestions:
    - a. Overload Matching: Ensure load starting power/duration remains below the inverter's short-term overload capability.
    - b. Power Rating Adaptation: Continuous load operating power must be lower than the inverter's actual output power under extreme ambient temperatures.
    - c. Environmental Compensation: Account for power derating effects from altitude and solar irradiance; provide sufficient design margin.

## Non-backup wiring diagram (number of inverters < 100)

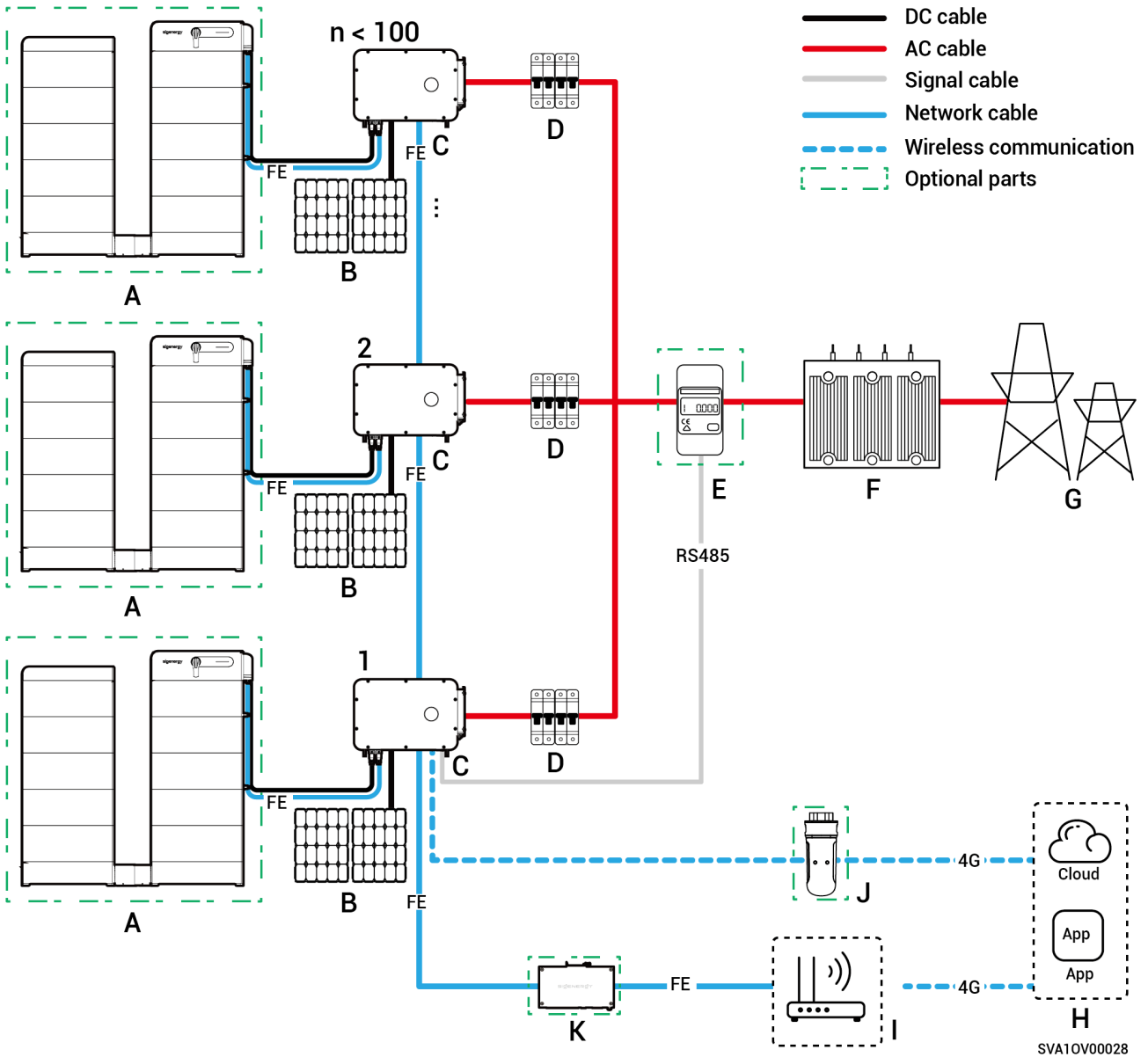

A. Battery	B. PV panel	C. Inverter	D. AC Switch (Depends on inverter power)	E. Power sensor
F. Box-type substation	G. Power grid	H. mySigen	I. Router	J. CommMod
K. CommBridge				

### Tips

- Each inverter must be equipped with an AC switch, and multiple inverters cannot be connected to one AC switch at the same time.

## Tips

- The rated voltage of the AC switch(D) connected to each inverter must be  $\geq 500$  Va.c., The recommended specifications for the rated current are as follows:
  - For inverters with a power rating of 50 kW or 60 kW: rated current is 125 A
  - For inverters with a power rating of 75 kW or 80 kW: rated current is 160 A
  - For inverters with a power rating of 99.9 kW or 100 kW: rated current is 200 A
  - For inverters with a power rating of 110 kW or 125 kW: rated current is 250 A
- It is recommended to use Fast Ethernet and WLAN for communication with inverters. When free 4G traffic of CommMod(J) runs out, users must replace a SIM card.

## Backup Power Networking Diagram (When HYB model is configure with an external Gateway, Inverters $\leq 50$ units)

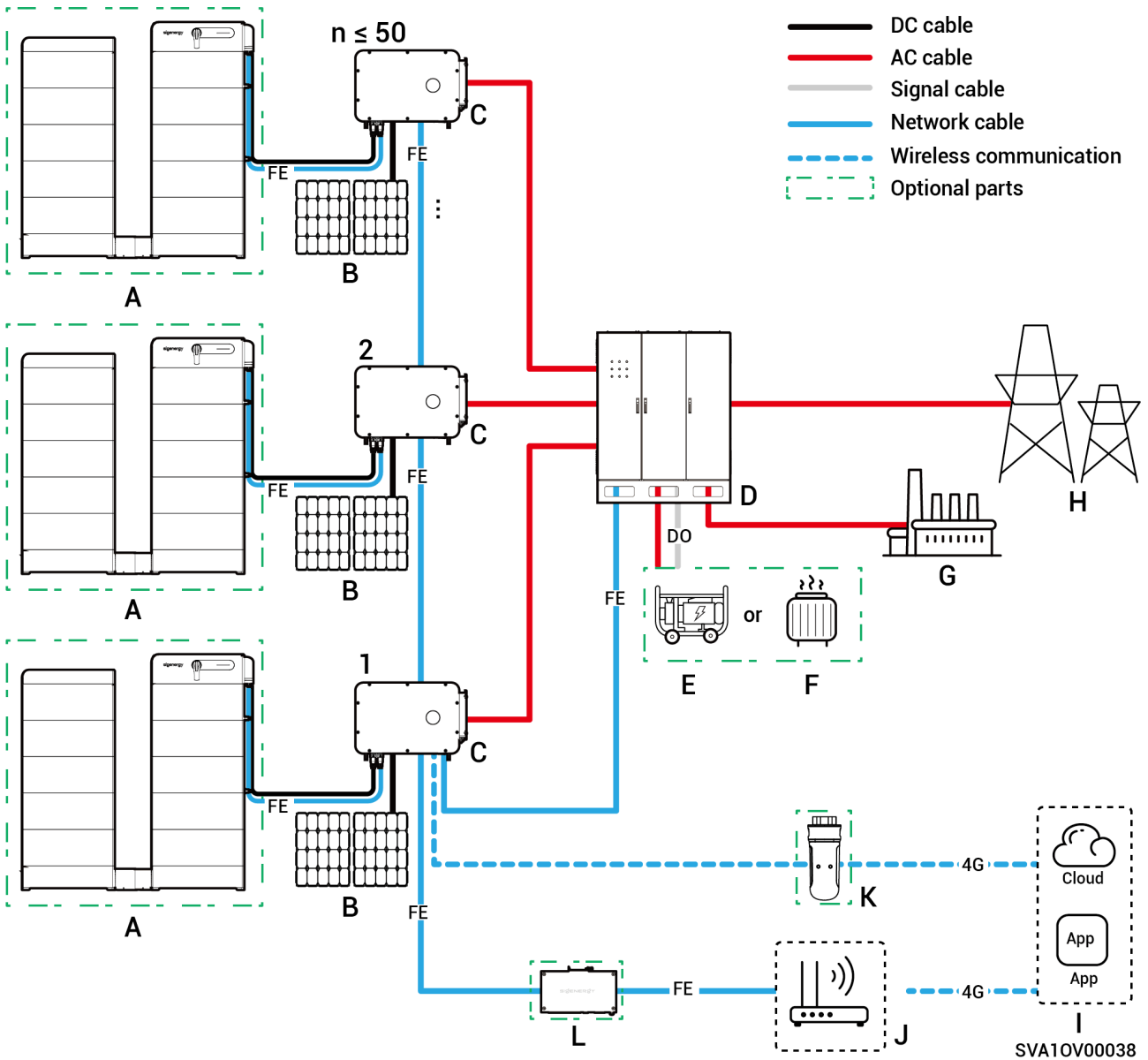

A. Battery	B. PV panel	C. Inverter	D. Gateway	E. Generator
F. Smart load	G. Backup load	H. Power grid	I. mySigen	J. Router
K. CommMod	L. CommBridge			

## Tips

- As a backup energy source for long-term off-grid applications, the generator (E) can work in tandem with the Gateway (D) to provide a smooth transition between PV, storage and diesel generation.
- It is recommended to use Fast Ethernet and WLAN for communication with inverters. When free 4G traffic of CommMod(K) runs out, users must replace an SIM card.

## Backup wiring diagram (When HYB model is configure with an internal Gateway, ≤ 3 Units)

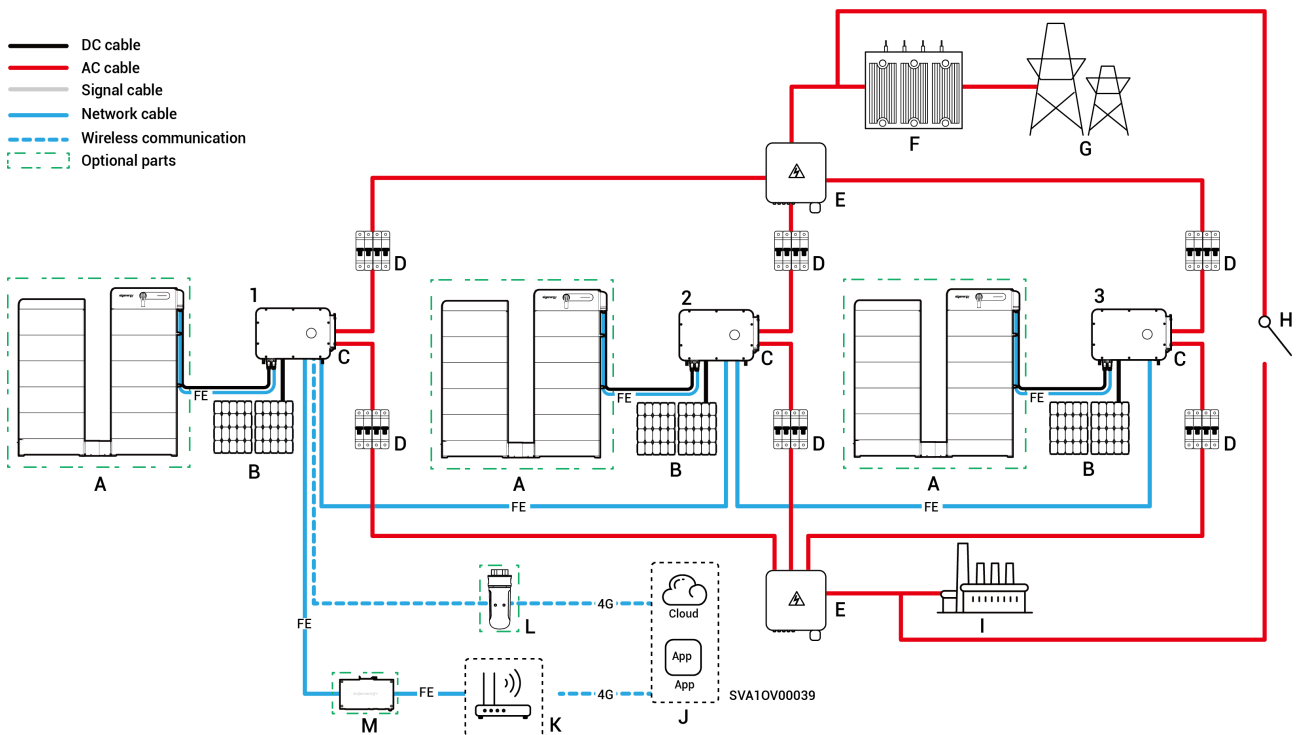

A. Battery	B. PV panel	C. Inverter	D. AC Switch (Depends on inverter power)	E. Combiner panel
F. Box-type substation	G. Power grid	H. Manual control switch	I. Backup load	J. mySigen
K. Router	L. CommMod	M. CommBridge		

## Tips

- Multiple inverters cannot be connected to one AC switch at the same time.

## Tips

- Every inverter connected to the backup load must use an AC switch (D) with a rated voltage of  $\geq 500\text{V}$  a.c. The recommended rated current specifications are as follows:
  - For inverters with a power rating of 50 kW: rated current is 100 A
  - For inverters with a power rating of 60 kW: rated current is 125 A
  - For inverters with a power rating of 80 kW: rated current is 160 A
  - For inverters with a power rating of 99.9 kW or 100 kW: rated current is 200 A
  - For inverters with a power rating of 110 kW: rated current is 250 A
- Every inverter connected to the power grid must use an AC switch (D) with a rated voltage of  $\geq 500\text{V}$  a.c. The recommended rated current specifications are as follows:
  - For inverters with a power rating of 50 kW: rated current is 200 A
  - For inverters with a power rating of 60 kW: rated current is 250 A
  - For inverters with a power rating of 80 kW to 110 kW: rated current is 315 A
- It is recommended to use Fast Ethernet and WLAN for communication with inverters. When free 4G traffic of CommMod (L) runs out, users must replace an SIM card.

# Chapter 6 Location Requirements

## Tips

- Before installing the equipment, please be sure to carefully read the following installation requirements. The company will not be liable for any functional abnormalities or damages arising from the operation of the equipment if the installation requirements are not followed, even in cases leading to personal safety incidents.
- During actual installation, the selection of installation location should comply with local firefighting, environmental protection regulations, and other relevant laws. The specific installation location planning should be subject to the installer or engineering, procurement, and construction (EPC) contracts.

## Installation Environment Requirements

- Do not install the equipment in a smoky, flammable, or explosive environment.
- Do not install the equipment in an environment with conductive metal dust or magnetic dust.
- Do not install the equipment in an environment that is prone to mold and fungi.
- Avoid exposing the equipment to direct sunlight, rain, standing water, snow, or dust. Install the equipment in a sheltered place. Take preventive measures in operating areas prone to natural disasters such as floods, mudslides, earthquakes, and typhoons.
- Do not install the equipment in an environment with strong electromagnetic interference.
- The temperature and humidity of the installation environment should meet equipment requirements.
- The equipment should be installed in an area that is at least 500 m away from corrosion sources that may result in salt damage or acid damage (corrosion sources include but are not limited to seaside, thermal power plants, chemical plants, smelters, coal plants, rubber plants, and electroplating plants).
- In areas with good marine environments (such as Norway, where the nearshore salinity is  $\leq 28$  psu), the mounting distance of the device from the coastline can be appropriately relaxed to  $\geq 200$  m.
- If the outer surface of the device is damaged, please repaint the device in time.

## Installation Location Requirements

- Do not tilt the equipment or place it upside down. Ensure that the equipment is horizontally installed.
- Do not install the equipment in a place with fire hazards or is prone to moisturizing.
- Do not install the equipment in a sealed, poorly ventilated location without fire protection measures and difficult access for firefighters.
- Do not install the equipment under water sources, including but not limited to water pipes and air conditioner outlet windows, where condensate or water leakage may occur. Otherwise, liquid may enter the equipment and cause short circuit.
- Do not install the equipment in mobile scenarios such as recreational vehicles, cruise ships, and trains.

- The equipment is hot when it is operating. If the equipment is installed indoors, please ensure good indoor ventilation and avoid significant indoor temperature rise by more than 3°C while the equipment is operating. Otherwise, the equipment will be derated.
- The equipment generates heat when it is operating. Do not install the equipment in areas easily accessible to heat dissipation surfaces.
- You are advised to install the equipment in a location where you can easily access, install, operate, maintain it, and view the indicator status.
- The on-grid/off-grid switchover makes noise. It is recommended that the equipment be installed near the AC distribution box, away from the rest area.
- The recommended length for the AC cable between the inverter and the upstream transformer should be  $\leq 600$  meters. If the length exceeds 600 meters, it may affect the parallel operation of the inverters. Please contact Sigenergy for further advice.

## Installation Base Requirements

- Do not install the equipment on a flammable base.
- The installation base should meet the load-bearing requirement and should be free of adverse geological conditions including but not limited to rubber soil and soft soil. Solid brick-concrete structures and concrete walls are recommended.
- The installation base should be flat, and the installation area should meet the installation space requirements.
- No plumbing or electrical alignments should be inside the installation base to avoid potential drilling hazards during equipment installation.
- If the equipment is installed in a public place other than work and living areas (such as parking lots, stations, factories, etc.), please install a protective net outside the equipment and erect safety warning signs for isolation. Do not allow unrelated personnel to approach the inverter to avoid personal injury or property loss caused by accidental contact by non-professional personnel or other reasons during the operation of the equipment.

### Tips

- To ensure optimal performance of the device, it is suggested that the installation distance between the device and surrounding obstacles be planned with reference to the diagram. If the installation site is well-ventilated, the optimal solution may be deployed based on actual conditions.
- To facilitate subsequent maintenance (such as routine inspection or disassembly of the fan), it is suggested that a clearance of at least 400 mm be reserved on the left side of the device.

### PV-only installation scenario(PV-only and HYA models)

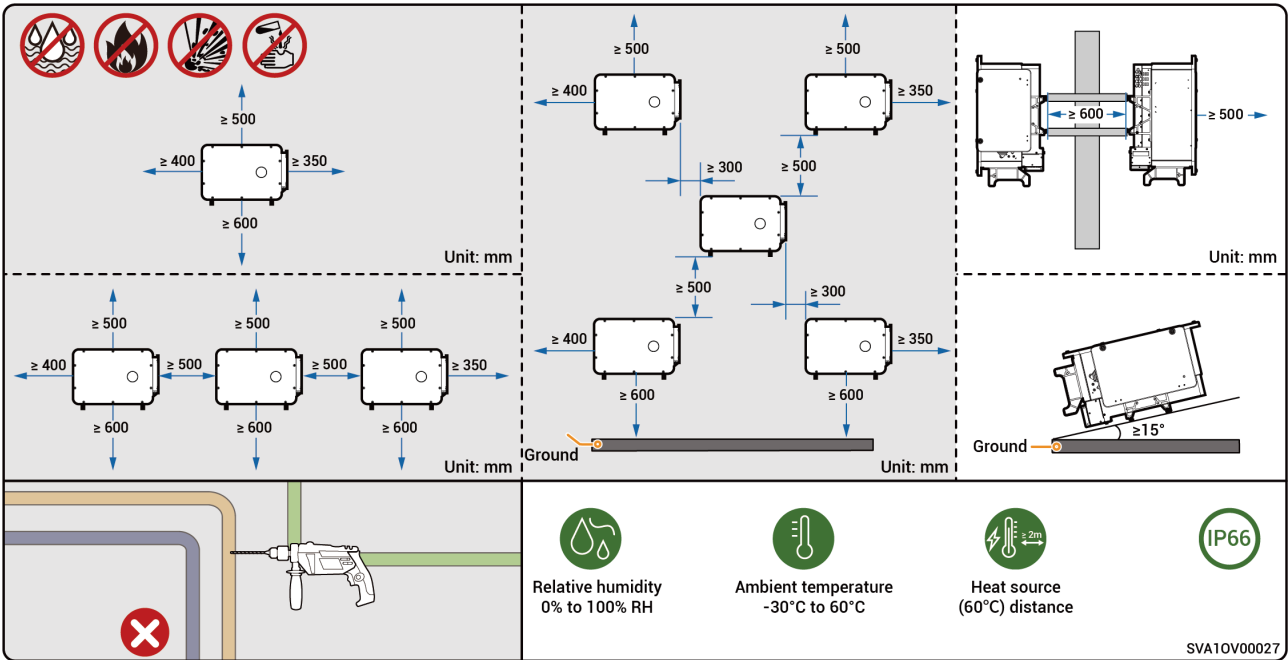

### PV-only installation scenario(HYB models)

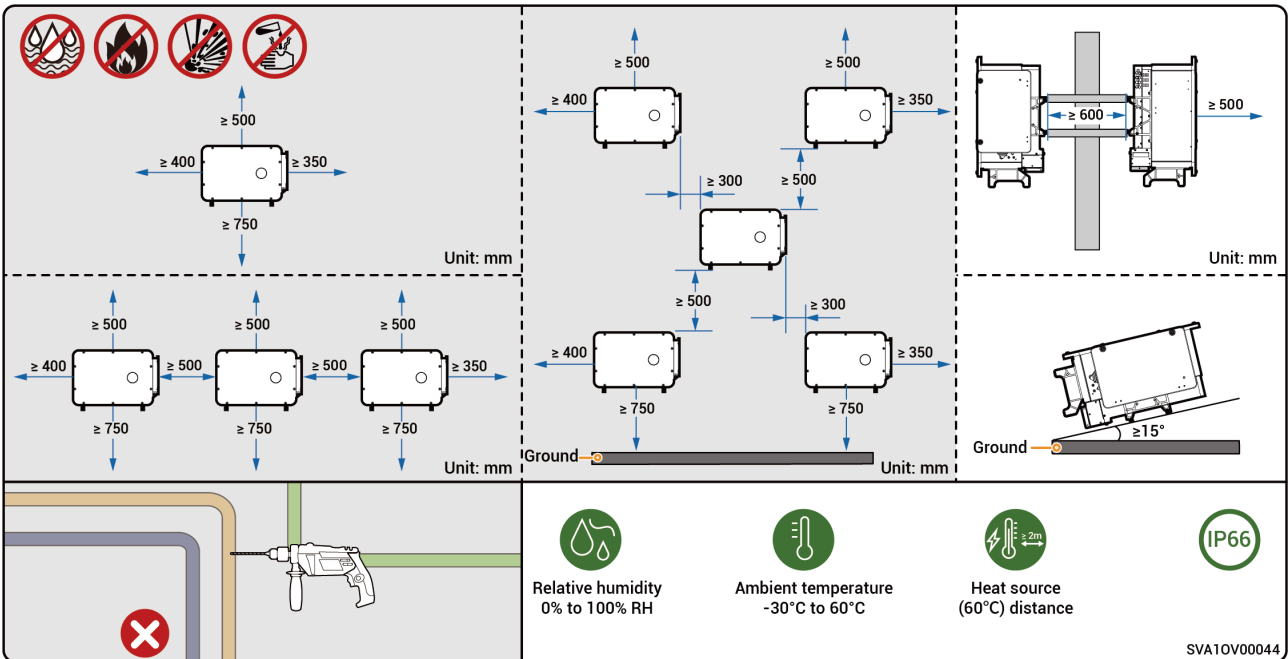

### Tips

- To ensure optimal performance of the device, it is suggested that the installation distance between the device and surrounding obstacles be planned with reference to the diagram. If the installation site is well-ventilated, the optimal solution may be deployed based on actual conditions.

## Tips

- To ensure unobstructed access for installation tools (such as lifting tools or forklifts), it is suggested that a clearance of at least 1500 mm be reserved in front of the battery cluster, which may be adjusted based on actual conditions.
- After installation, please ensure that there is no water accumulation at the bottom of the device, and add drainage channels if necessary.

## PV-storage installation scenario

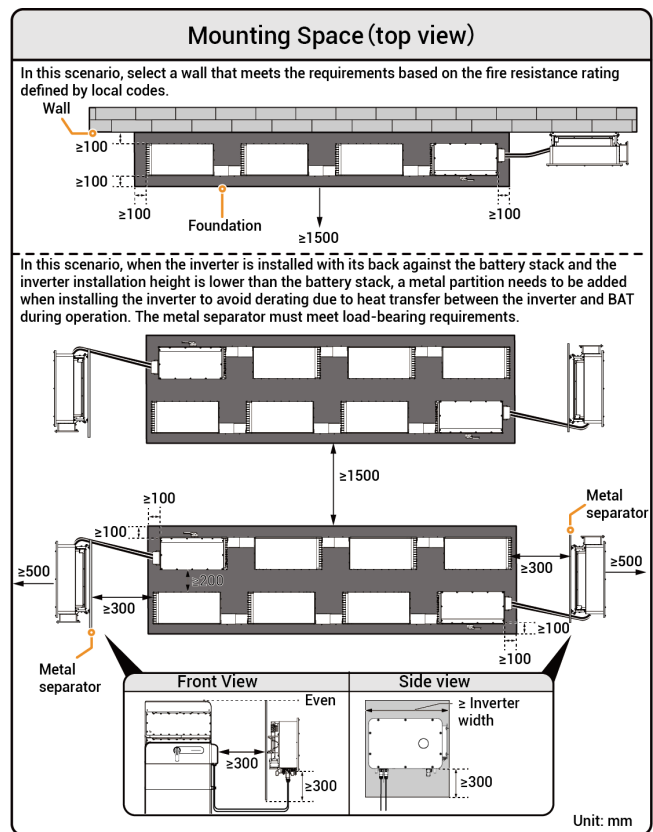
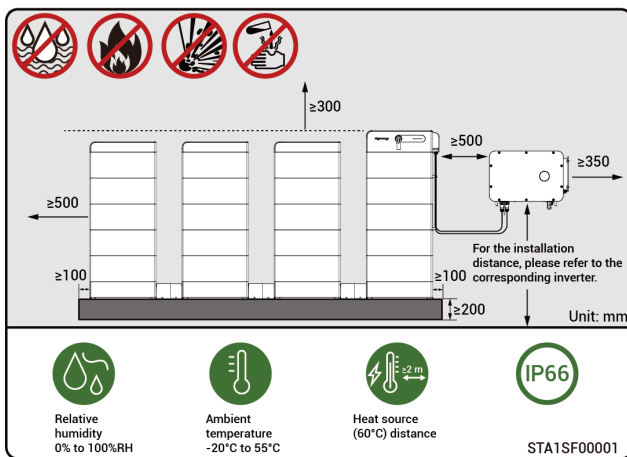

# Chapter 7 System Operation

## 7.1 Operational Mode

### Tips

The energy storage system supports multiple working modes, Some countries support Load Shedding Mode, VPP Scheduling-evergen Mode, which is subject to the App interface display.

### Sigen AI Mode

By obtaining local peak and valley electricity prices and weather data, combined with user electricity consumption habits, the Sigen AI Mode can customize intelligent electricity usage solutions to maximize customers' cost savings.

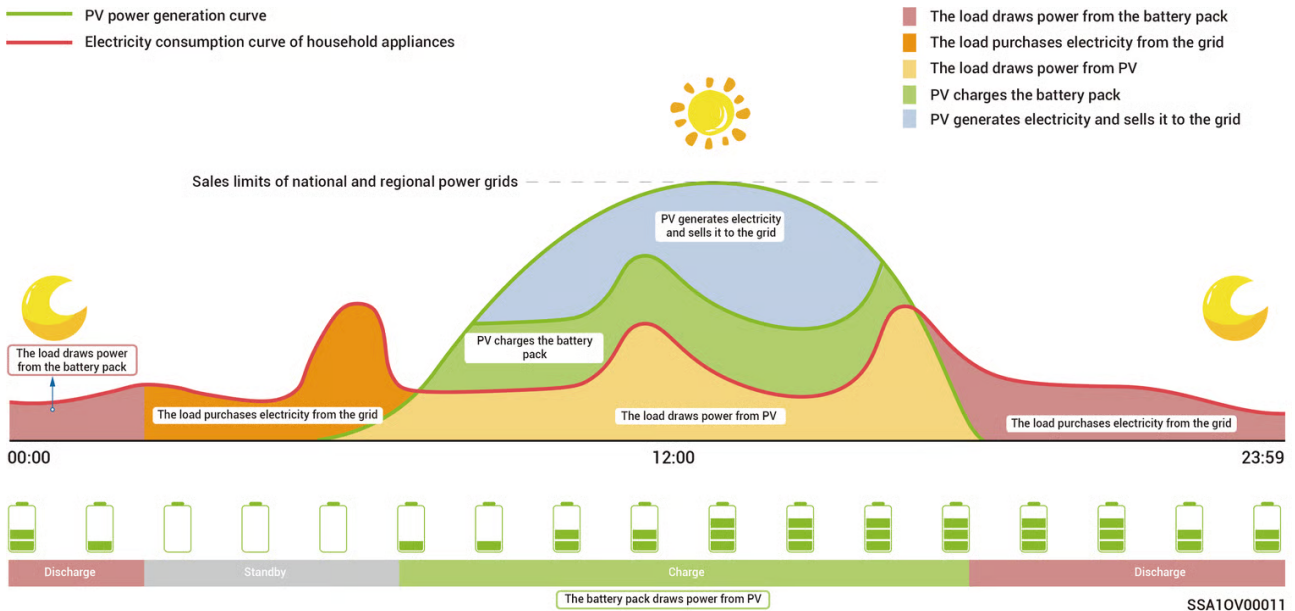

### Self-Consumption Mode

- When there is sufficient solar power, the electric energy generated by the PV system will first be used to power the loads, with any excess energy being stored in the batteries. Any remaining surplus energy will be sold to the grid. When there is insufficient solar power, the batteries will release electric energy to loads. By increasing the self-consumption ratio of the PV system and improving the self-sufficiency ratio of household energy, you can effectively save on your electric bills.
- This mode is suitable for areas with high electricity prices or zero-power grid connection restrictions.

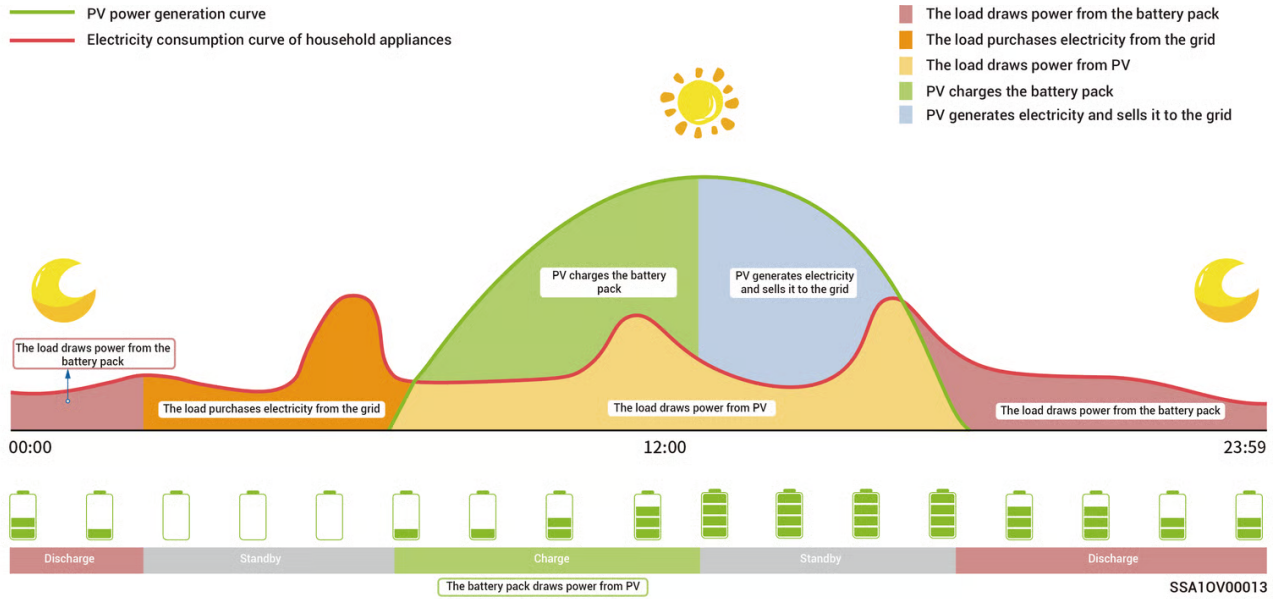

## Time-based Control Mode

- The charging period, discharging period, and self-consumption period need to be set manually. When electricity prices are high, the surplus power from photovoltaic power generation and battery power can be sold to the grid, and the battery can be charged during periods of low electricity prices to save electricity bills.
- If no period is set, the energy storage system will be in standby mode without discharging. The photovoltaic power will prioritize supplying the load, and the surplus power will be used for charging energy storage system.\*
- Up to 24 charging and discharging or self-consumption periods can be set.
- It is suitable for areas with peak and valley electricity prices and significant price differences.

\*When entering this period, the battery capacity will be recorded. When the photovoltaic power is greater than the load, the remaining photovoltaic power will charge the battery. When the photovoltaic power is less than the load, the battery can be discharged to the load. However, when the battery capacity decreases and approaches the battery capacity value when entering this period, the battery will stop discharging.

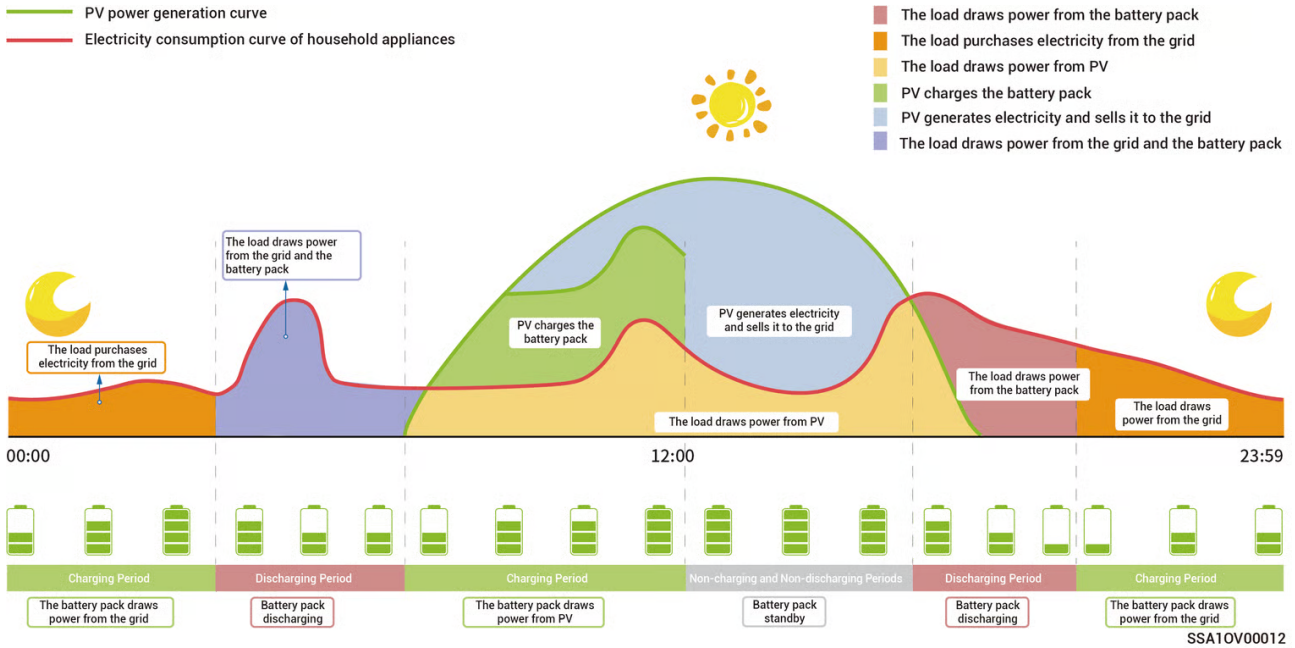

## Fully Feed-in to Grid Mode

- You can sell excess energy back to the grid and earn credits on your energy bill.
- In the daytime, when the PV power is greater than the maximum output capacity of the inverter, the inverter maintains the maximum output while storing excess energy in the batteries. When the PV power is lower than the maximum output capacity of the inverter or there is no PV power in the nighttime, the batteries are discharged to ensure that the inverter maximizes the output.

## VPP Scheduling-evergen Mode

Once registered with the VPP, your storage system will join the smart dispatching network. The App will show and auto-enable this mode.

## Remote EMS Mode

After setting to this mode will allows a third-party EMS to schedule parameters related to the power station and the product set by the company. Do not enter or exit this mode without the installer's confirmation.

## Load Shedding Mode

In areas with frequent power outages, you can add your region and schedule in this mode, and the system will fully charge the battery in advance as scheduled, ensuring that you have battery power available to supply the load during outages. (currently only supported in South Africa)

## 7.2 LED Indicator State









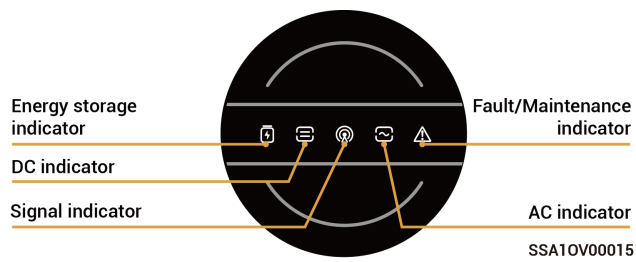

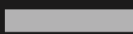







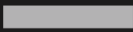









### Inverter Indicator

#### Tips

There are three types of indicators: a yellow indicator, see Light Language 1; a blue indicator, see Light Language 2; a purple indicator, see Light Language 3.

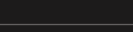

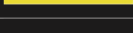
### Light Language 1

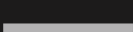

Indicator	Color	State	Description
		-	All SigenStacks lie dormant.
		Flash	SigenStack is charging.
		Breathing blink	All SigenStacks are connected but not running.
		Always on	SigenStack neither charges nor discharges.
		Flash	SigenStack is discharging.
		Always on	SigenStack disconnected.
		Always on	Some SigenStacks are faulty.
		-	The DC side is not connected.
		Breathing blink	The DC side is connected but not running.
		Always on	The DC side is running.
		Flash	The DC side is faulty.
		Always on	The inverter is faulty.
		-	The AC side is not connected.
		Breathing blink	The AC side is connected but not running.
		Always on	Grid-connected operation.
		Always on	Off-grid operation.
		Flash	The AC side is faulty.
		Always on	The inverter is faulty.
		-	The management system is not connected.
		Flash	App connects to the device hotspot.
		Always on	Connected to the management system using an FE or WLAN.
		Always on	Connected to the management system over 4G.
		Flash	Insufficient traffic for Sigen CommMod.
		Always on	Proximity password reset in progress.
		Flash	Ethernet port 1/2 abnormality
			-

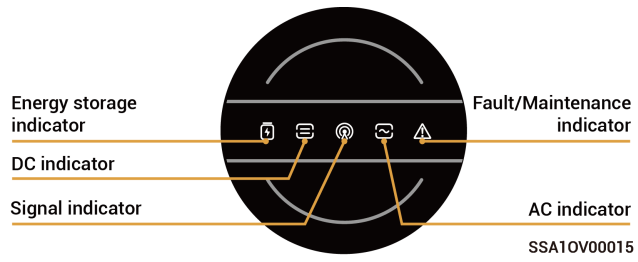

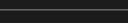





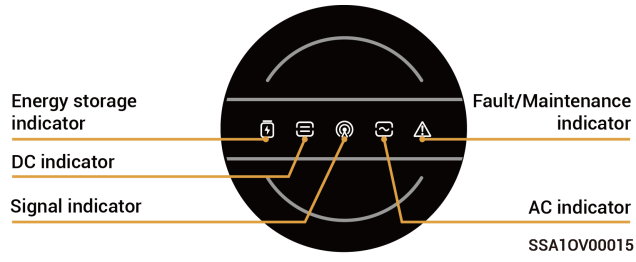

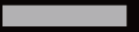









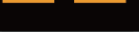





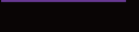

## Light Language 2

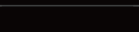

Indicator	Color	State	Description
		-	All SigenStacks lie dormant.
		Breathing blink	All SigenStacks are connected but not running.
		Always on	SigenStack neither charges nor discharges.
		Flash	SigenStack is charging.
		Flash	SigenStack is discharging.
		Always on	SigenStack disconnected.
		Always on	Some SigenStacks are faulty.
		-	The DC side is not connected.
		Always on	The DC side is connected but not running.
		Always on	The DC side is running.
		Flash	The DC side is faulty.
		Always on	The inverter is faulty.
		-	The AC side is not connected.
		Always on	The AC side is connected but not running.
		Always on	Grid-connected operation.
		Always on	Off-grid operation.
		Flash	Off-grid overload operation.
		Flash	The AC side is faulty.
		Always on	The inverter is faulty.
		-	The management system is not connected.
		Flash	App connects to the device hotspot.
		Always on	Connected to the management system using an FE or WLAN.
		Always on	Connected to the management system over 4G.
		Flash	Insufficient traffic for Sigen CommMod.
		Always on	Proximity password reset in progress.
		Flash	Ethernet port 1/2 abnormality
		-	No alarms and no local maintenance operations.

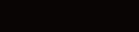
# Light Language 3

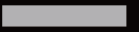

Indicator	Color	State	Description
		-	All SigenStacks lie dormant.
		Breathing blink	All SigenStacks are connected but not running.
		Always on	SigenStack neither charges nor discharges.
		Flash	SigenStack is charging.
		Flash	SigenStack is discharging.
		Always on	SigenStack disconnected.
		Always on	Some SigenStacks are faulty.
		-	The DC side is not connected.
		Always on	The DC side is connected but not running.
		Always on	The DC side is running.
		Flash	The DC side is faulty.
		Always on	The inverter is faulty.
		-	The AC side is not connected.
		Always on	The AC side is connected but not running.
		Always on	Grid-connected operation.
		Always on	Off-grid operation.
		Flash	Off-grid overload operation.
		Flash	The AC side is faulty.
		Always on	The inverter is faulty.
		Always on	Bypass mode. The grid supplies power to the load.
		-	The management system is not connected.
		Flash	App connects to the device hotspot.
		Always on	Connected to the management system using an FE or WLAN.
		Always on	Connected to the management system over 4G.
		Flash	Insufficient traffic for Sigen CommMod.
		Always on	Proximity password reset in progress.
		Flash	Ethernet port 1/2 abnormality
		-	No alarms and no local maintenance operations.

## Sigen CommMod Indicator

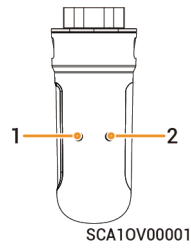

S/N	Name	State	Description
1	Power indicator	-	-
2	Network state indicator	Slow flashing (200 ms on/1800 ms off)	The network is being connected
2	Network state indicator	Slow flashing (1800 ms on/200 ms off)	Standby
2	Network state indicator	Quick flashing (125 ms on/125 ms off)	Data is being transferred

## Chapter 8 Equipment Installation and Wiring

- Only company authorized personnel should install and connect the equipment. For detailed operation methods, please refer to the installation guide corresponding to the device model.
- Parts and accessories supplied with the packing box are personal assets of the owner and must be kept safe.

## Chapter 9 mySigen App Query

The App can be downloaded in the following two ways. For details, see *mySigen App User Manual*.

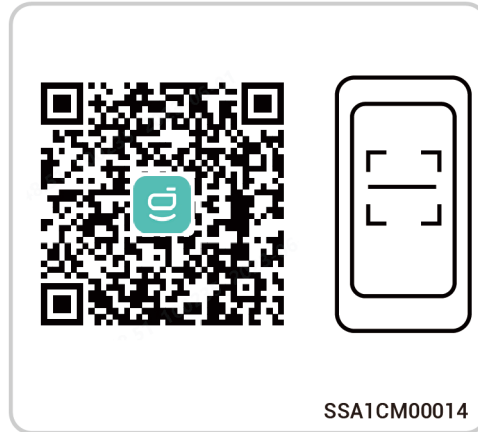

# Chapter 10 System Maintenance

## 10.1 Routine Maintenance

To ensure the long-term operation of the equipment, you are advised to perform routine maintenance according to this section.

Inspection Items	Inspection Method	Power Off or Not	Maintenance Interval
System cleaning	Check the device regularly for shielding and dirt. If so, clean it up. Do not use tools that may cause electric shock or insulation damage, such as wire brushes and during the cleaning process.	Yes	Once every 3 months
System operating state	<ul style="list-style-type: none"> <li>● Check whether the equipment appearance is damaged or deformed.</li> <li>● Check for noise when the equipment is operating.</li> <li>● Check whether the equipment parameters are correctly set when the equipment is operating.</li> </ul>	No	Once every 6 months
Electrical connection	<ul style="list-style-type: none"> <li>● Check whether cable terminals are tightly connected.</li> <li>● Check whether cable sheath is damaged.</li> <li>● Check whether scratches exist on the surface where the cable contacts the metal.</li> <li>● Check whether scratches exist on the surface where the cable contacts the metal.</li> </ul>	Yes	Check once every 6 months after creating new systems and once every 6 to 12 months thereafter.

Inspection Items	Inspection Method	Power Off or Not	Maintenance Interval
Grounding reliability	Check whether the ground cable is properly and reliably connected.	No	Check once every 6 months after creating new systems and once every 6 to 12 months thereafter.

## 10.2 System Power-on/Power-off

### Danger

#### High Voltage and Hazards:

Wear personal protective equipment such as insulating gloves, insulating shoes, and safety hats while operating the equipment. Do not wear conductive accessories such as metal bracelets, rings, or necklaces.

### System power-off

1. Power the equipment off in the App.

#### Owner's Account

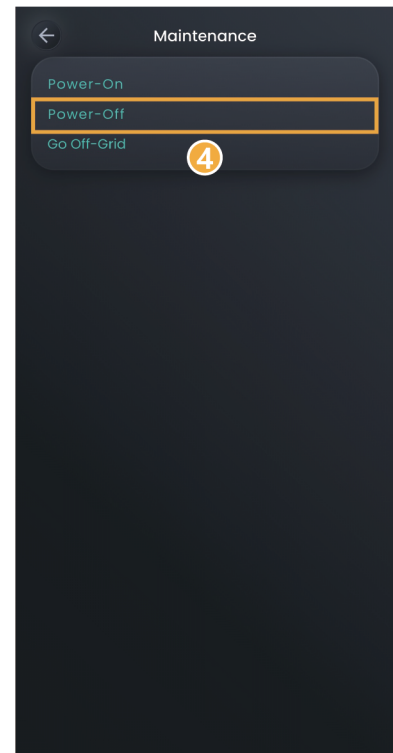
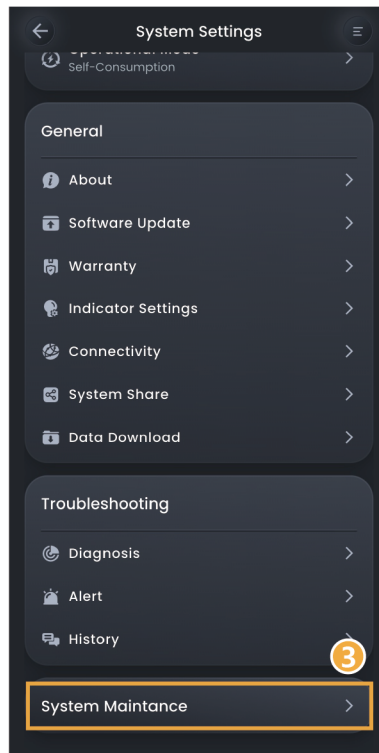
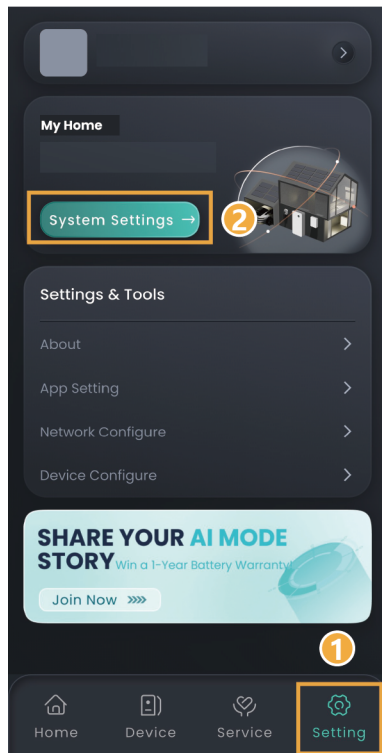

#### Installer's Account

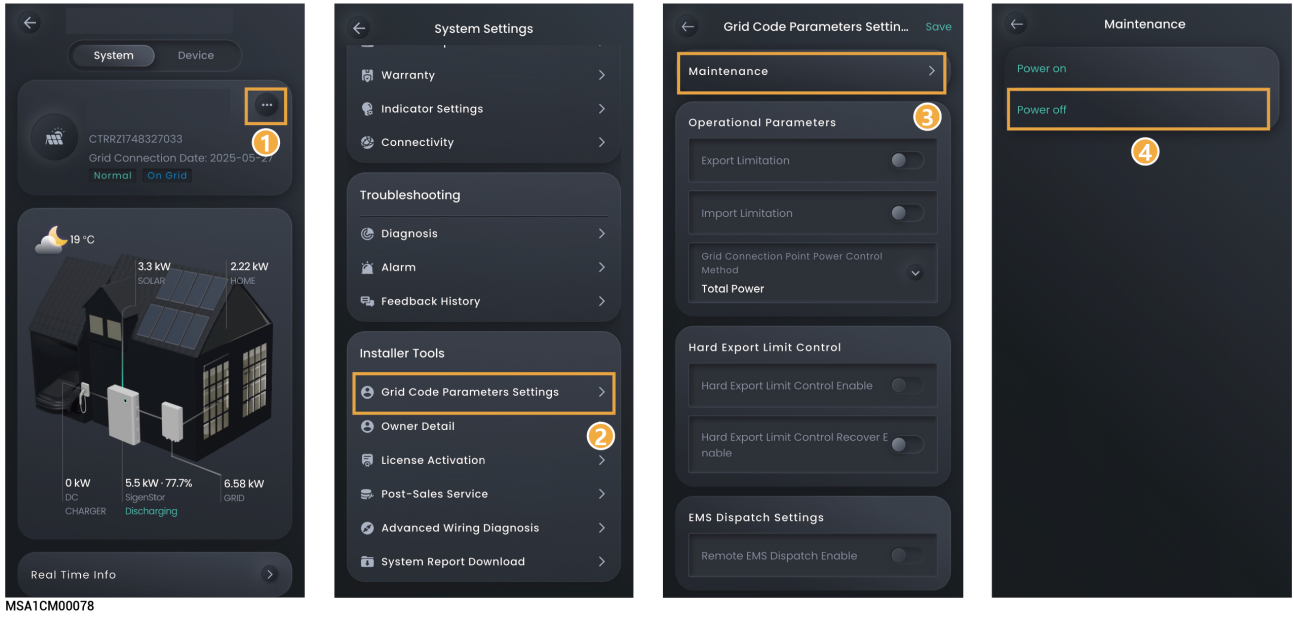

MSA1CM00078

2. Turn off the switch connected to the equipment in the backup power distribution panel.
3. Turn DC SWITCH on the equipment to the OFF position.
4. After all LED indicators on the equipment go off, wait for the corresponding time as indicated on the label on the equipment before proceeding.

### **Warning**

**There is residual current and the equipment is hot immediately after the equipment is powered off. Operating the equipment immediately upon power off may lead to electric shock or burns.**

### System power-on

1. Turn DC SWITCH on the equipment to the ON position.
2. Turn on the switch connected to the equipment in the backup power distribution panel.
3. Power the equipment on in the App. For details, see Step 1 in System power-off.

## 10.3 Low SOC

The self-discharge characteristic of battery pack will cause power loss. If the equipment is not charged for a long time, it may be damaged due to overdischarge of power. When the battery is low, charge the equipment in time.

Under normal circumstances, the equipment can charge itself according to the running condition. If the equipment cannot be charged, please contact your sales agent in time and deal with it within the specified time. If the battery capacity is lost or irreversible damage is caused due to the delay, the company will not be liable.

- When the battery power is greater than or equal to 10%, charge within 30 days.
- When the battery power is less than or equal to 0% and less than 10%, charge within 7 days.

### **Scenarios that may cause a charge failure (including but not limited to) :**

- The PV side has no input, and the power grid side is powered off for a long time.
- The equipment is faulty.
- Parameters are not set correctly.

## 10.4 Emergency Treatment

### Emergency in case of Fire

#### Danger

- Please shut down the equipment or disconnect the main power switch when it is safe.
- The high temperature may distort or damage the battery pack, resulting in electrolyte overflow or toxic gas leakage. Do not go near the battery pack and wear protective equipment.
- If the fire is small, use carbon dioxide or ABC dry powder extinguisher to extinguish the fire.
- If the fire is spreading, evacuate the building or equipment area immediately and call the fire department. Re-entry to burning buildings is prohibited.
- Do not touch or come into contact with high voltage components during fire fighting, due to the risk of electric shock.
- After extinguishing the fire, do not use the equipment, please contact your installer.

### Emergency in case of Flood

#### Danger

- Please shut down the equipment or disconnect the main power switch when it is safe.
- If the battery pack is submerged, do not touch it to avoid the danger of electric shock.
- After the flood waters recede, do not use the equipment. Please contact your installer.

### Emergency in case of Battery Pack Malfunctions

#### Danger

- When the battery pack has abnormal odor, electrolyte leakage, or heat, do not touch it, and contact professional personnel immediately. Professionals must wear protective equipment such as goggles, rubber gloves, gas masks, and protective clothing to protect themselves.
- The electrolyte is corrosive and contact may cause skin irritation or chemical burns. In case of accidental contact with the electrolyte, take the following measures immediately:
  - Inhalation: Evacuate the contaminated area, keep fresh air circulating, and seek immediate medical help.
  - Eye contact: Flush eyes with plenty of water for at least 15 minutes. Do not rub eyes. Seek medical help immediately.
  - Skin contact: Wash the contact area with plenty of soapy water and seek medical help immediately.
  - Ingestion: Induce vomiting and seek medical help immediately.
- Do not continue to use abnormal battery packs, please contact your installer.

## Emergency in case of Battery Pack Drops or Impacts

- If there is an obvious odor, smoke, or fire, keep away from the equipment immediately and contact professional personnel.
- Do not use the battery pack if it has been dropped or hit. Please contact your installer.

# Chapter 11 Inverter and Battery Pack Disposal

## Removing the Inverters

### Warning

Cut off both the DC and AC power supplies before removing the inverters.

Perform the following operation before removing the inverters:

1. Disconnect all electrical connections of the inverters, including the RS485 communication cable, DC input cable, AC output cable, and protection ground (PGND) cable.
2. Remove the inverters from the mounting kit.
3. Remove the mounting kit.

## Scrapping the Inverters

When the inverter and battery pack reaches the end of its useful life, please dispose of it according to the applicable electrical waste disposal regulations in the installation location.

# Chapter 12 Appendix

## Technical Parameter

For details about equipment parameters, see the Datasheets of the product.