

# SiGen EV DC Charging Module Installation Guide

SiGenStor EVDC 12 (5S2, 7.5S2, 10S2, 7.5GBT, 10GBT)  
SiGenStor EVDC 25 (5S2, 7.5S2, 10S2, 7.5GBT, 10GBT)

Version: 03  
Release date: 2025-10-28

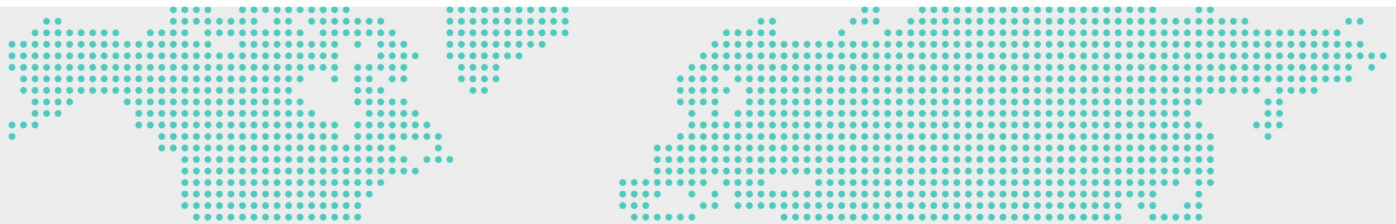

## ⚠ Caution

- Only trained or qualified persons with electrical engineering knowledge can work directly on the equipment.
- Operators should be familiar with national and local laws, regulations, and standards, and the compositions and operating principles of relevant systems.
- Before performing operations, carefully read the document and the operation requirements and precautions in the Precautions section. If any damage is caused by failure to perform operations under requirements, the equipment is not covered by the warranty.

## 1 Introduction

### 1.1 Appearance and Dimensions

SigenStor EVDC 12 (5S2, 7.5S2, 10S2)  
SigenStor EVDC 25 (5S2, 7.5S2, 10S2)

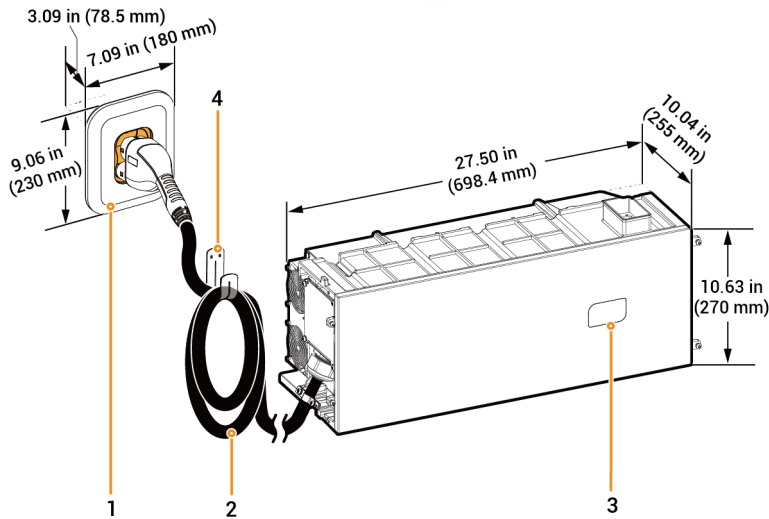

No.	Description
1	Charging connector holder for placing the charging connector
2	Charging connector cable
3	RFID card reading area
4	Cable holder for storing the charging cable

SEA10V00014

**SigenStor EVDC 12 (7.5GBT, 10GBT)  
SigenStor EVDC 25 (7.5GBT, 10GBT)**

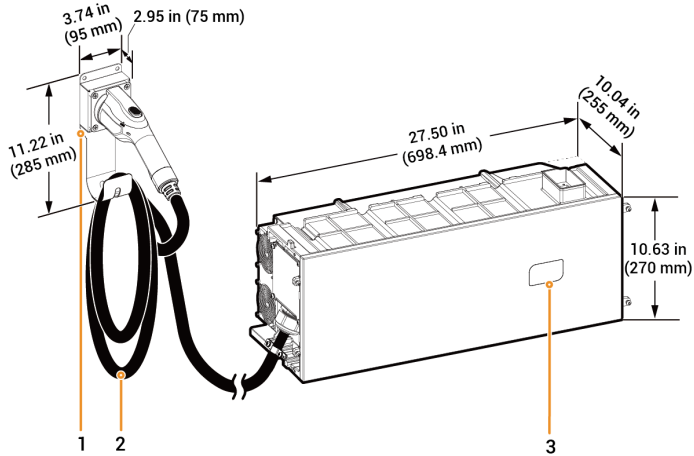

SEA10V00014

No.	Description
1	Charging connector holder for placing the charging connector
2	Charging connector cable
3	RFID card reading area

## 1.2 Typical Installation Scenarios

Sigen EV DC Charging Module (hereinafter referred to as SigenStor EVDC) can be used with our inverters (SigenStor EC, SigenStor AC, and Sigen Hybrid series) and battery pack (SigenStor BAT) in the following different installation scenarios.

No.	Component Configuration	Installation Status of Components
1	SigenStor EC/SigenStor AC/Sigen Hybrid + SigenStor EVDC + Battery Pack	Adding the SigenStor EVDC, with other components installed
2		Newly installing the SigenStor EVDC and other components
3	Sigen Hybrid + SigenStor EVDC	Adding the SigenStor EVDC, with other components installed
4	Sigen Hybrid + SigenStor EVDC	Newly installing the SigenStor EVDC and other components

## 2 Inspections Before Installation

- Check whether the components are entirely supplied against the packing list and whether the appearance is in good condition. For any problem, contact your sales representative.
- Check and ensure the completeness of personal protective equipment and installation tools; replenish if necessary.
- Check and ensure the correctness of quantity and specifications of the installer-provided cables; re-prepare if necessary.

### Safety Devices



Safety hat



Goggles



Dust mask



Protective gloves



Insulating gloves



Insulating shoes

### Installation Tools

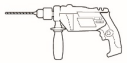

Power drill



Vacuum cleaner

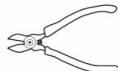

Wire cutter

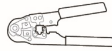

Crimp tool



Crimping pliers



Wire stripper



Scissors



Cable ties



Heat shrinkable sleeve



Heat gun

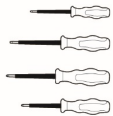

Insulated screwdriver set  
(bit length  $\geq 7.87$  in/200 mm)



Digital adjustable open-end torque socket wrench  
(Opening  $\geq 2.09$  in/53 mm)



Marker



Rubber mallet

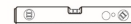

Level



Tape measure

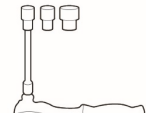

Insulated torque socket wrench set  
(extension bar  $\geq 7.87$  in/200 mm)

### (Optional) Installer-provided Cables

For the configuration with an inverter + SigenStor EVDC + battery pack, where the SigenStor EVDC is an additional configuration, check if the owner has a cable of sufficient length in the existing equipment. If available, skip this step. If not, prepare a cable with the appropriate specifications.

## 3 Site Requirements

### Tips

- The warranty applies when the equipment has been installed properly for its intended use and in accordance with the operating instructions.
- During actual installation, the selection of installation location should comply with local firefighting, environmental protection regulations, and other relevant laws. The specific installation location planning should be subject to the installer or engineering, procurement, and construction (EPC) contracts.

#### Installation Environment

- Do not install the equipment in smoky, flammable, or explosive environment.
- Avoid exposing the equipment to direct sunlight, rain, standing water, snow, or dust. It is suggested to install the equipment in a sheltered place. Take preventive measures in operating areas prone to natural disasters such as floods, mudslides, earthquakes, and typhoons.
- Do not install the equipment in an environment with strong electromagnetic interference.
- The temperature and humidity of the installation environment should meet equipment requirements.
- The equipment should be installed in an area that is at least 1640.42 ft (500 m) away from corrosion sources that may result in salt damage or acid damage. Corrosion sources include but are not limited to seaside, thermal power plants, chemical plants, smelters, coal plants, rubber plants, and electroplating plants.

#### Installation Base

- Do not install the equipment on a flammable base.
- The installation base should meet the load-bearing requirement. Solid brick-concrete structures, concrete walls, and floors are recommended.
- The installation base should be flat, and the installation area should meet the installation space requirements.
- No plumbing or electrical alignments are allowed inside the installation base to avoid potential drilling hazards during equipment installation.

#### Installation Location

- Do not tilt the equipment or place it upside down. Ensure that the equipment is horizontally installed.
- Do not install the equipment in places easily touched by children.
- Do not install the equipment in a place with fire hazards or is prone to moisturizing.
- The equipment produces sound when it is operating. Please install the equipment in a place with appropriate distance at which there is no impact to daily work and life.
- Do not install the equipment in a sealed, poorly ventilated location without fire protection measures and inaccessible for firefighters.
- The equipment is hot when it is operating. If the equipment is installed indoors, please ensure good indoor ventilation and avoid significant indoor temperature rise by more than 37.4°F (3°C) while the equipment is operating. Otherwise, the equipment will be derated.
- It is recommended to install the equipment in a location where you can easily access, install, operate, and maintain it, and view the indicator status.
- Do not place the equipment in the vehicle passage when installed in a garage to avoid collisions.
- Install the equipment near the parking space. Refer to the figure for the installation distance.

SigenStor EVDC can only be installed underneath the inverter.

Relative humidity  
5% to 95%RH

Ambient temperature  
-22°F to 140°F  
(-30°C to 60°C)

Heat source  
(140°F/60°C)  
distance  
≥6.56ft  
≥2m

IP66

SEA1SF0002

Charging port position

Model	R (ft)	R (m)
SigenStor EVDC 12 5S2, SigenStor EVDC 25 5S2	15.91	4.85
SigenStor EVDC 12 (7.5S2, 7.5GBT) SigenStor EVDC 25 (7.5S2, 7.5GBT)	24.11	7.35
SigenStor EVDC 12 (10S2, 10GBT) SigenStor EVDC 25 (10S2, 10GBT)	32.32	9.85

Charging port position

Model	R (ft)	R (m)
SigenStor EVDC 12 5S2, SigenStor EVDC 25 5S2	=16.4 - N×0.958	=5 - N×0.292
SigenStor EVDC 12 (7.5S2, 7.5GBT) SigenStor EVDC 25 (7.5S2, 7.5GBT)	=24.61 - N×0.958	=7.5 - N×0.292
SigenStor EVDC 12 (10S2, 10GBT) SigenStor EVDC 25 (10S2, 10GBT)	=32.81 - N×0.958	=10 - N×0.292

## Tips

There will be errors in the actual distance under different installation environments, and the figure is for reference only.

## 4 Installation

### 4.1 Inverter + SigenStor EVDC + Battery Pack

#### 4.1.1 Adding SigenStor EVDC

#### Danger

Do not perform operations on the equipment with power on. Before operation, make sure to disconnect all power supplies of the equipment, including power switches on the power grid side, inverters, and diesel generators.

- 1 (Optional) Determine the mounting hole positions of the inverter after installing the SigenStor EVDC. Drill holes and install expansion bolts accordingly.

Historical scenario of 1 inverter + 1 battery pack

Skip this step if the inverter is not wall-mounted.

Historical scenario where the inverter has been wall-mounted

#### Tips

- Expansion bolts required in this step are supplied by users. M8 × 120 SS sleeve expansion bolts with washers are recommended.
- Drilling will generate dust. Do not remove the decorative cover before drilling.

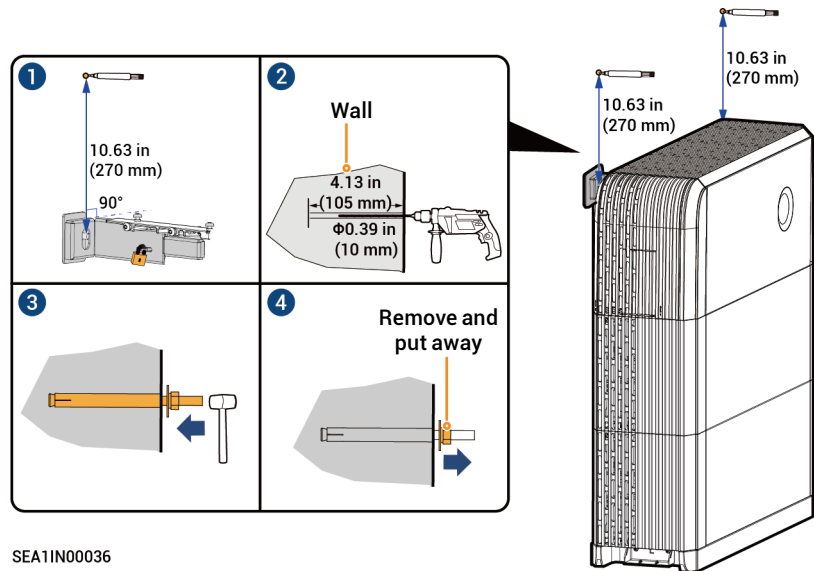

SEA1IN00036

## Historical scenario of 1 inverter + 2 battery packs

### Tips

- Expansion bolts required in this step are supplied by users. M8 × 120 SS sleeve expansion bolts with washers are recommended.
- Obtain the wall connectors required for this scenario from the historical "Installation package". If you can not find the wall connector, please contact your sales representative.
- Drilling will generate dust. Do not remove the decorative cover before drilling.

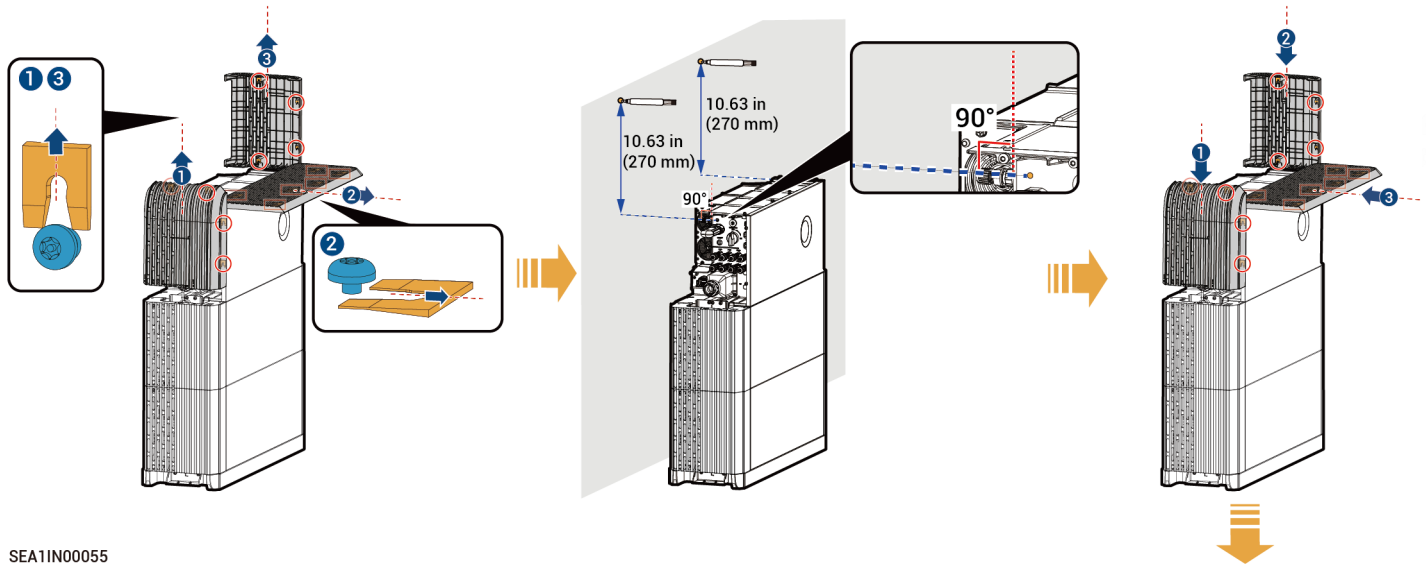

SEA1IN00055

Historical scenario of 1 inverter + 2 battery packs

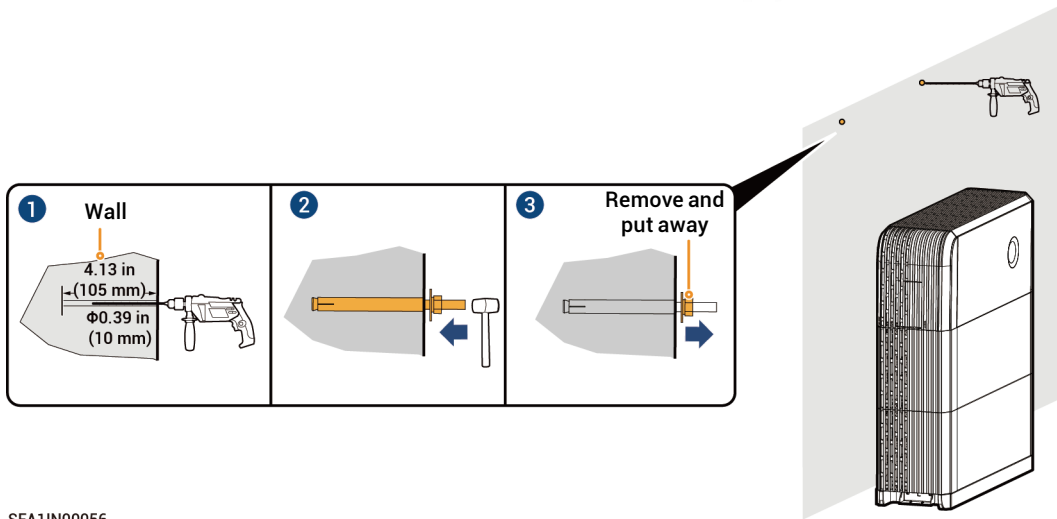

2

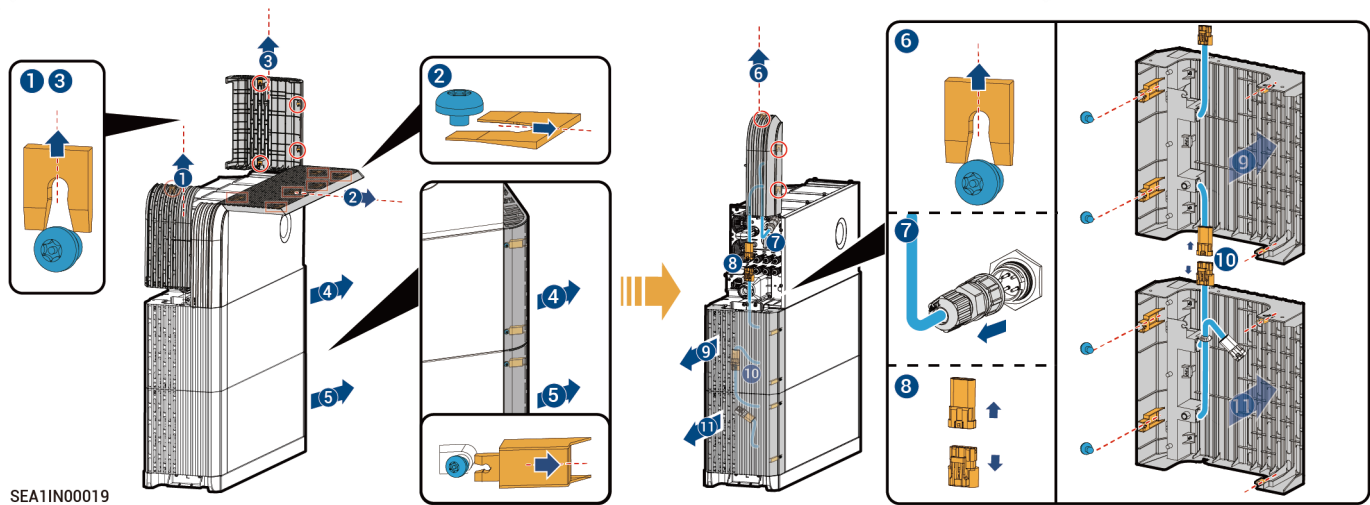

**3** Remove the cable connected to the inverter and remove the inverter.

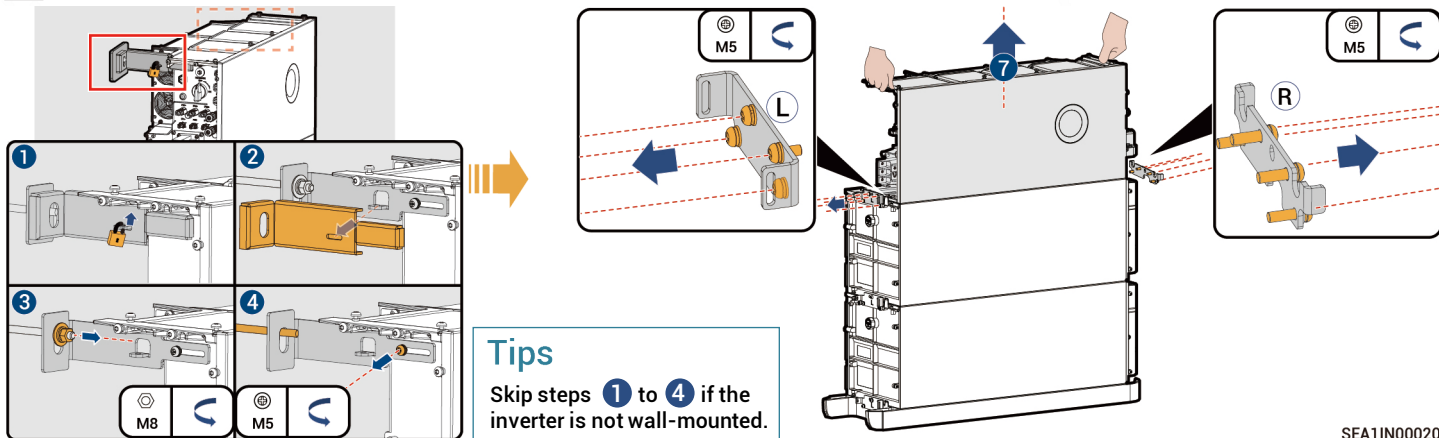

SEA1IN00020

**4**

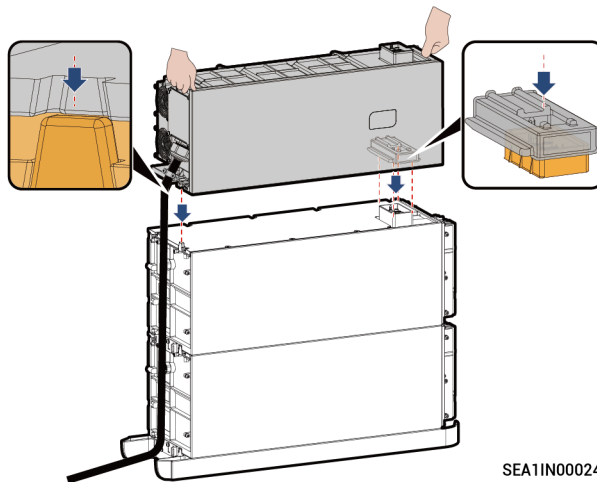

SEA1IN00024

5

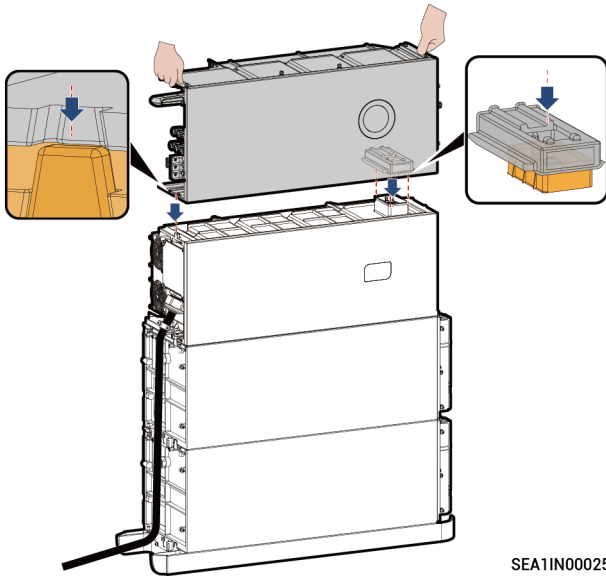

SEA1IN00025

6

## Tips

A cascade piece has two available appearance specifications.  
The actual application shall prevail.

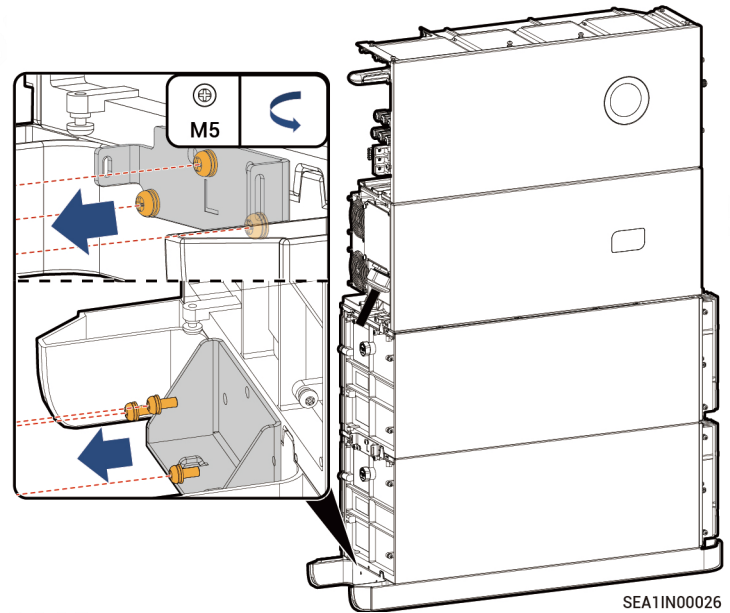

SEA1IN00026

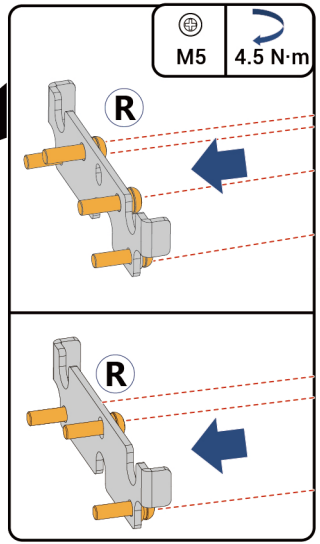
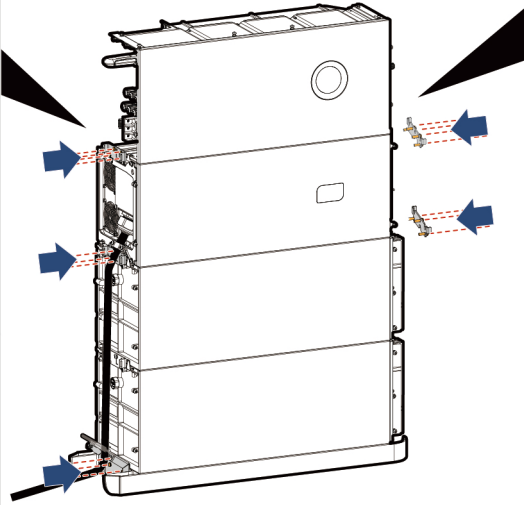
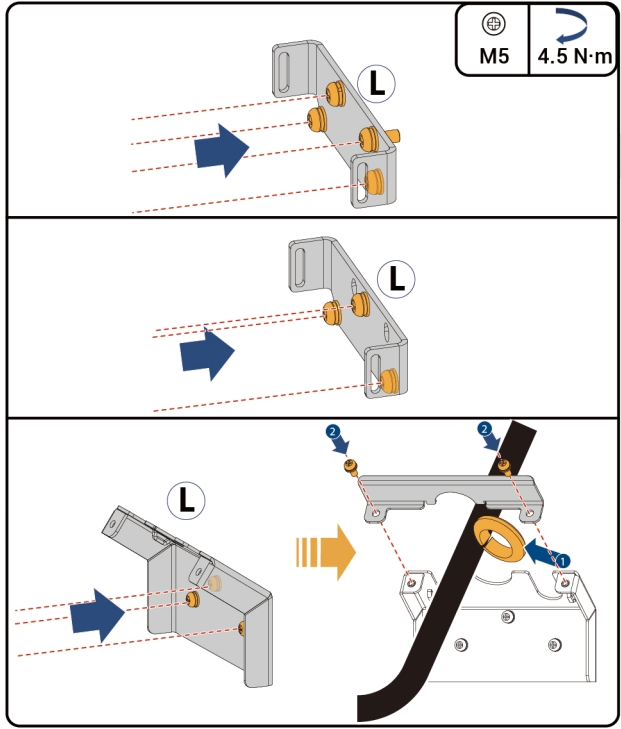

SEA1IN00027

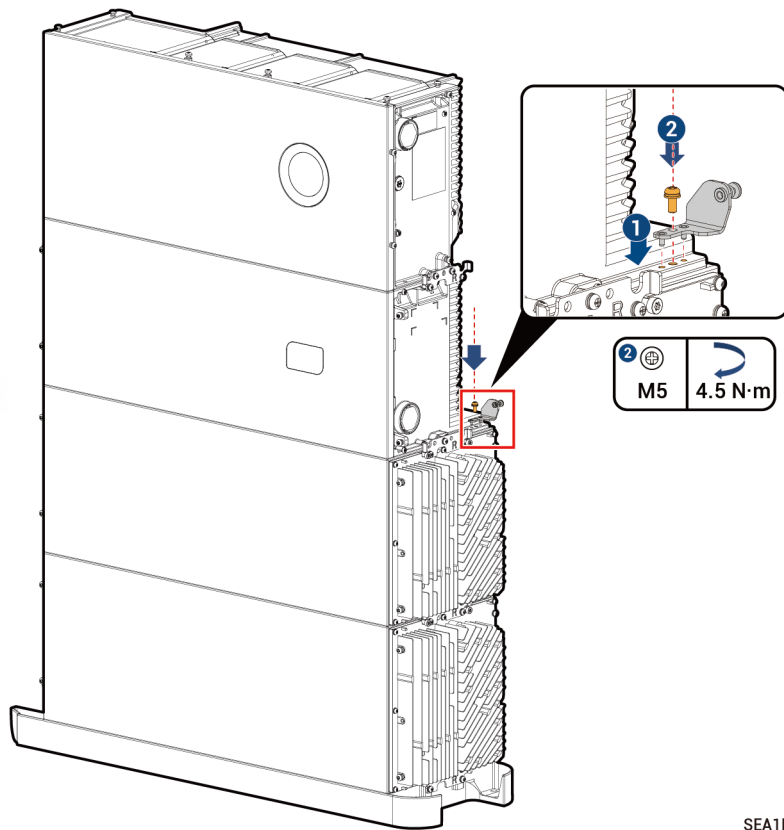

SEA1IN00058

9 (Optional) Follow these steps to mount the inverter to the wall securely.

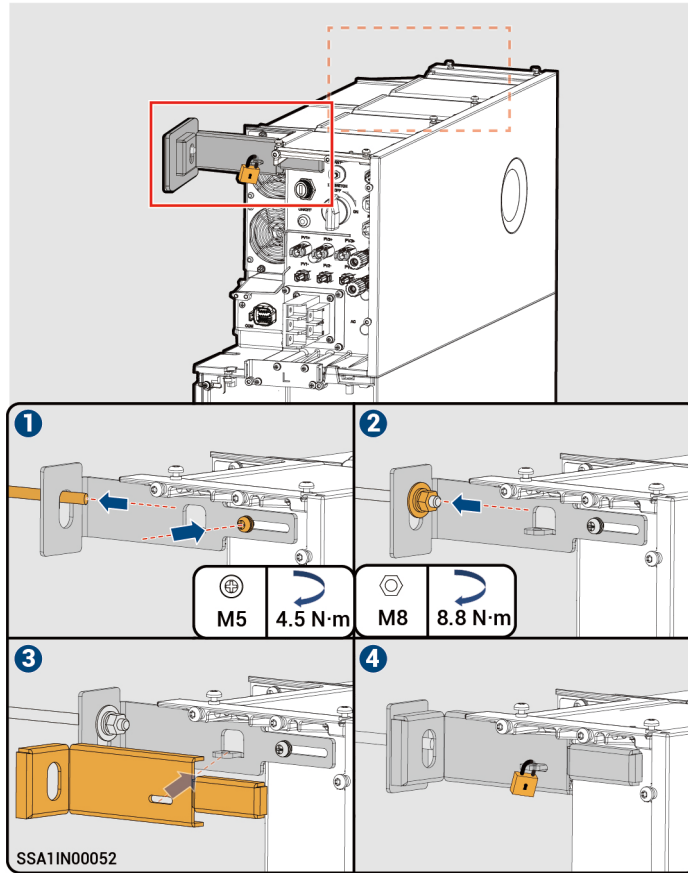

## 10 Reinstall the inverter cable.

### Tips

If the cable length is insufficient during reinstallation, please refer to the corresponding model's SigenStor Home Installation Guide for specific installation instructions.

## 11

### Caution

- The decorative cover used in step 1 is supplied with the SigenStor EVDC.
- If the strip light shows abnormal status when the equipment is powered on, check if the pins in the male connector is tilted. If tilted, straighten them out and then reconnect the corresponding male and female connectors, or reconnect the terminal in step 6 to resume normal operation.

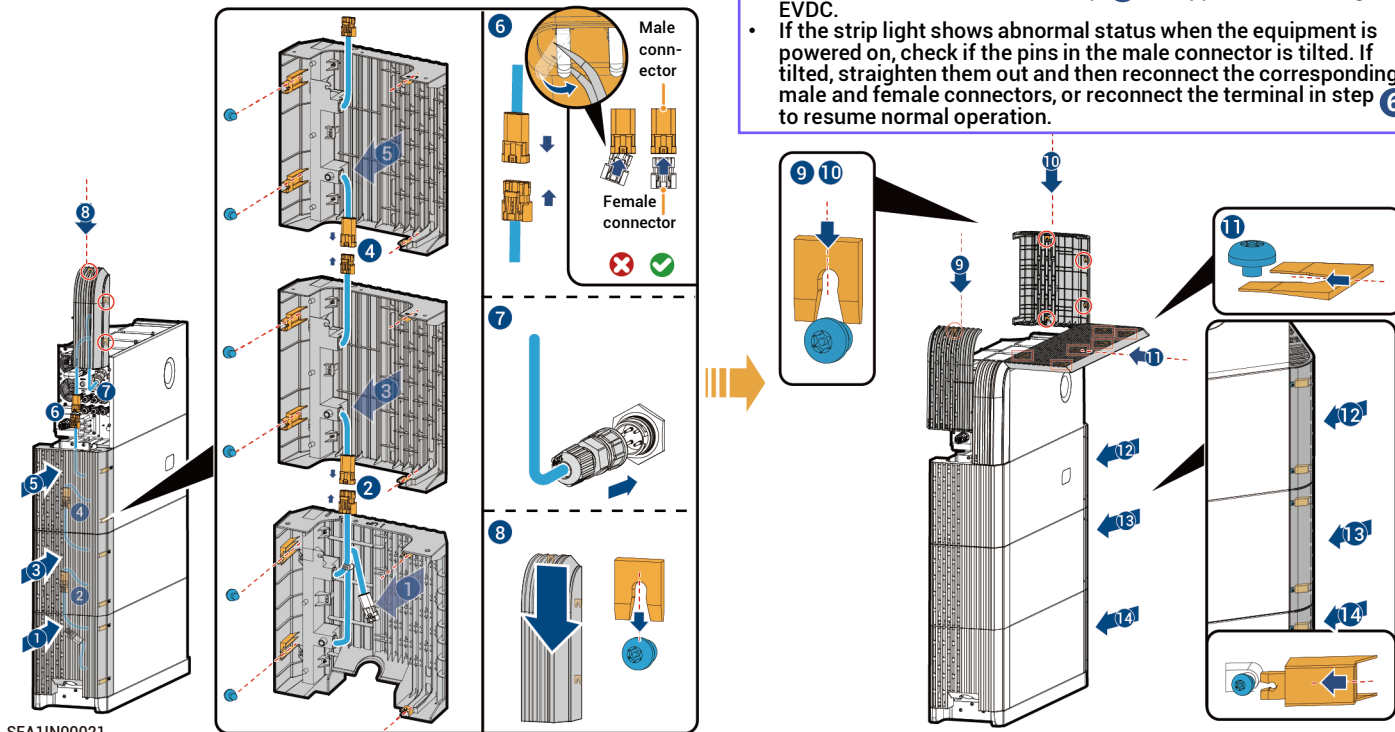

SEA11N00021

## 4.1.2 Newly Installing All Components

### Tips

- Install the battery pack, SigenStor EVDC, and inverter in sequence.
- This section introduces the installation procedure of SigenStor EVDC only. For detailed instructions on installing the inverter and battery pack, please refer to the SigenStor Home Installation Guide for the specific model.

- 1 Determine the mounting hole positions of the inverter after installing the SigenStor EVDC. Drill holes and install expansion bolts accordingly.

### Wall Mounting

### Tips

INV1 is the mounting hole on the left side of the inverter for wall installation, while INV2 is the mounting hole on the right side for wall installation.

### Calculation formula for punch height:

L1 and L2 should be measured from the upper surface of the base:  
 $L1 = N \times 10.63 \text{ in (270 mm)} + 10.63 \text{ in (270 mm)} + 10.28 \text{ in (261 mm)} \pm 0.12 \text{ in (3 mm)}$   
 $L2 = N \times 10.63 \text{ in (270 mm)} + 10.63 \text{ in (270 mm)} + 10 \text{ in (254 mm)} \pm 0.12 \text{ in (3 mm)}$

Note: N is the number of SigenStor BATs and  $N \leq 2$ .

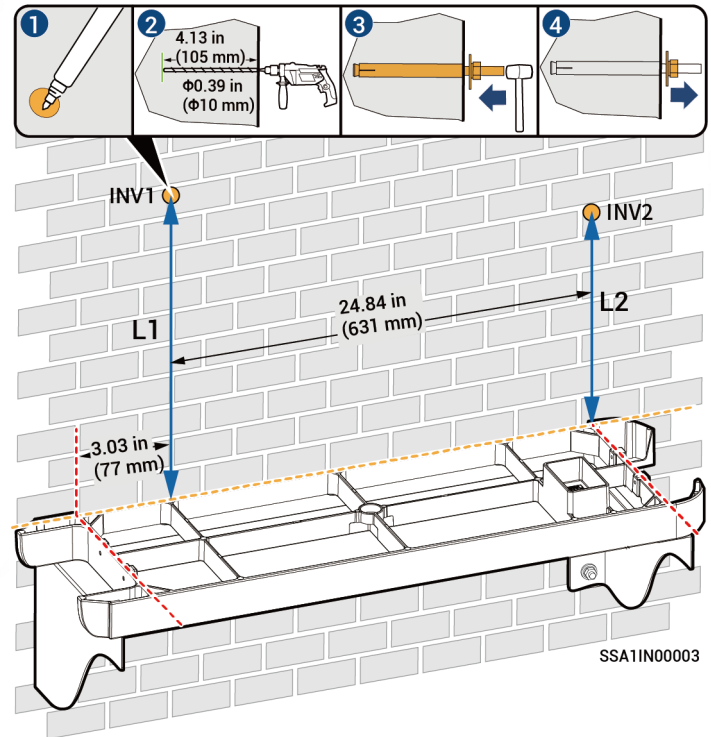

## Floor Mounting

### Tips

- You do not have to mount the inverter to the wall when there are one SigenStor BAT.
- INV1 is the mounting hole on the left side of the inverter for wall installation, while INV2 is the mounting hole on the right side for wall installation.

### Calculation formula for punch height

L1 and L2 should be measured from the upper surface of the base:  
 $L1 = N \times 10.63 \text{ in (270 mm)} + 10.63 \text{ in (270 mm)} + 10.28 \text{ in (261 mm)} \pm 0.12 \text{ in (3 mm)}$   
 $L2 = N \times 10.63 \text{ in (270 mm)} + 10.63 \text{ in (270 mm)} + 10 \text{ in (254 mm)} \pm 0.12 \text{ in (3 mm)}$

Note: N is the number of SigenStor BATs and N ranges from 2 to 5.

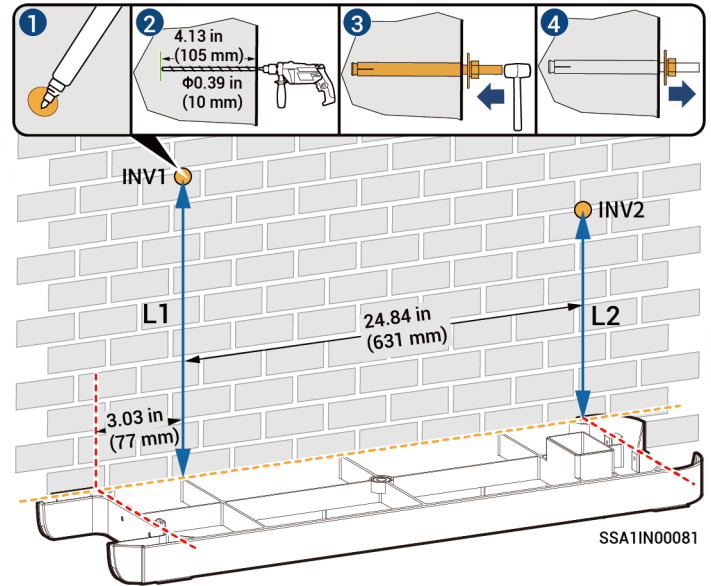

**2** Install the SigenStor EVDC.

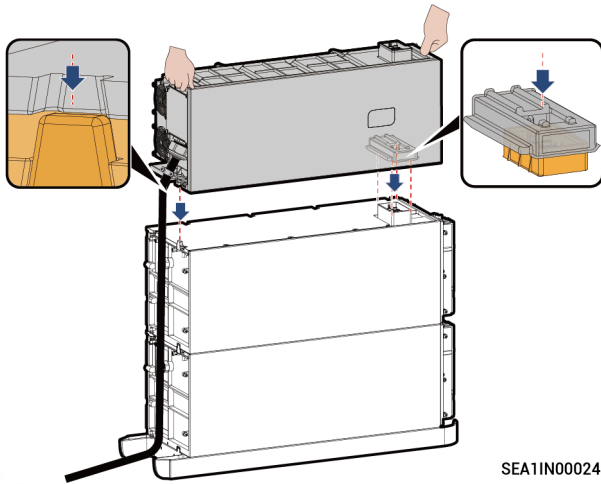

SEA11N00024

**3** Install the inverter.

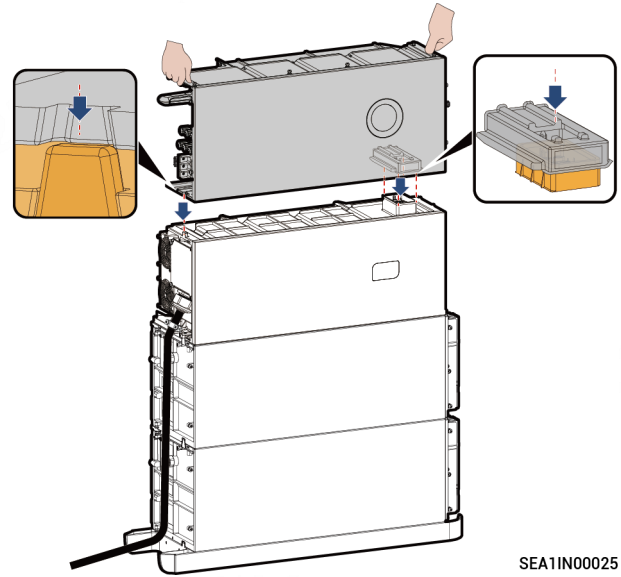

SEA11N00025

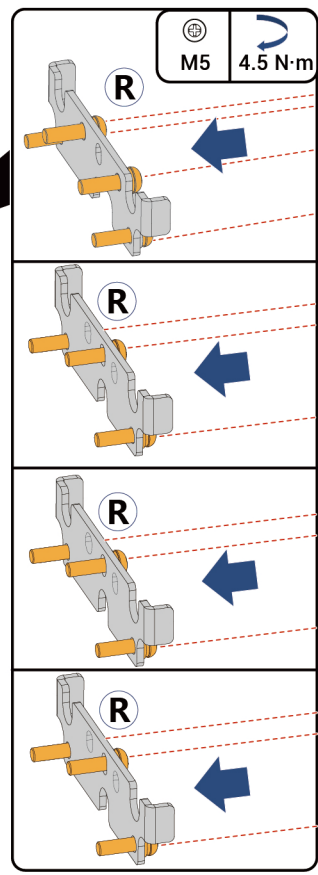
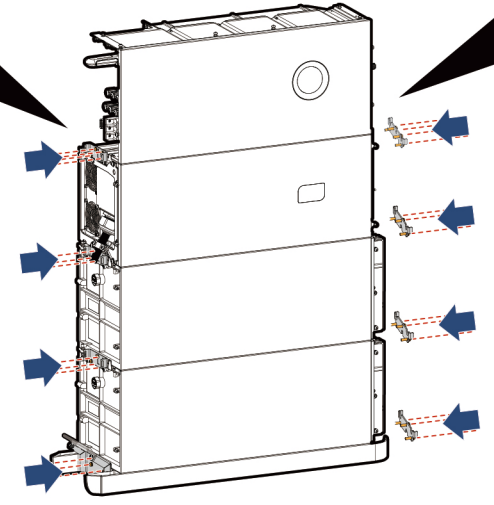
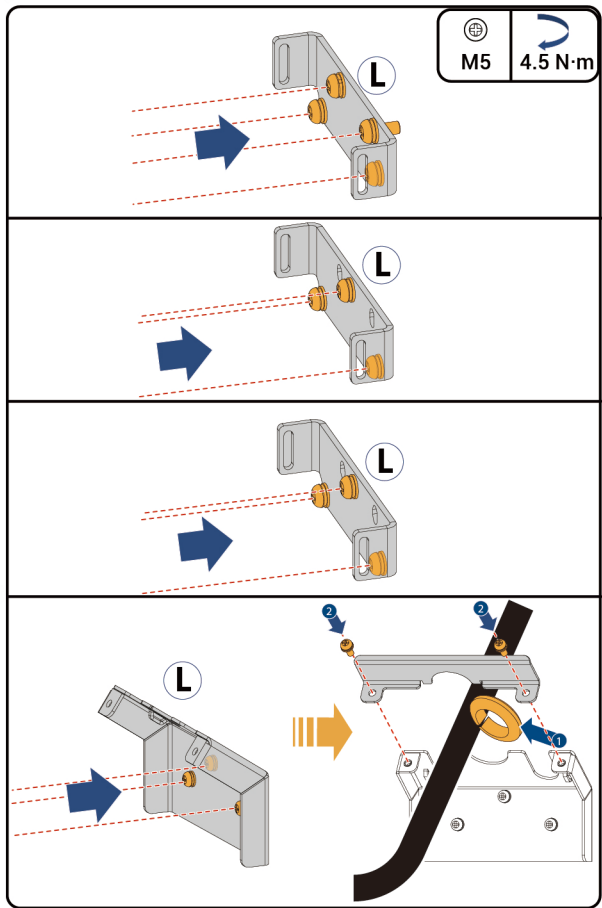

5

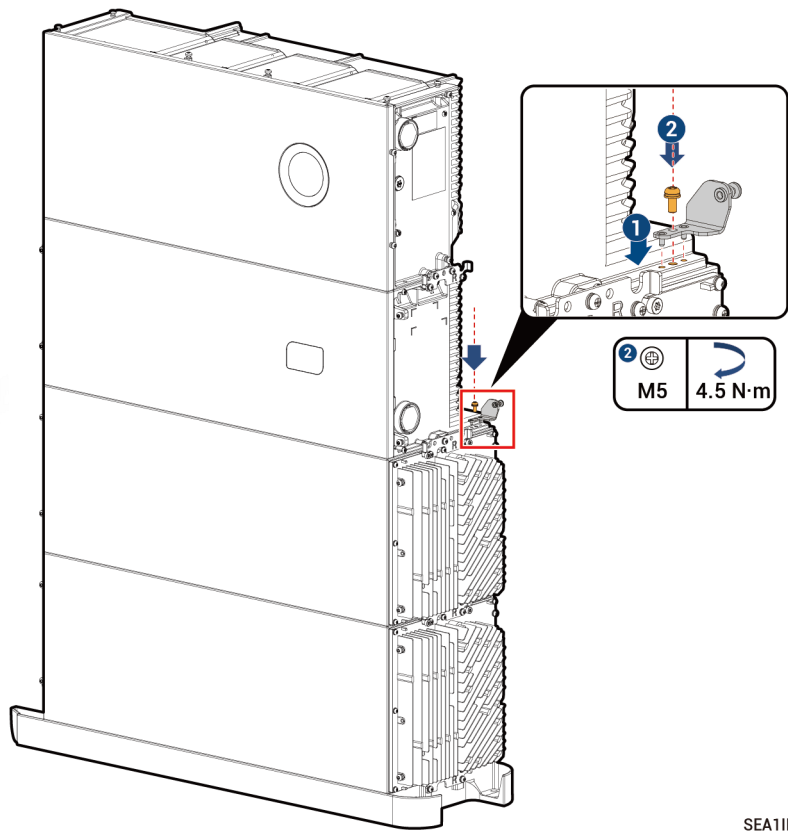

SEA1IN00058

**6** (Optional) Follow these steps to mount the inverter to the wall securely.

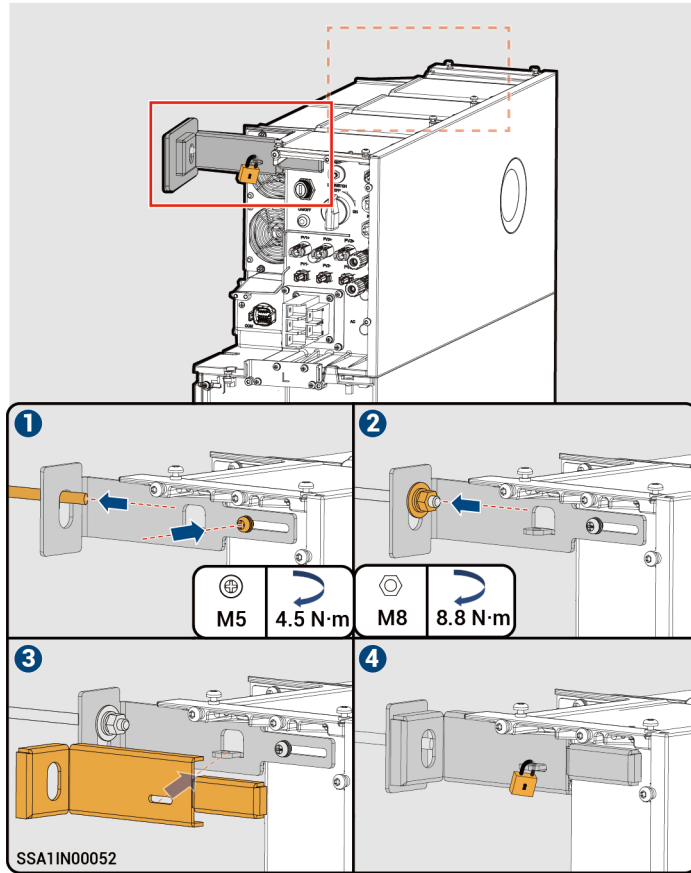

## Tips

Before installing the decorative components, please ensure the inverter cable is securely and properly connected. Please refer to the corresponding model's SigenStor Home Installation Guide for specific wiring operation procedures of the inverter.

## Caution

- The decorative cover used in step 1 is supplied with the SigenStor EVDC.
- If the strip light shows abnormal status when the equipment is powered on, check if the pins in the male connector is tilted. If tilted, straighten them out and then reconnect the corresponding male and female connectors, or reconnect the terminal in step 6 to resume normal operation.

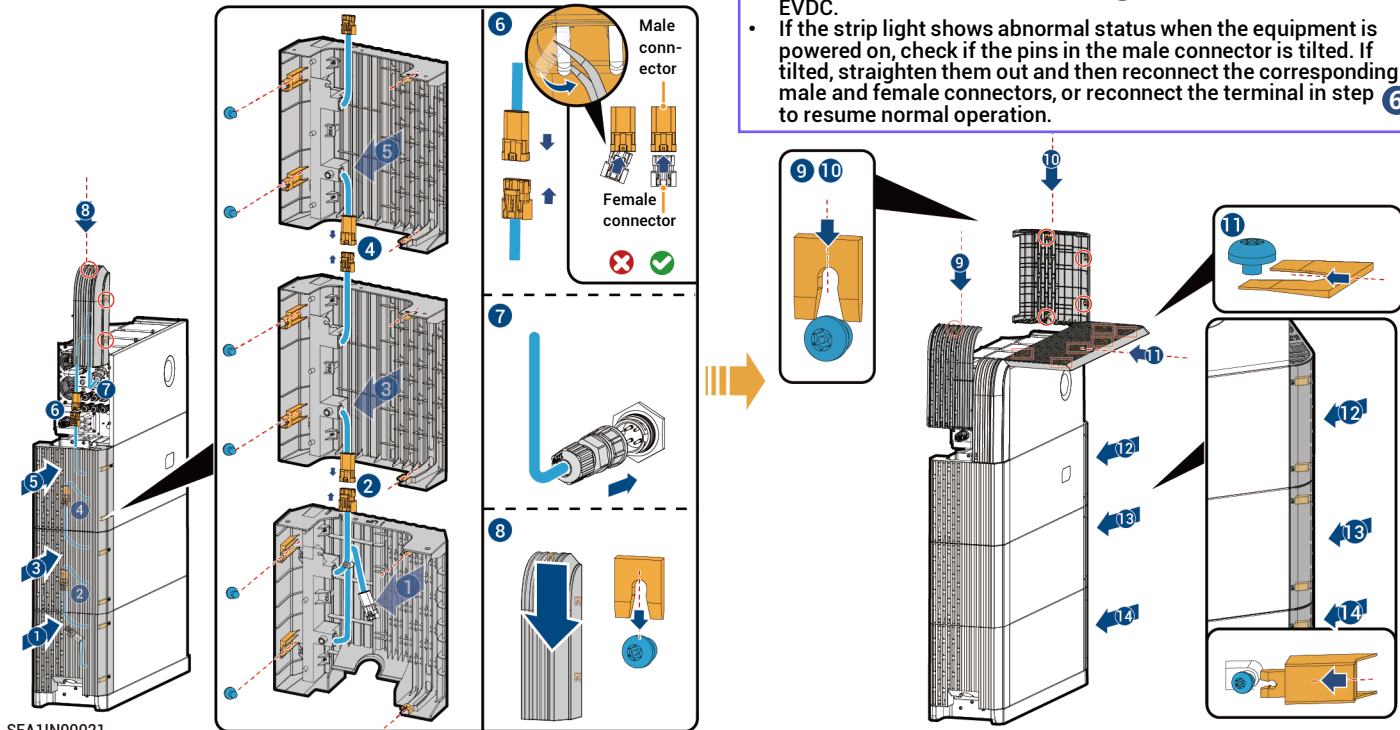

## 4.2 Inverter + SigenStor EVDC

### 4.2.1 Adding SigenStor EVDC

#### **Danger**

Do not perform operations on the equipment with power on. Always cut off the power supply before operation.

#### **Tips**

Users can add the SigenStor EVDC to the Sigen Hybrid series inverters.

- 1** Remove the cable connected to the inverter and remove the inverter.

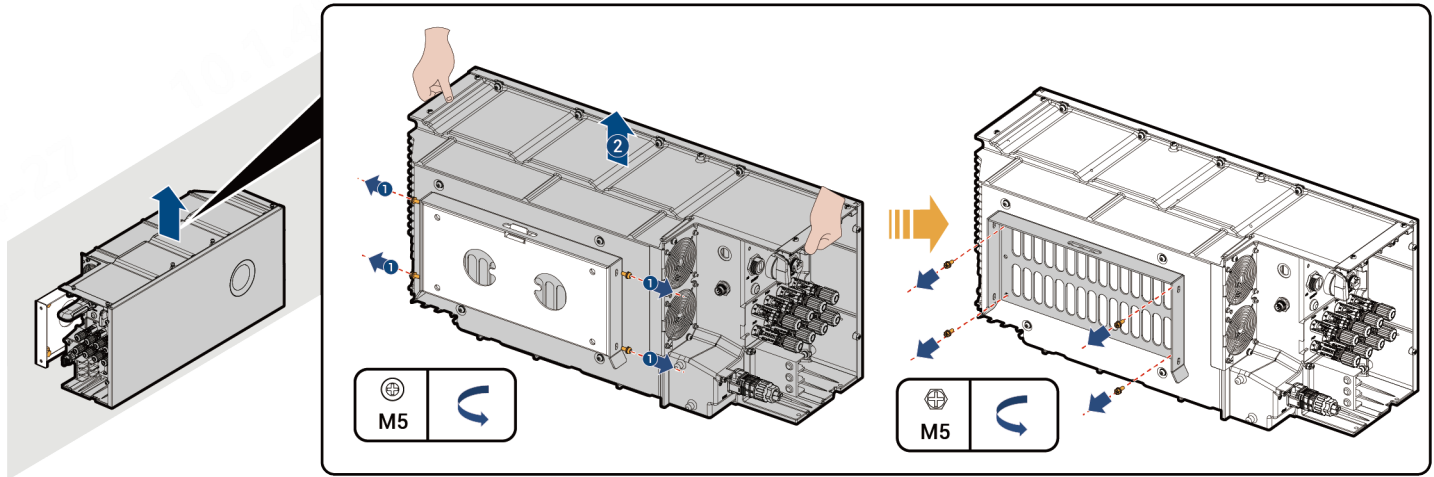

SEA11N00022

2

## Danger

Please follow the operation steps hereby precisely. If this step is not followed, there may be high voltage on the equipment after the equipment is powered on, and touching Position 1 as shown in the figure will cause personal injury.

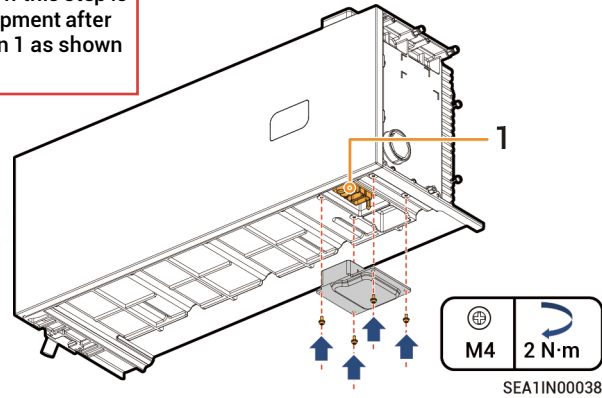

3

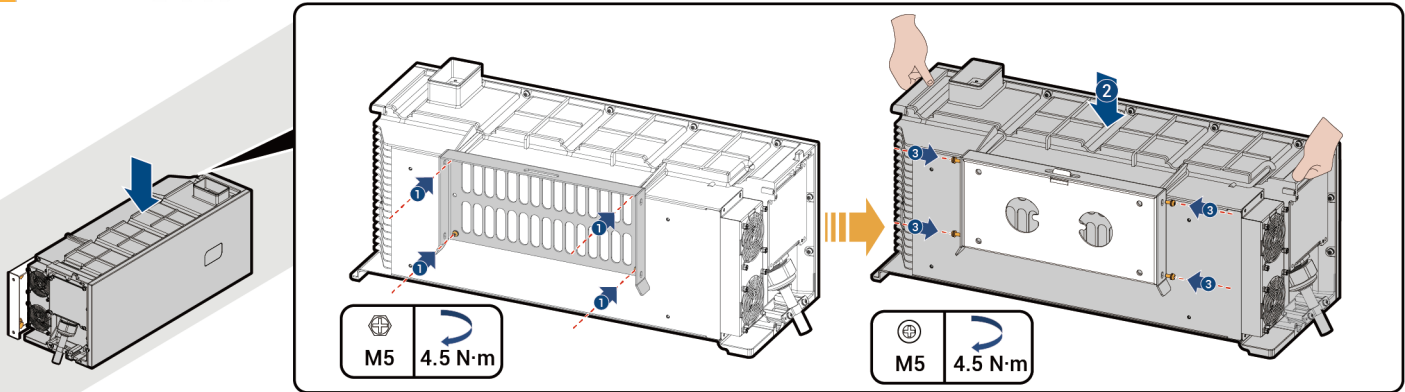

4

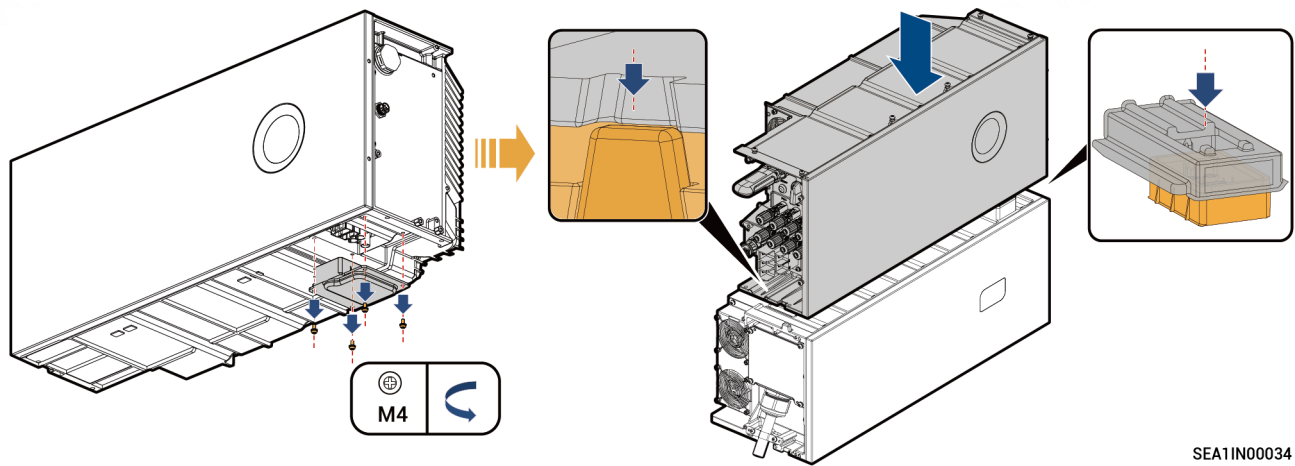

SEA1IN00034

5

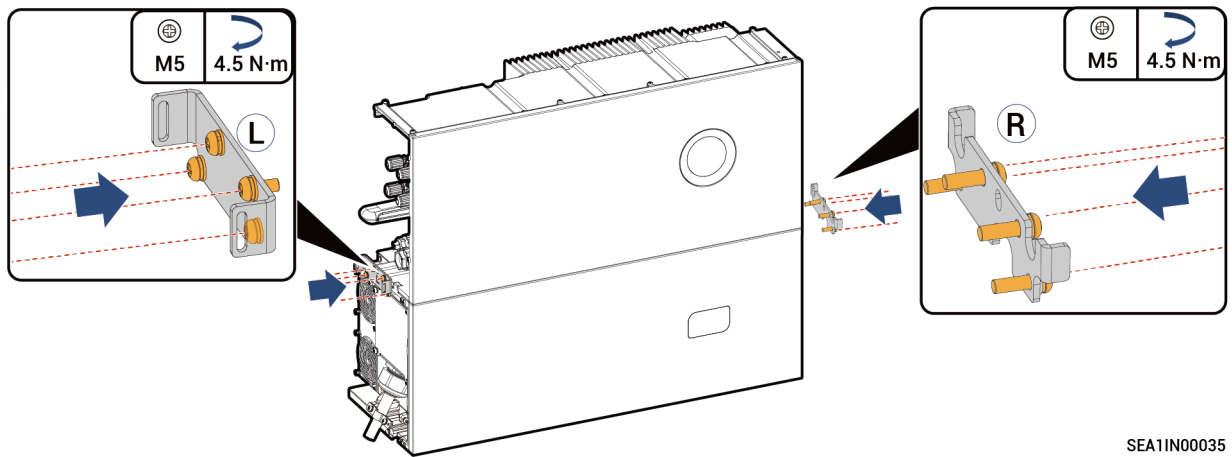

SEA1IN00035

**6** Reinstall the inverter cable.

## Tips

Please refer to the corresponding model's Installation Guide for specific installation procedures.

## 4.2.2 Newly Installing All Components

1

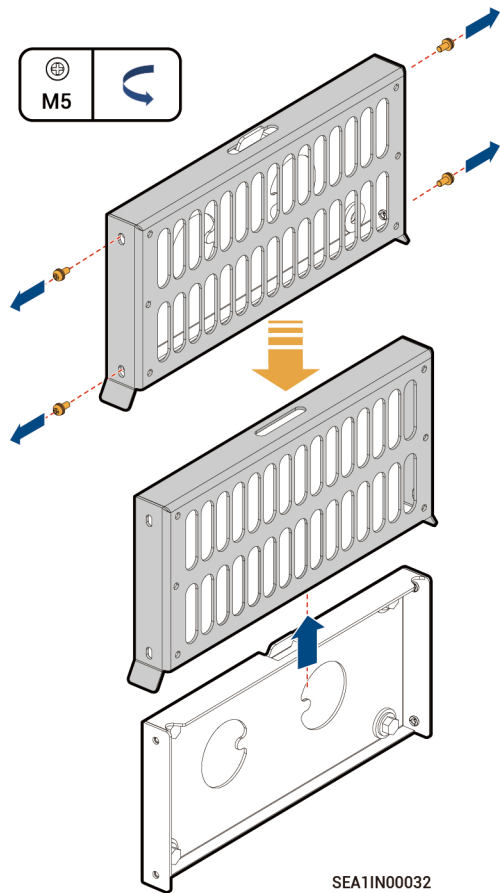

2

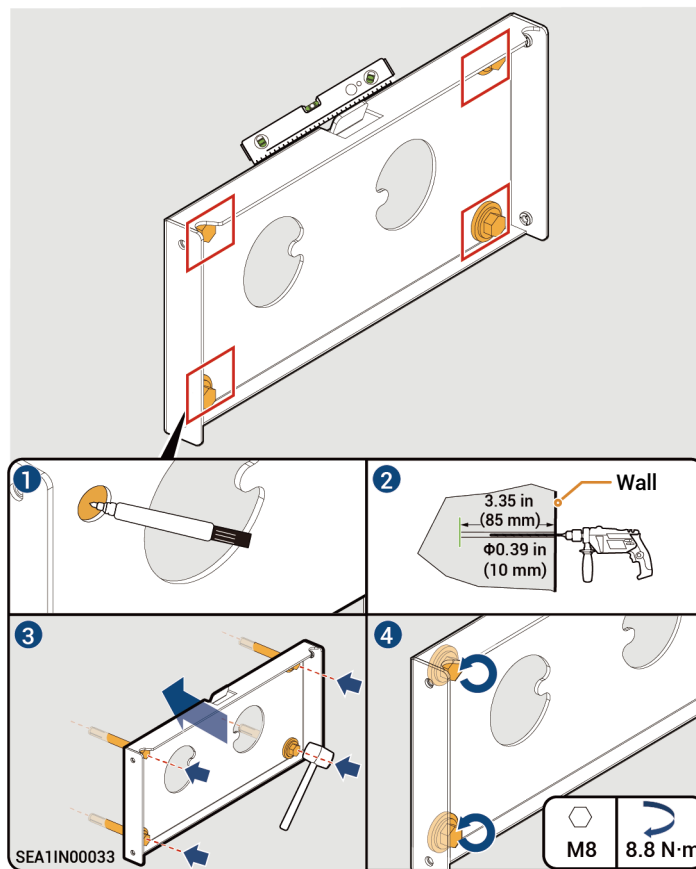

3

**Danger**

Please follow the operation steps hereby precisely. If this step is not followed, there may be high voltage on the equipment after the equipment is powered on, and touching Position 1 as shown in the figure will cause personal injury.

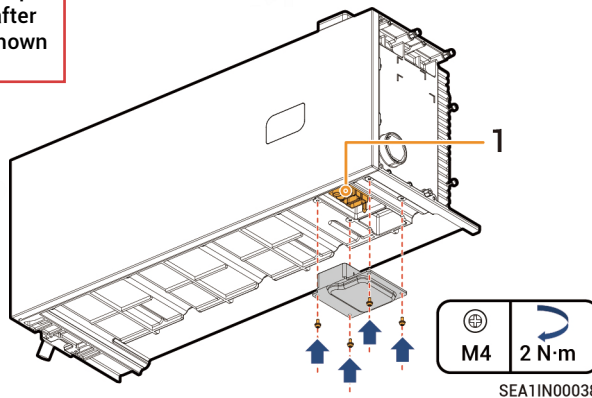

4

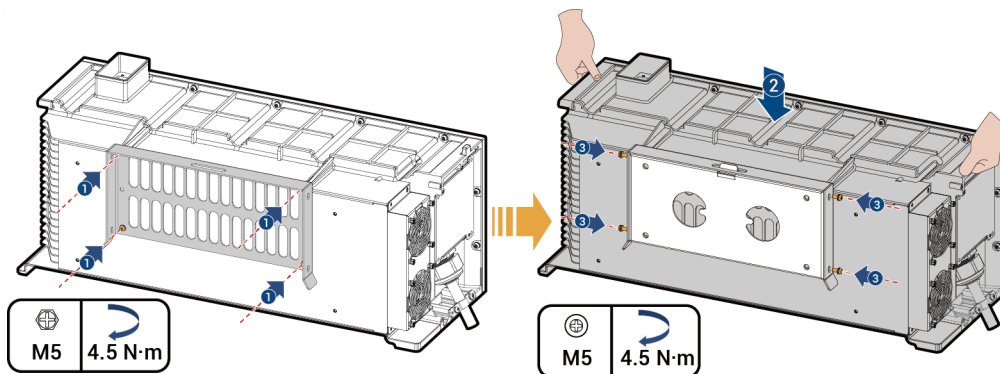

5

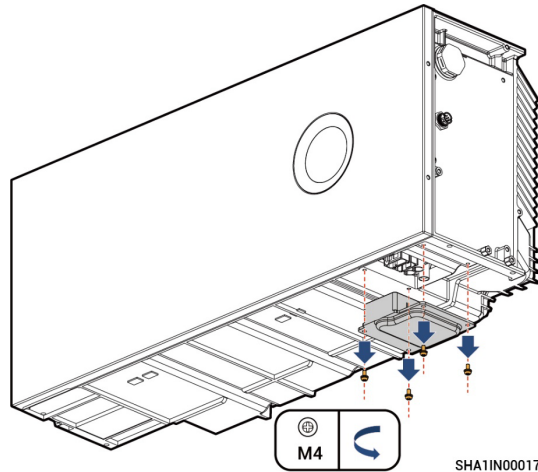

6

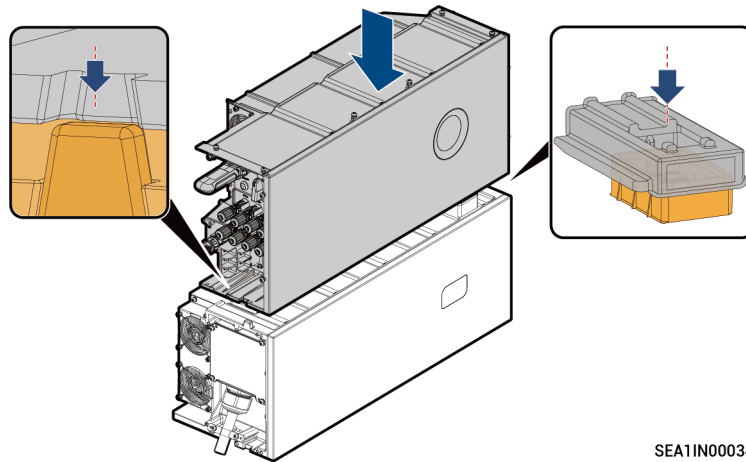

7

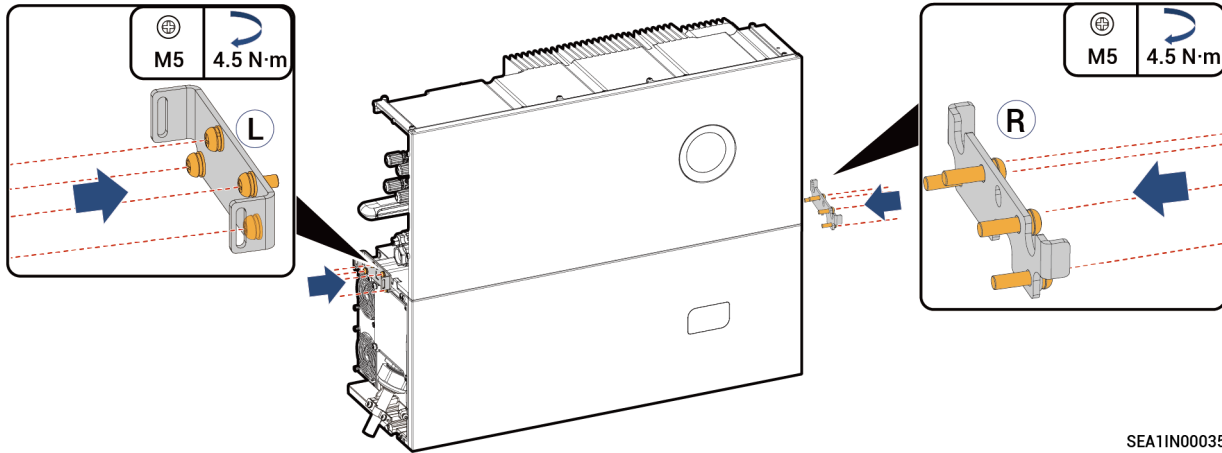

SEA11N00035

8 Connect the inverter cable.

## Tips

Please refer to the corresponding model's Installation Guide for inverter details.

## 5 Installation of Charging Socket and Placement of Charging Connector

SigenStor EVDC 12 (5S2, 7.5S2, 10S2)  
SigenStor EVDC 25 (5S2, 7.5S2, 10S2)

1

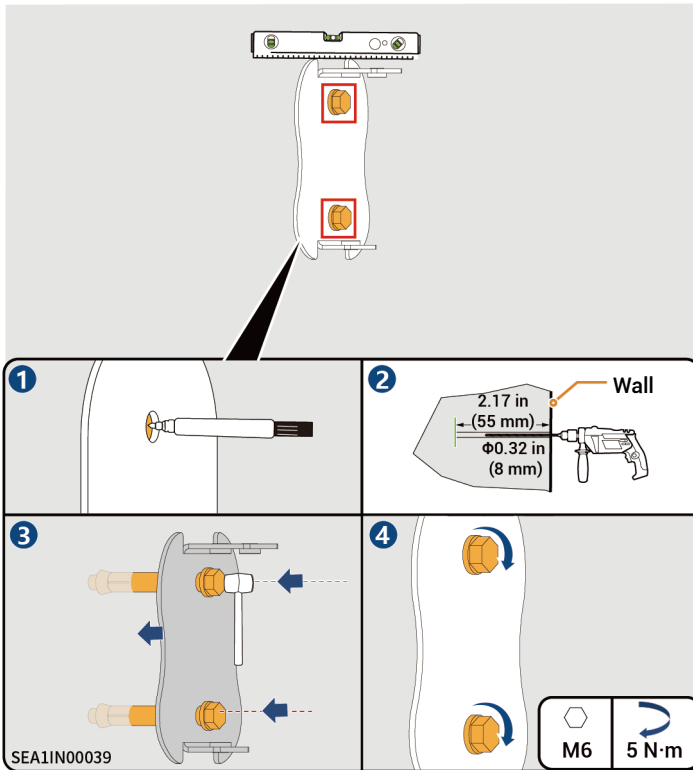

2

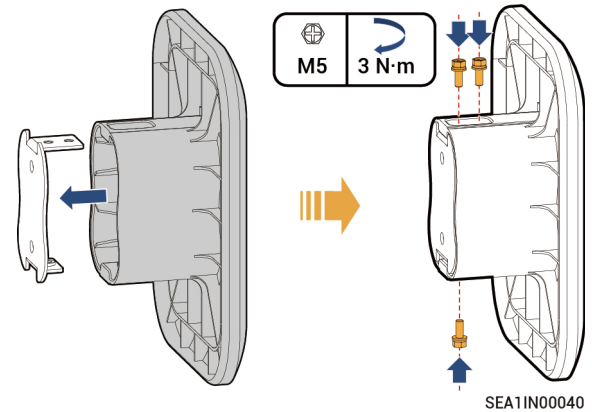

3

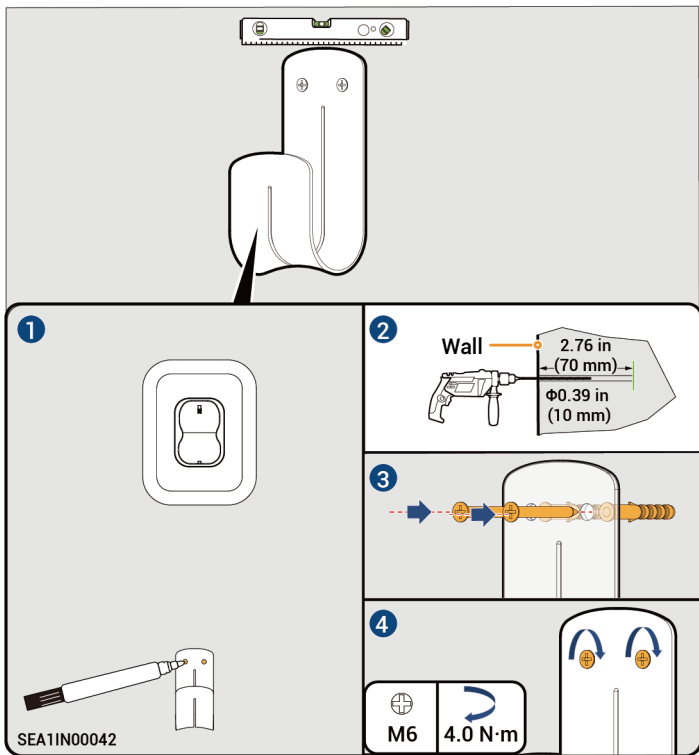

4

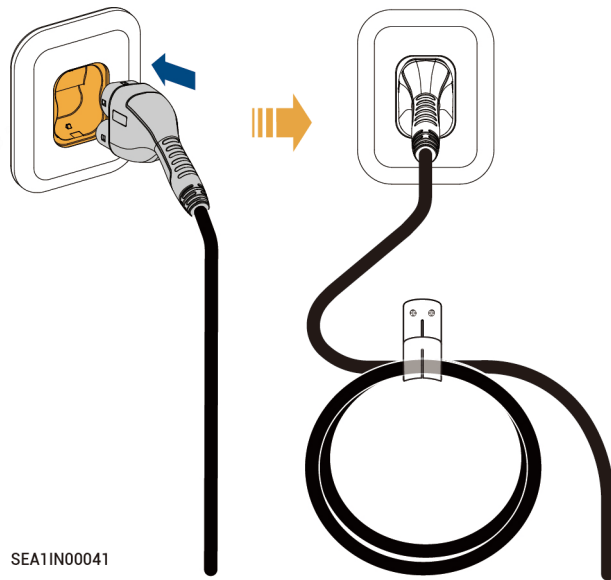

SigenStor EVDC 12 (7.5GBT, 10GBT)  
 SigenStor EVDC 25 (7.5GBT, 10GBT)

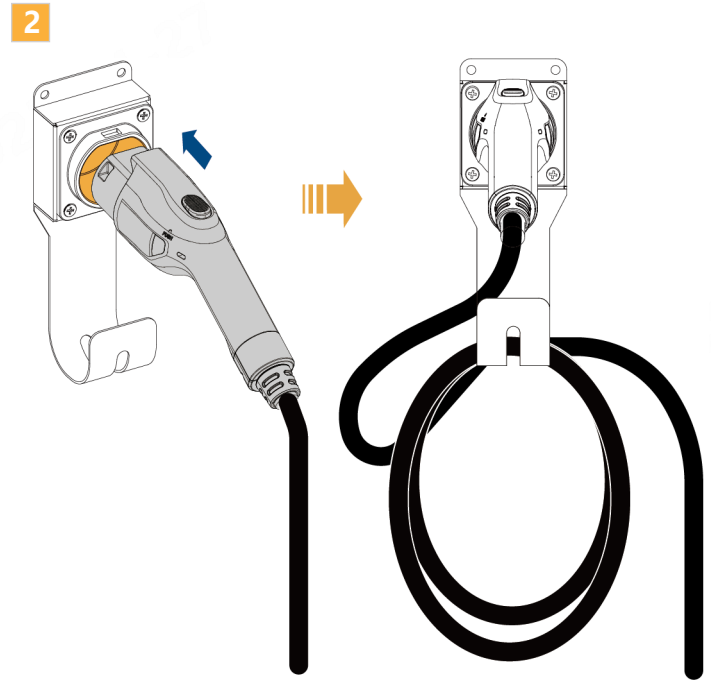
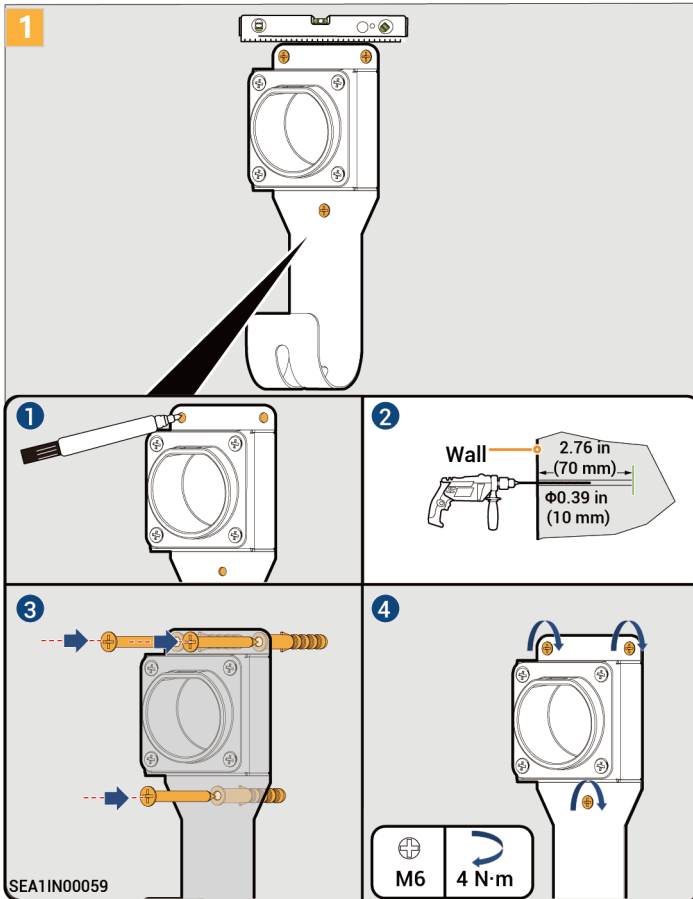

## 6 Power On

1. Turn on the upstream switch of equipment.
2. Turn the "DC SWITCH" of the inverter to the "ON" position. (This step is not necessary for SigenStor AC)
3. View indicator status on the front panel of the SigenStor EC/SigenStor AC/Sigen Hybrid to check the operation status of the equipment.

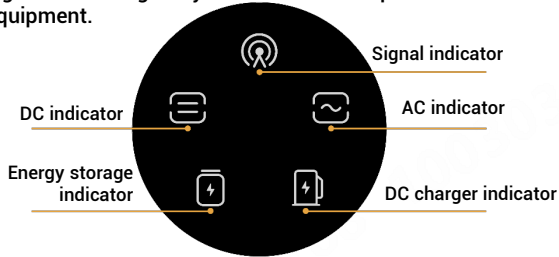

Indicator	Color	Status	Status of SigenStor EVDC
		Off	Not powered on.
		Steady on	Powered on but the charging connector not connected to the vehicle.
		Steady on	<ul style="list-style-type: none"> <li>The charging connector connected to the vehicle.</li> <li>Charging completed.</li> </ul>
		Blink quickly	Charging starts, and the equipment is ready for charging <sup>[Note]</sup> .
		Blink	Charging.
		Steady on	Alarming.
		Steady on	Equipment failure.

**Note:** After the user starts charging by swiping the card, setting the App, or bypassing authentication, wait for more than 30 s until a "beep" sound gives out. The equipment starts charging. If the user or vehicle actively stops charging or the equipment is malfunctioning during the wait period and four "beep" sounds give out, the charging process stops prematurely.

## 7 Creating a New System

- 1 Please visit <https://www.sigenergy.com> and go to "Partner" → "Register Now" and sign up for your account.
- 2 Download the mySigen app to initiate the creation of a new system for your equipment.



## Creating New Systems in Both SigenStor EVDC and Other Devices

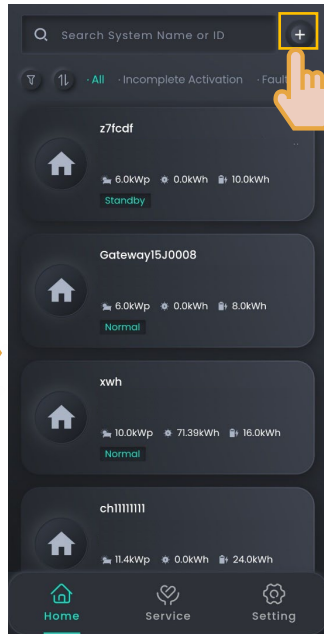
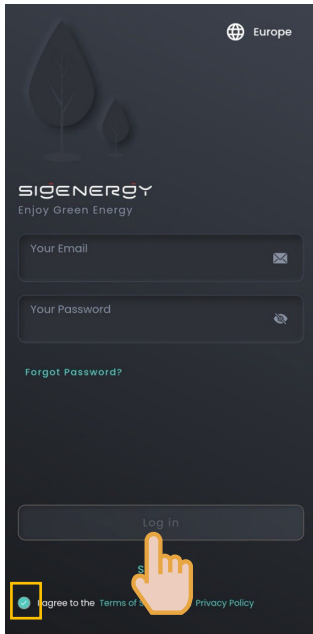

- Create a new system as instructed on the screen.
- Please refer to the mySigen App Creating New Systems Guide for operation procedures.



## Adding SigenStor EVDC to an Existing Power Station

The application system will automatically identify and add devices without manual operation.

■ FAQ

How to remove and install the charging connector cable of the SigenStor EVDC?

Remove the charging connector cable

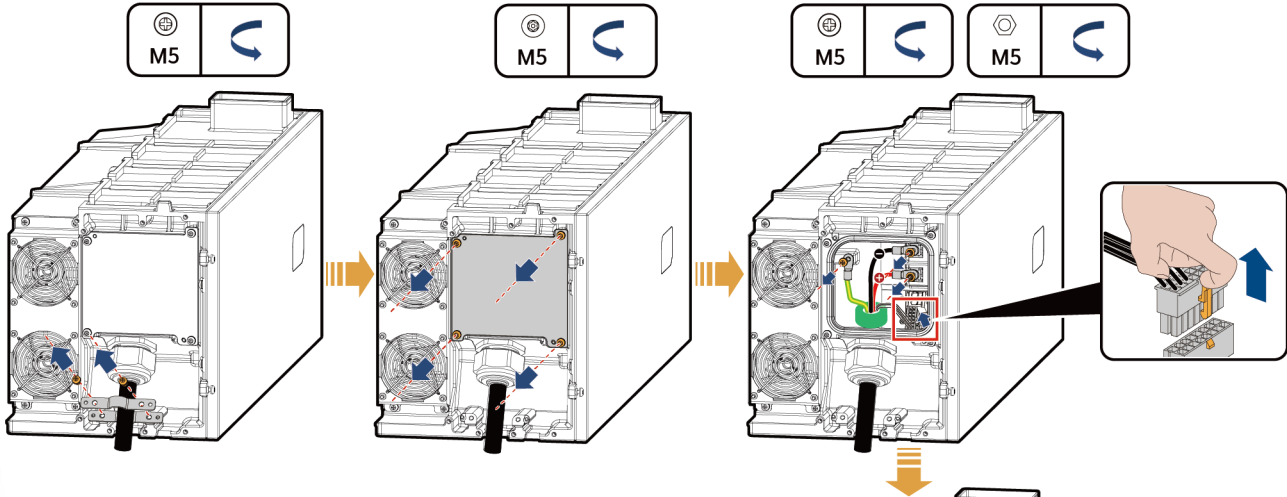

After removing the charging connector cable, do not damage the cable label.

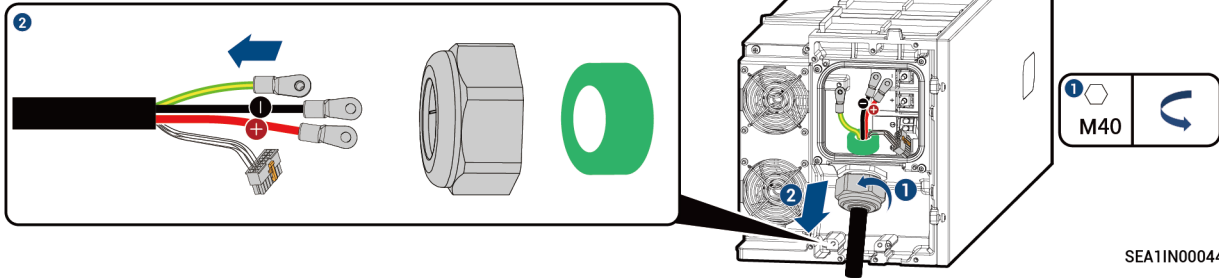

SEA1IN00044

## Install the charging connector cable

### Caution

Please make sure that the cable is properly connected and the screws are tightened to prevent equipment damage.

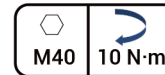
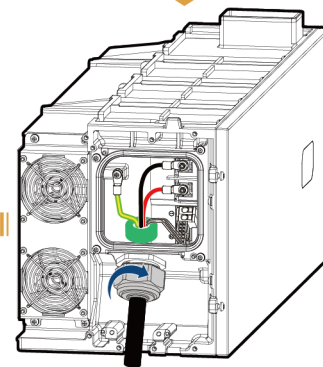
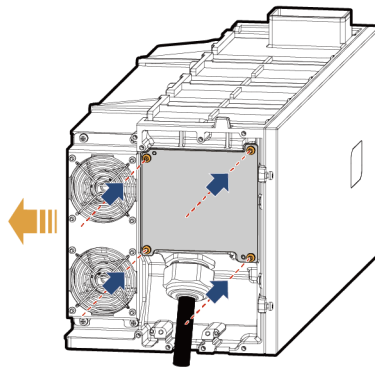
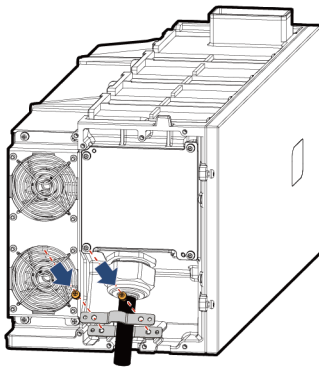
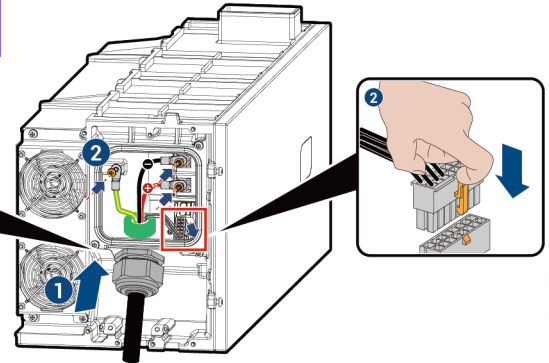
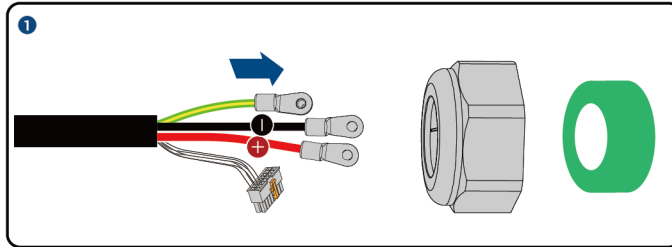

SEA11N00045

## How to upgrade SigenStor EVDC from 12 kW to 25 kW?

**1** Purchase and activate the license. For details, see chapters “How to Buy Extended Warranty Service” and “How to Activate a License?” in the mySigen APP Installer Manual or the mySigen App User Manual.



**2** Carry out the following operations with the attached nameplates.

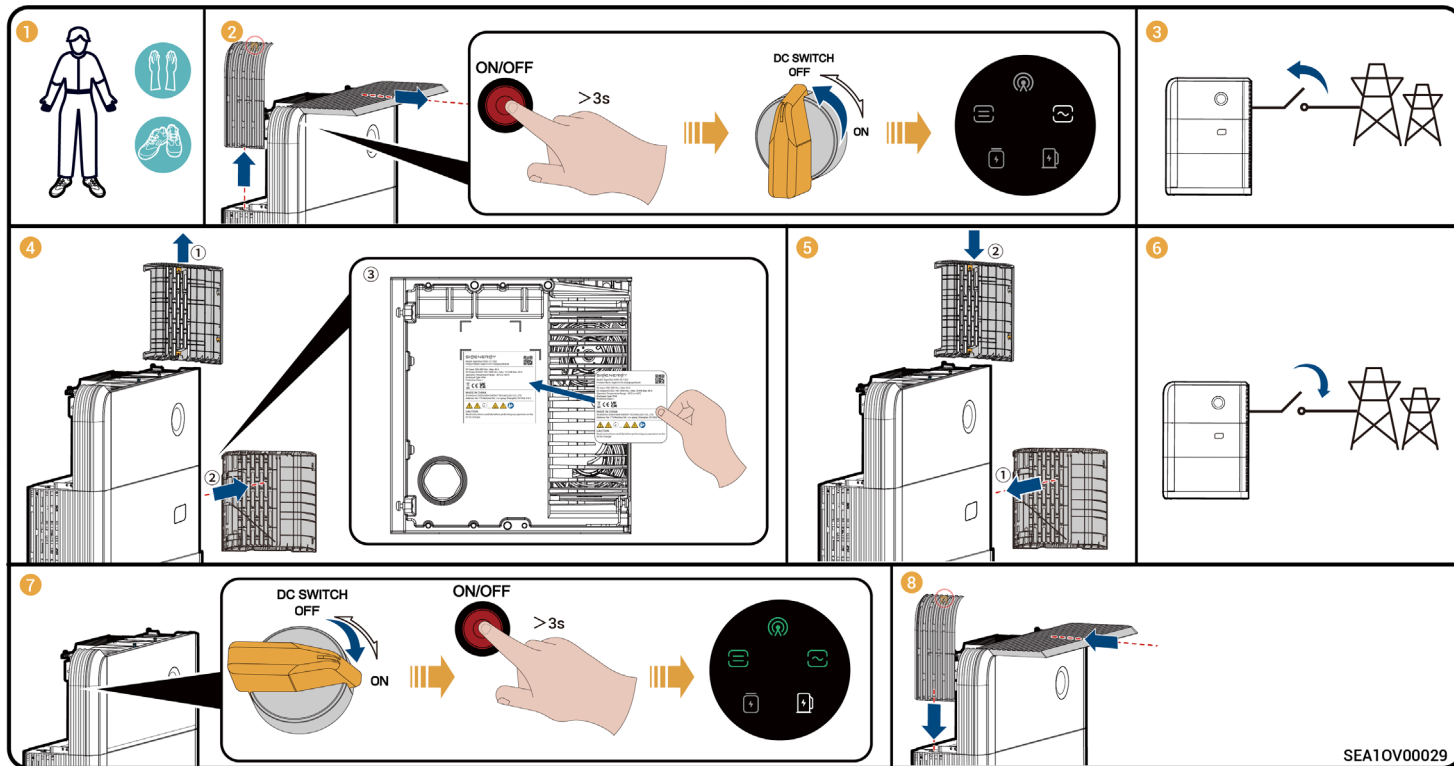

SEA10V00029

**Sigenergy Technology Co., Ltd.**



Website	LinkedIn	YouTube
---------	----------	---------

**[www.sigenergy.com](http://www.sigenergy.com)**



**Copyright © Sigenergy Technology Co., Ltd. 2025. All rights reserved.**

Description in this document may contain predictive statements regarding financial and operating results, product portfolio, new technology, configurations and features of product. Several factors could cause difference between actual results and those expressed or implied in the predictive statements. Therefore, description in this document is provided for reference purpose only and constitutes neither an offer nor an acceptance. Sigenergy Technology Co., Ltd. may change the information at any time without notice.