

Assembly instructions

# SpeedRail System



# Content

▶ Tools overview	3
▶ General safety information	4
▶ Guidelines	5
▶ Components: Portrait assembly	6
▶ Components: Landscape assembly	8
▶ Assembly	10
▶ Alternative system assemblies	15
▶ Notes	18

## quality Tested – multiple certifications

K2 Systems stands for secure connections, highest quality and precision. Our customers and business partners have known that for a long time. Independent institutes have tested, confirmed and certified our capabilities and components.



Please find our quality and product certificates under:  
[www.k2-systems.com/en/technical-information](http://www.k2-systems.com/en/technical-information)

The SpeedRail system SpeedRail/SpeedClip has the German general building authority technical approval Z-14.4-603.

### Übereinstimmungszeichen (Ü-Zeichen)



# Tools overview

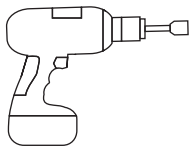

6 mm



8 mm



25



6-30 Nm  
(4,5-22,2 lb-ft)



6 mm

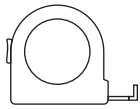

≥3,0m



≥6,0m

# General safety information

Please note that our general mounting instructions must be followed at all times and can be viewed online at [www.k2-systems.com/en/technical-information](http://www.k2-systems.com/en/technical-information)

- ▶ The equipment may only be installed and operated by qualified and adequately trained installers.
- ▶ Prior to installation, ensure that the product complies with on-site static loading requirements. For roof-mounted systems, the roof load-bearing capacity must always be checked.
- ▶ National and local building regulations and environmental requirements must be adhered to.
- ▶ Compliance with health and safety regulations, accident prevention guidelines and applicable standards is required.
  - Protective equipment such as safety helmet, boots and gloves must be worn.
  - Roofing works must be in accordance with roofing regulations utilising fall protection safeguards when eaves height exceeds 3 m.
  - At least two people must be present for the duration of the installation work in order to provide rapid assistance in the event of an emergency.
- ▶ K2 mounting systems are continuously developed and improved and the installation process may thereby change at any time. Prior to installation consult our website at [www.k2-systems.com/en/technical-information](http://www.k2-systems.com/en/technical-information) for up-to-date instructions. We can send you the latest version on request.
- ▶ The assembly instructions of the module manufacturer must be adhered to.
- ▶ Equipotential bonding/grounding/earthing between individual parts is to be performed according to country specific standards, as well as national laws and regulations.
- ▶ At least one copy of the assembly instructions should be available on site throughout the duration of the installation.
- ▶ Failure to adhere to our general safety and assembly instructions and not using all system components, K2 is not liable for any resulting defects or damages. We do not accept liability for any damage resulting in the use of competitor's parts. Warranty is excluded in such cases.
- ▶ German law shall apply excluding the UN Convention on CISG. Place of venue is Stuttgart. Our General Terms of Business apply.
- ▶ If all safety instructions are adhered to and the system is correctly installed, there is a product warranty entitlement of 12 years! We strongly recommend reviewing our terms of guarantee, which can be viewed at [www.k2-systems.com/en/technical-information](http://www.k2-systems.com/en/technical-information) We will also send this information on request.
- ▶ Dismantling of the system is performed in reverse order to the assembly.
- ▶ K2 stainless steel components are available in different corrosion resistance classes. Each structure or component must be carefully checked for possible corrosion exposure.

# The following guidelines apply

The SpeedRail system can be used without further testing by K2 systems in the following standard conditions. The system is also suitable for higher requirements. However, if a value exceeds the standard conditions, please contact K2 Systems.



## Roof requirements

- ▶ Sheet thickness: Aluminium  $\geq 0.5$  mm and steel  $\geq 0.4$  mm
- ▶ Minimum tensile strength for aluminium:  $165 \text{ N/mm}^2$ ; steel grade minimum S235
- ▶ Minimum 22 mm crest width
- ▶ Roof pitch inclination: 5-75°



## Structural requirements

Sufficient holding force of the roof covering on the support or substructure



## Important mounting instructions

- ▶ Earthing must be ensured (use lightning arrestor clamp if necessary).
- ▶ If the troughed sheet is to be fastened with calottes, please never bolt the SpeedClips to the calottes! Instead of this, mount all SpeedClips staggered in this sequence on the troughed sheet.
- ▶ Mount every fourth SpeedClip rotated by 180°; see assembly step 4.
- ▶ For rail joints, SpeedClips must be attached to the nearest high crest on both sides.
- ▶ Ensure a thermal separation after 8.80 m. The minimum distance between two rails should be 3 cm.
- ▶ The modules may never be fixed over the thermal expansion joint.
- ▶ A SpeedLock per SpeedRail up to 8.80 m in total length, is required (speed rail connected via a rail connector counts as a SpeedRail).
- ▶ When laying frameless modules vertically, always build in a stopper to prevent sliding-off for each module.
- ▶ MK2 slot nuts and module clamps at butt joints of the rails must be avoided!
- ▶ A minimum mounting distance of 50 mm from the end of the rail/rail joint to the module frame.
- ▶ No pre-drilling required! Predrill only with overlapping sheets to reduce spacing.

# Components

## Portrait assembly

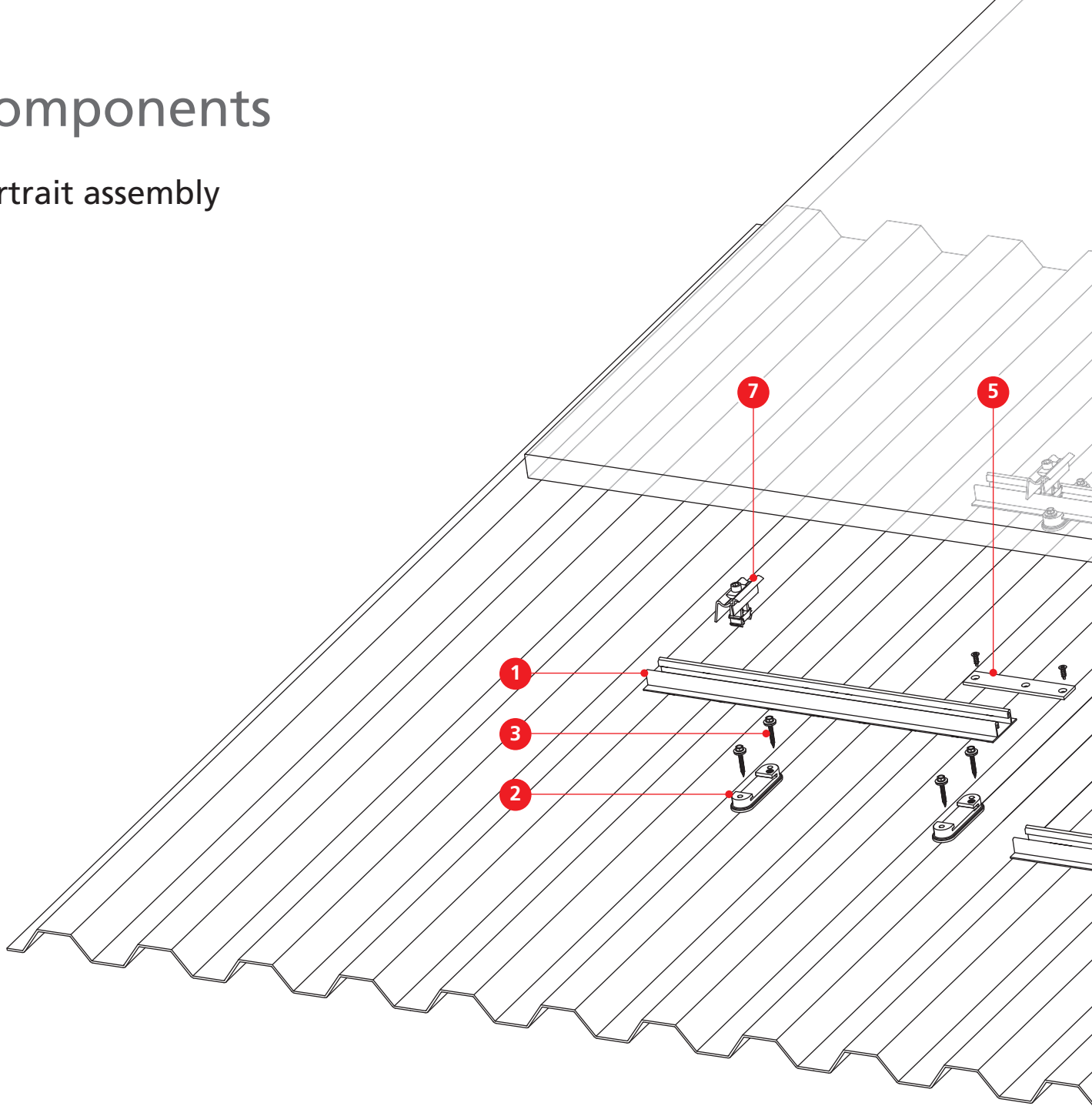

**1** Item number system-specific

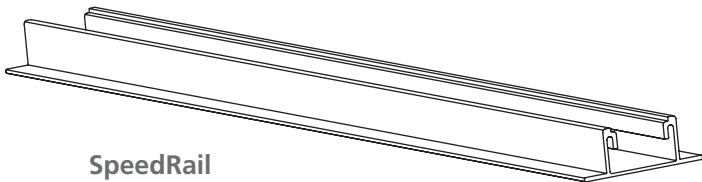

SpeedRail

**2** 1001164

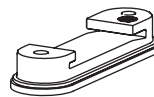

SpeedClip

**3** 1005193

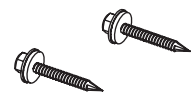

Self-tapping screws with sealing washer 6×38 mm

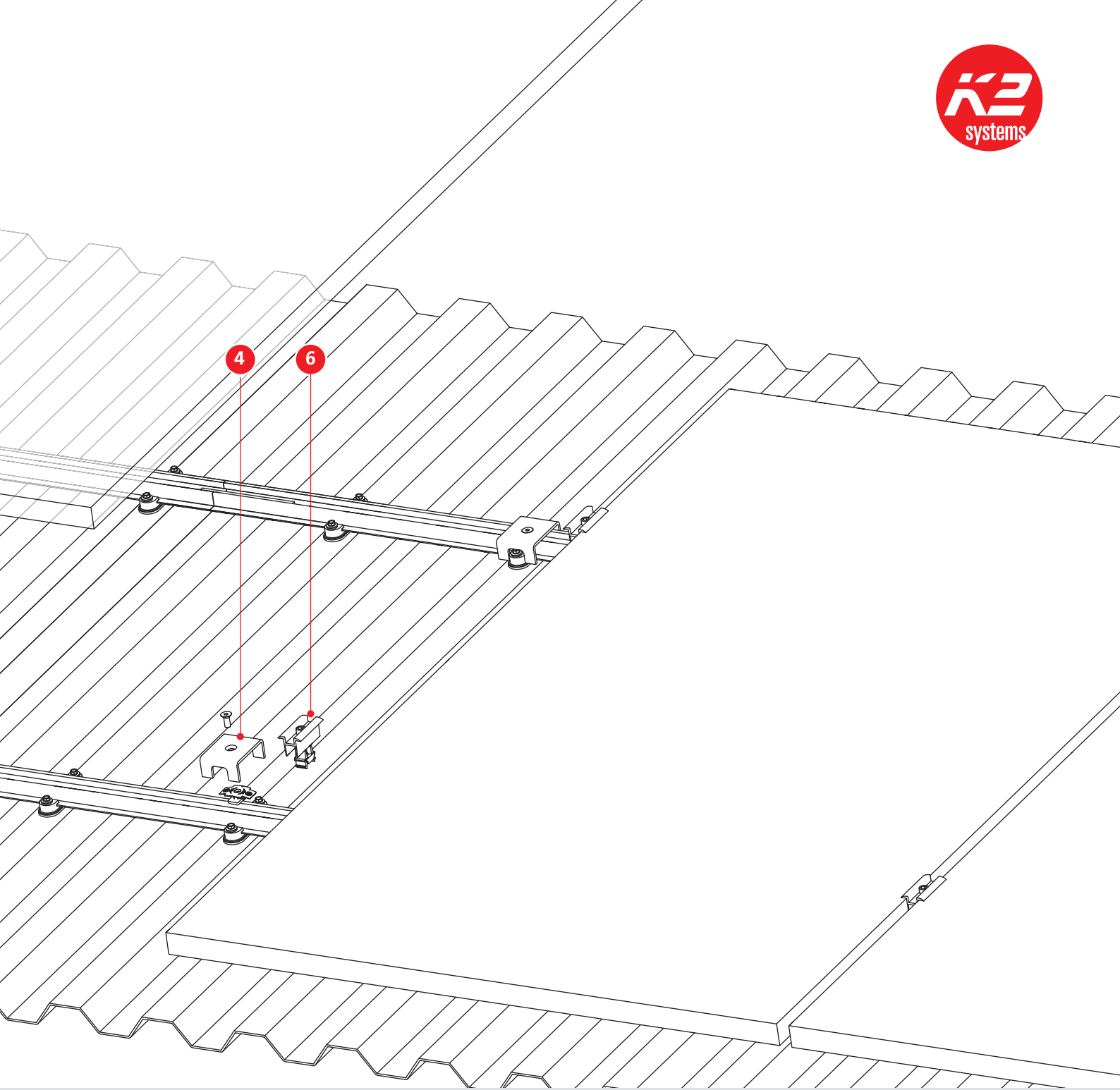

4 1003558

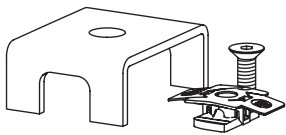

SpeedLock Set

5 1003571

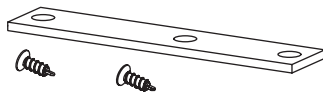

SpeedConnector Set

6 2002515 / 2002588

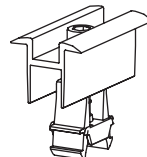

OneMid  
aluminium mill  
finish / black  
anodised

7 2002514 / 2002589

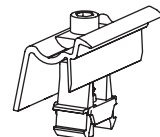

OneEnd  
aluminium mill  
finish / black  
anodised

# Components

## Landscape assembly with AddOn

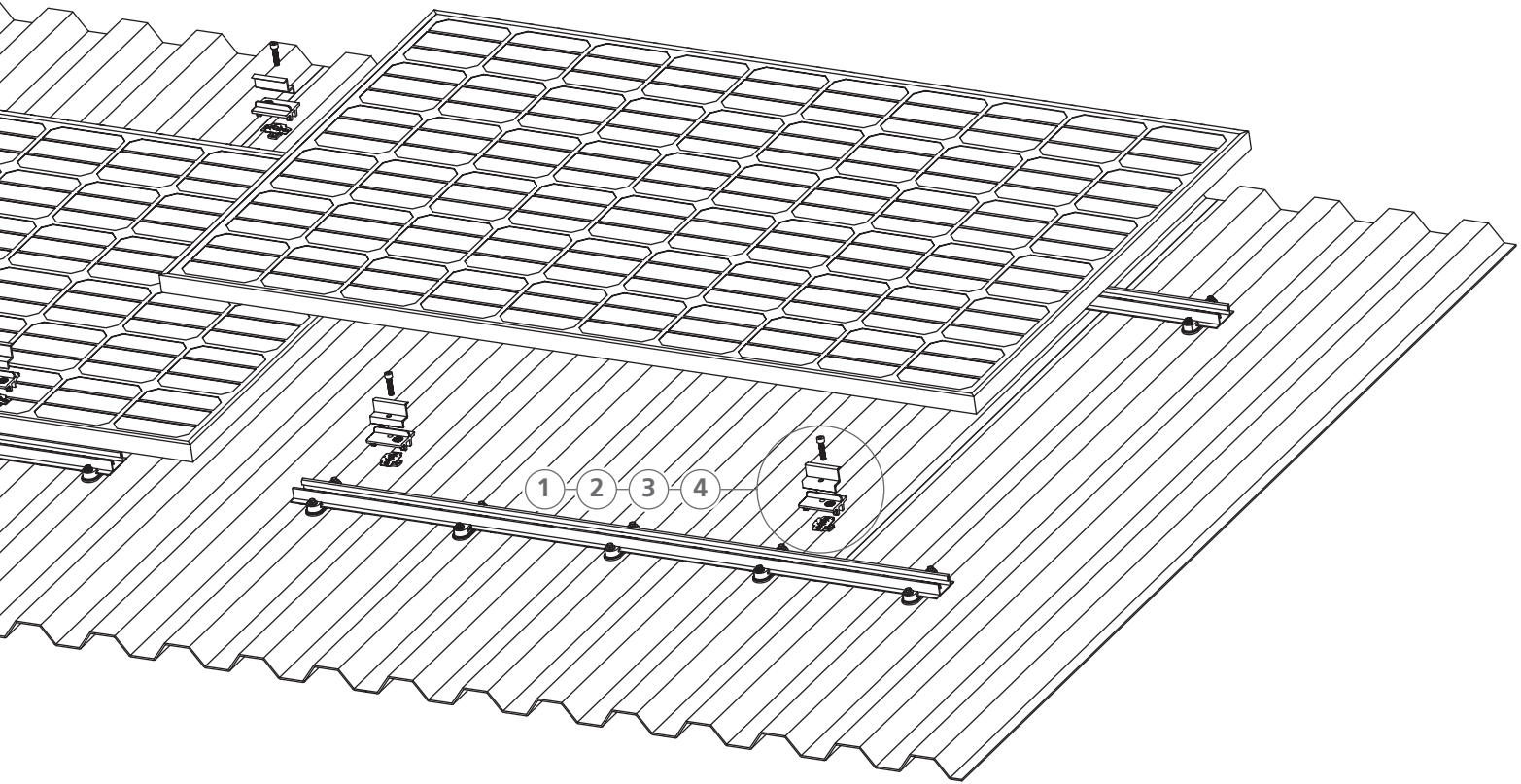

- ① Screw length module frame specific  
**socket head cap screw**
- ② End clamp and middle clamp module frame specific
- ③ 1005530 / 2001707  
**AddOn 22/30**
- ④ 1001643  
**MK2 slot nut**

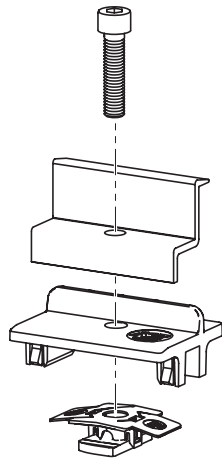

# Landscape assembly with two layers of rails

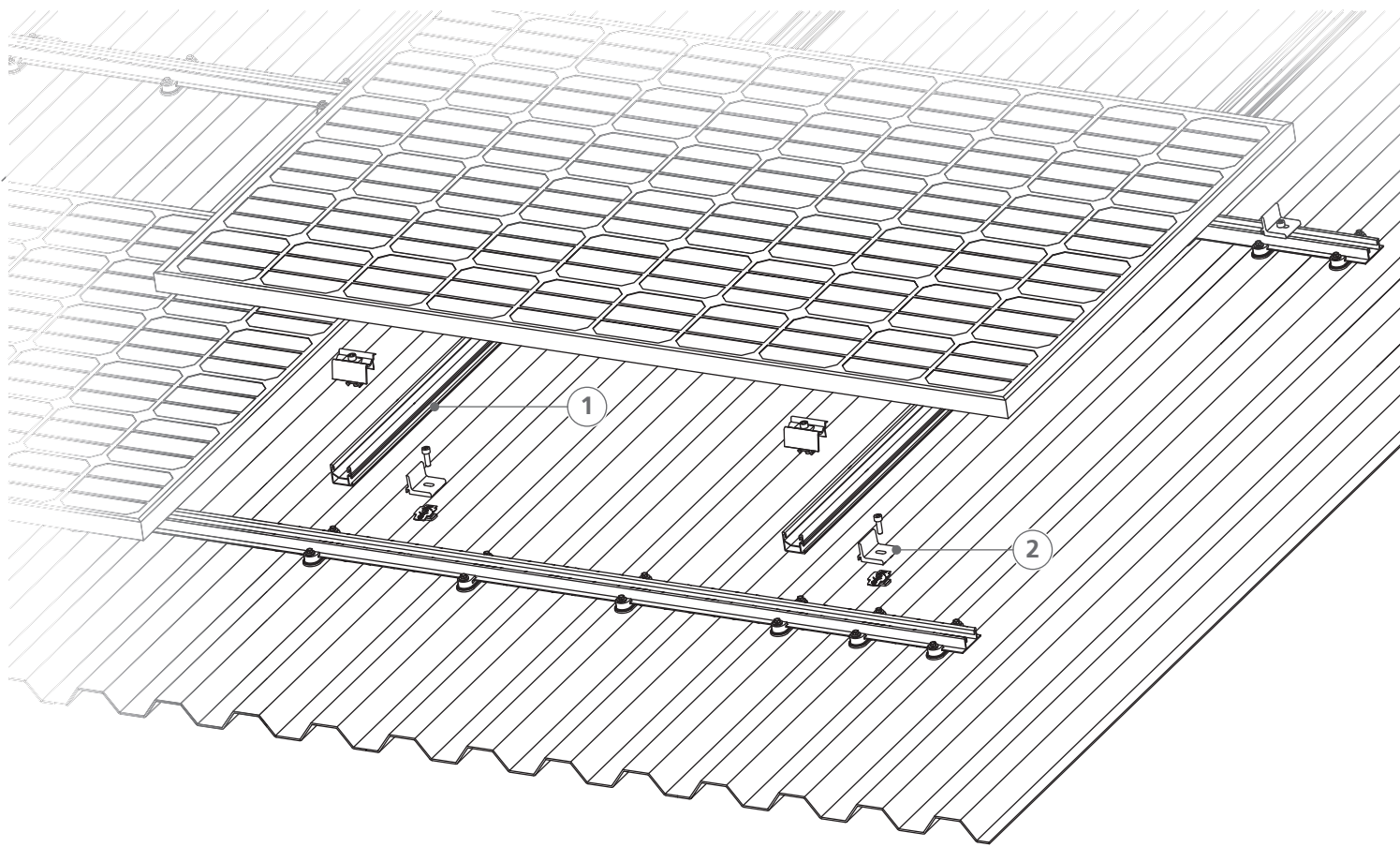

① Item number system-specific

② 1006041

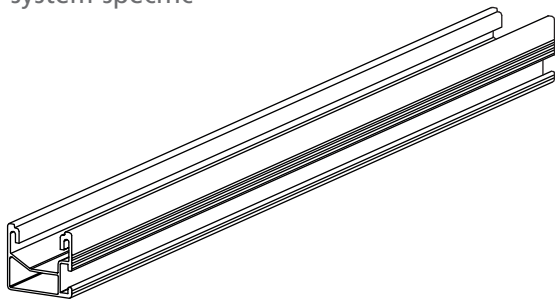

SingleRail

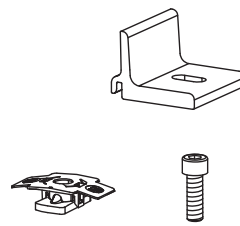

Climber Set

# Assembly

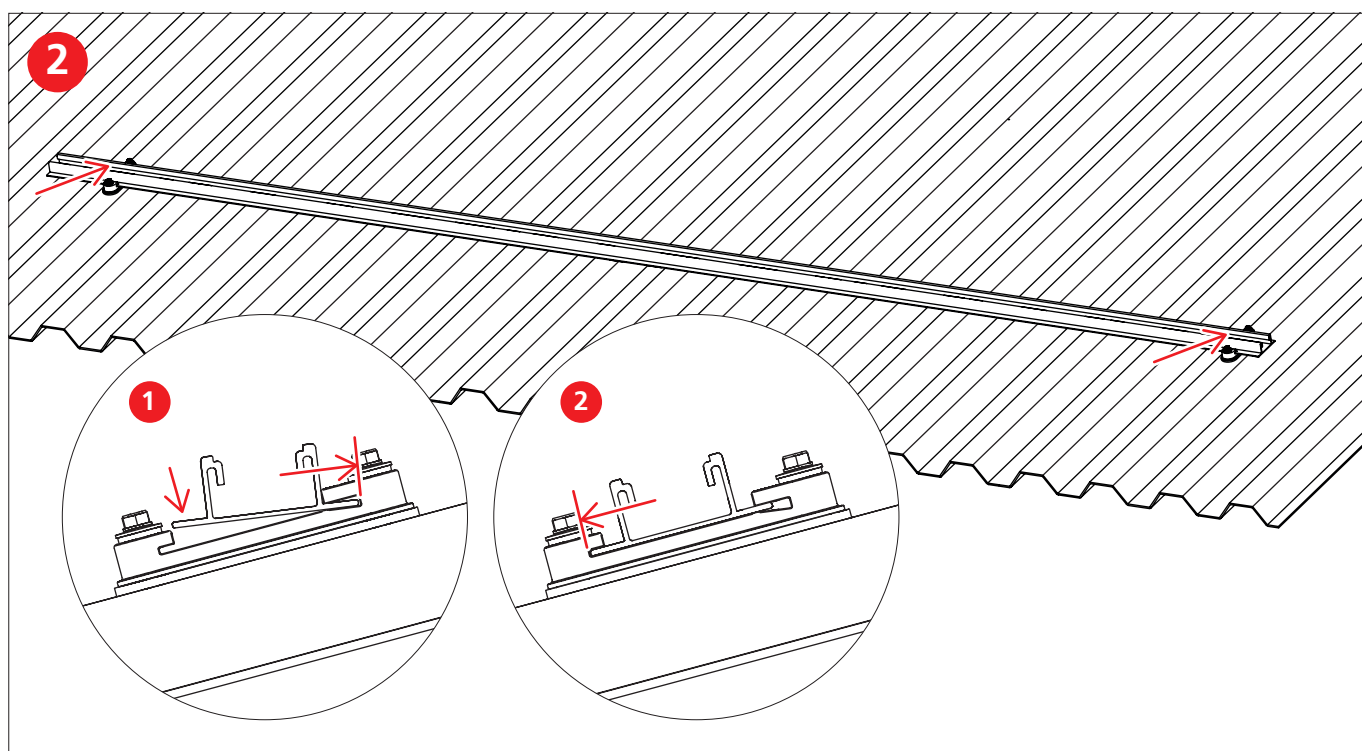
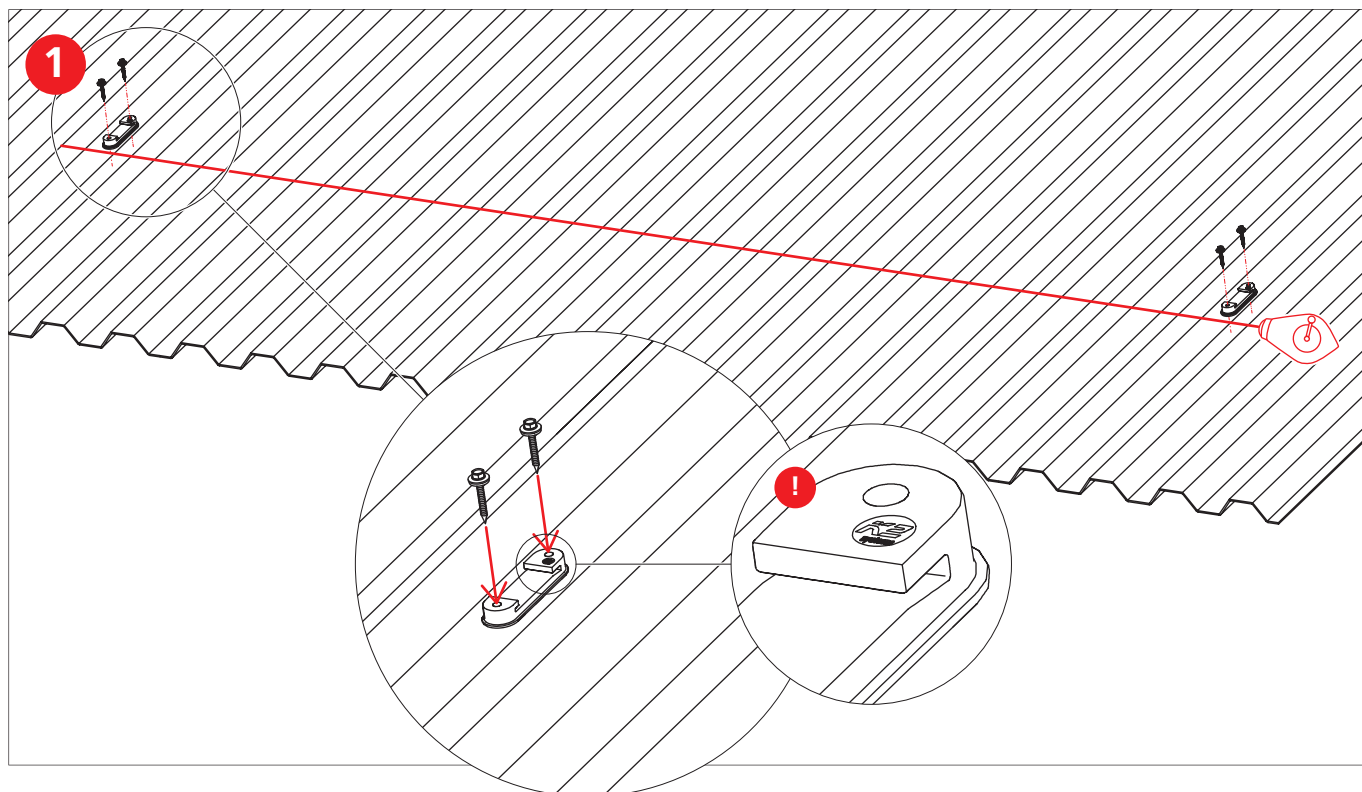

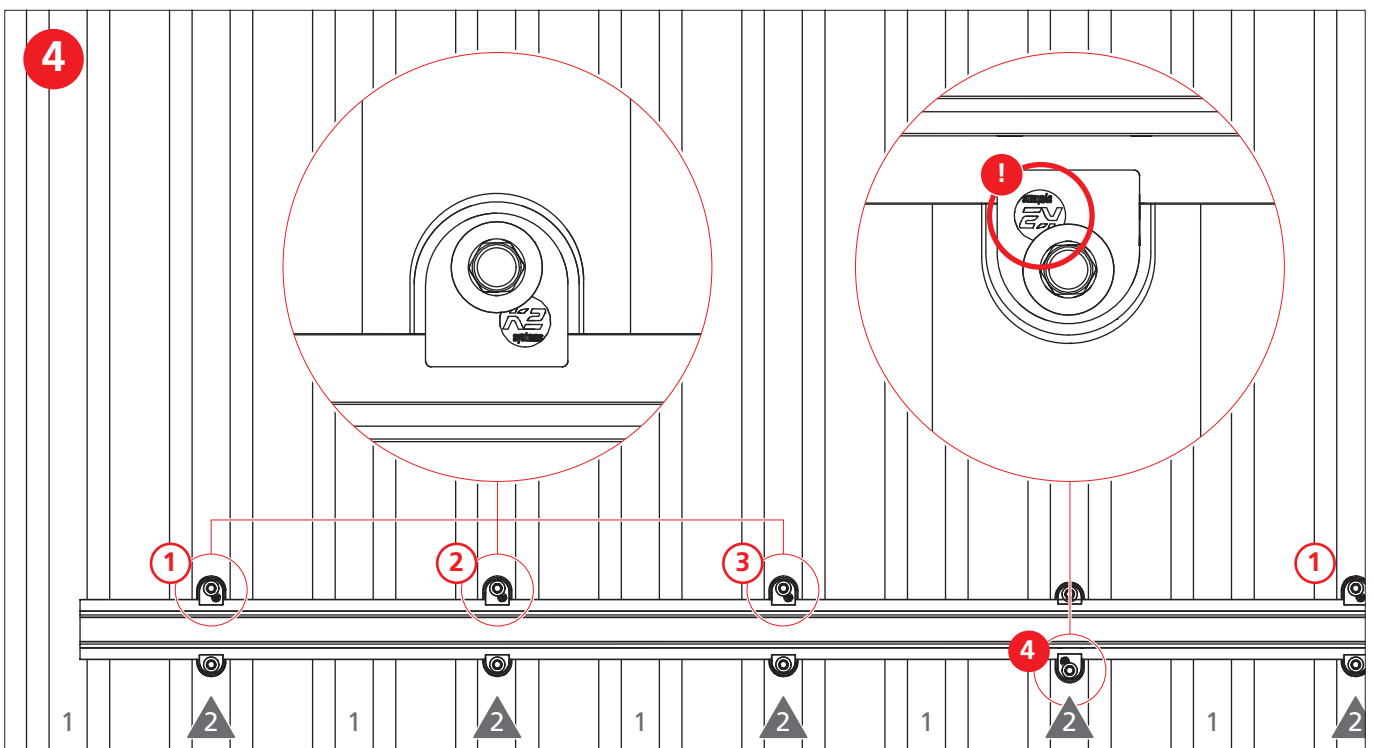
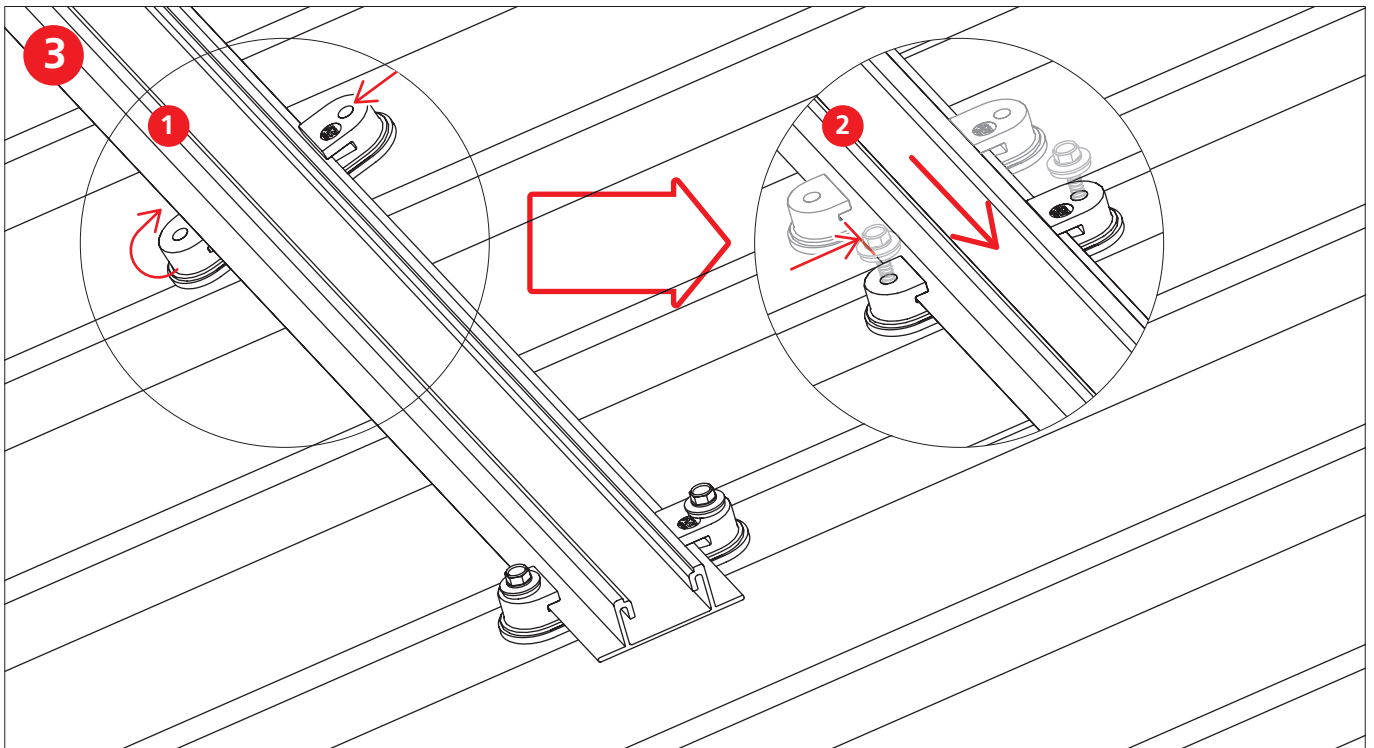

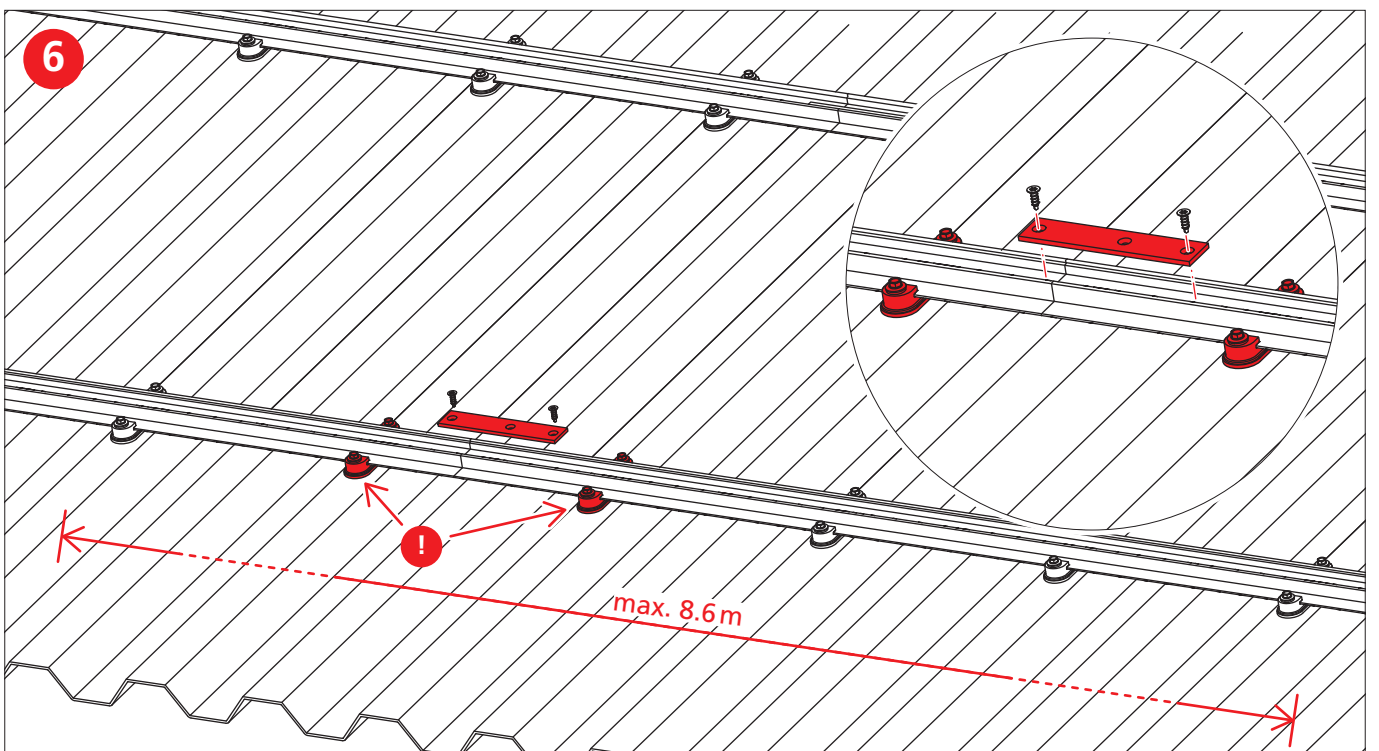
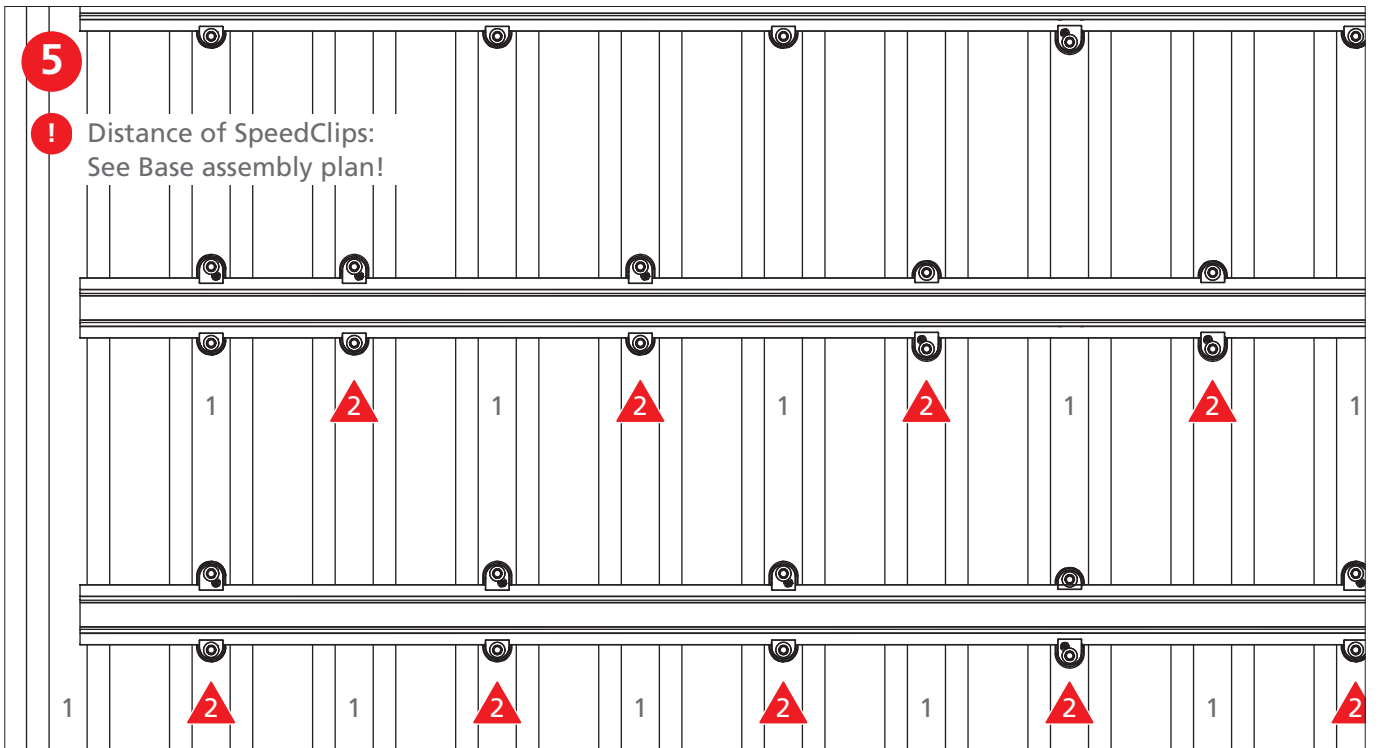

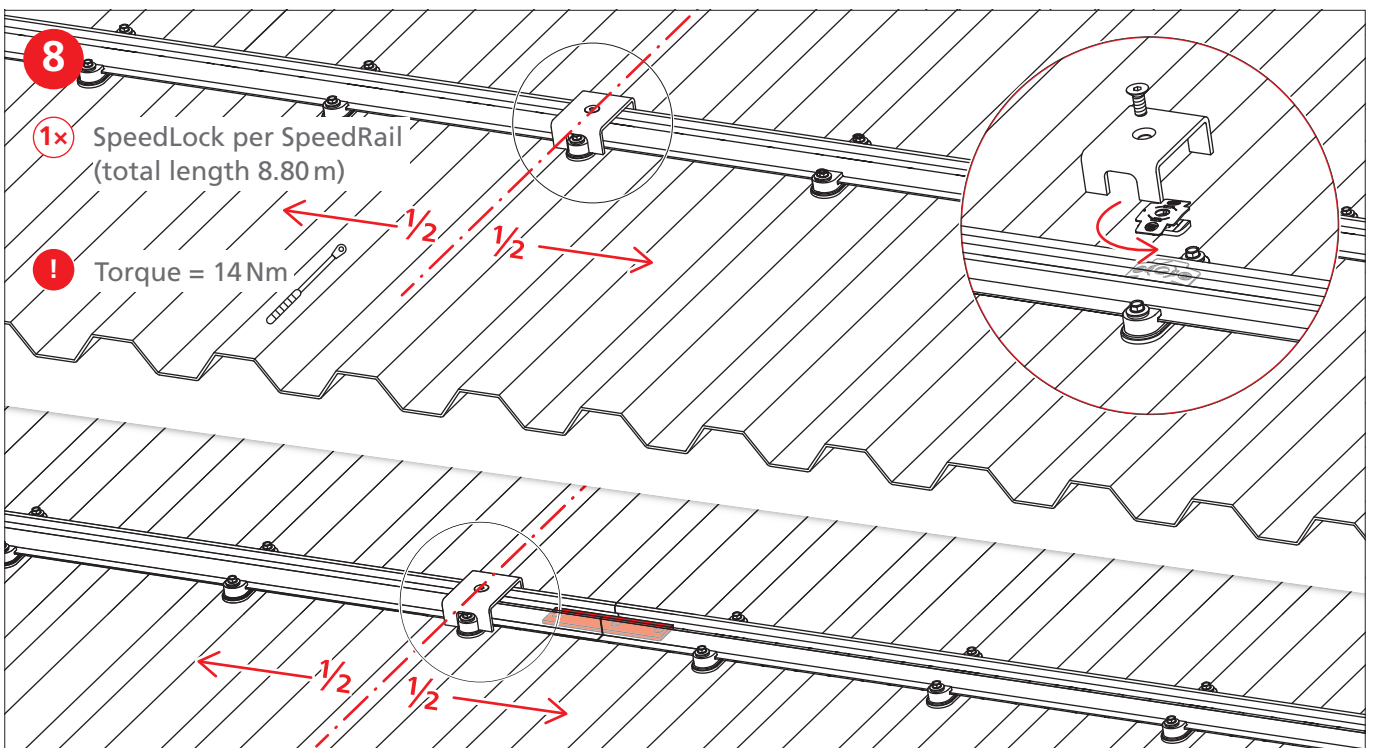
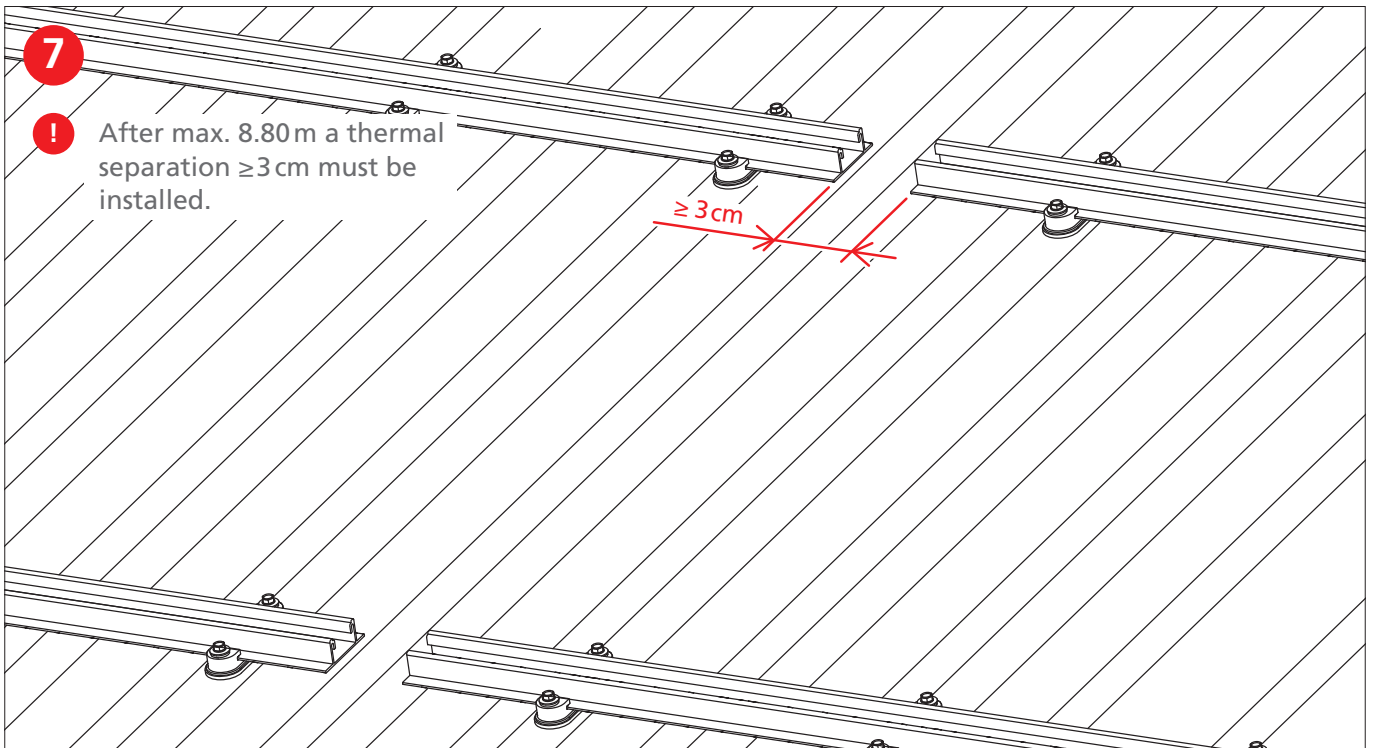

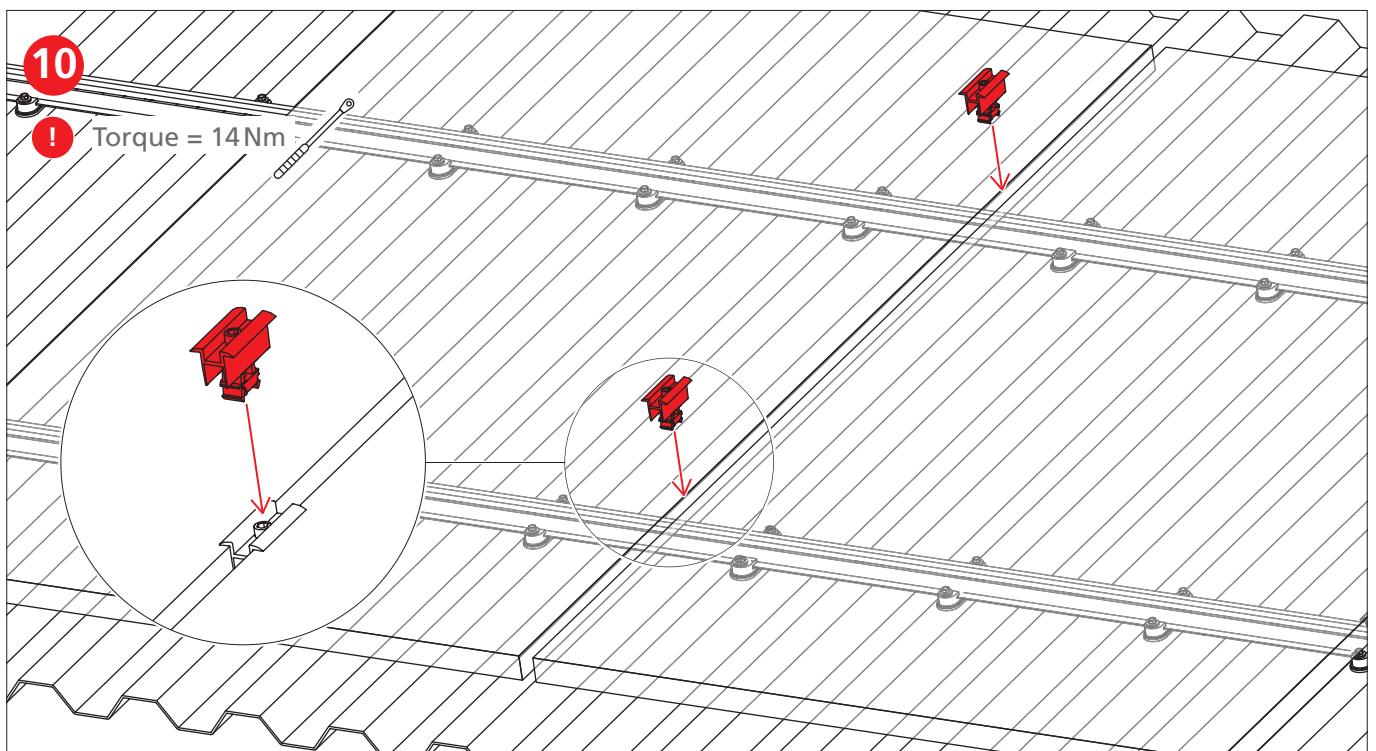
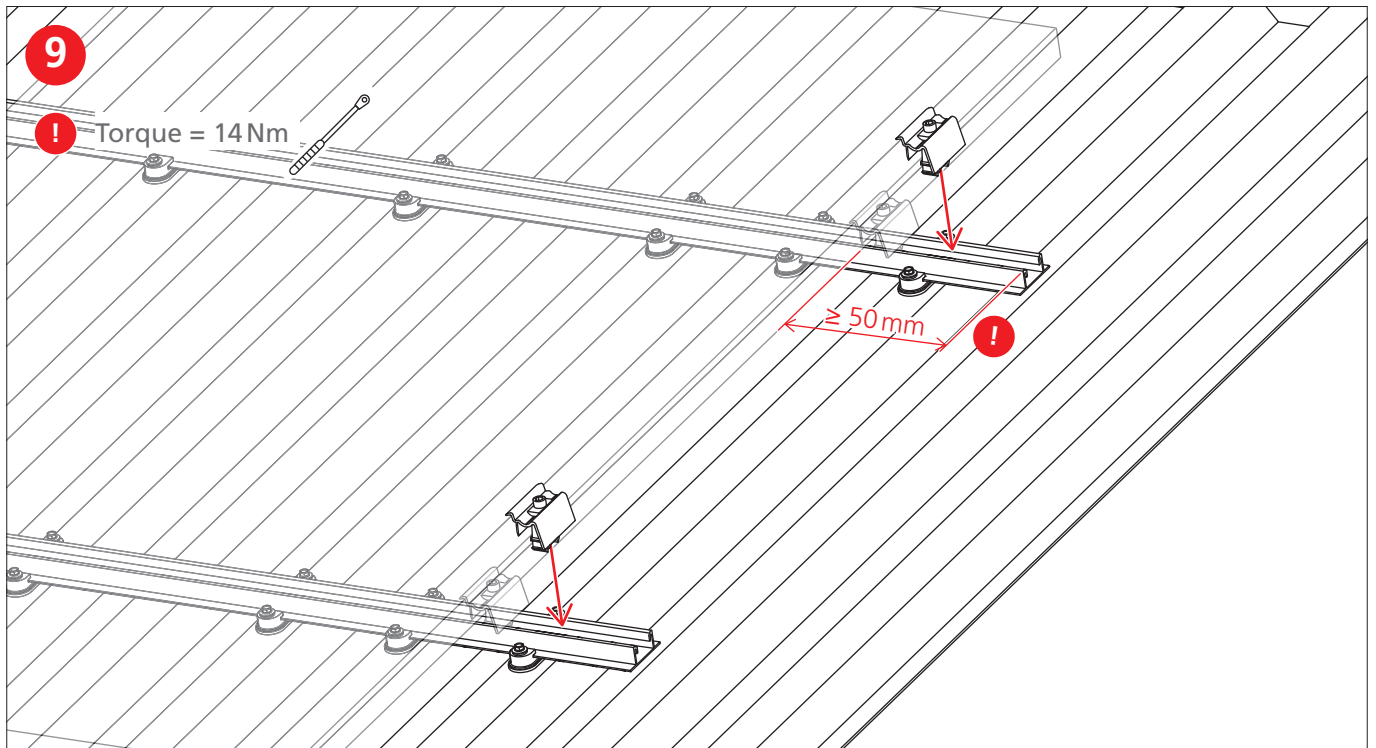

# Alternative system assemblies

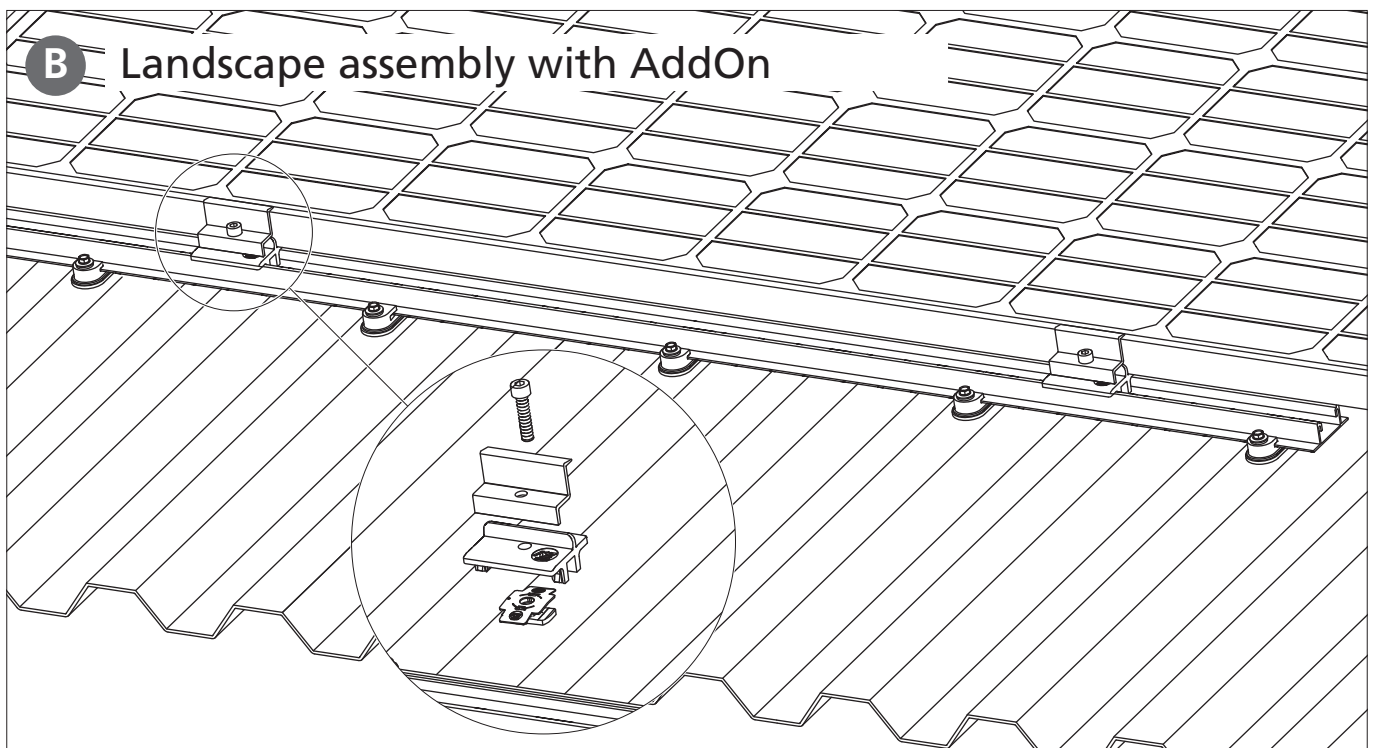
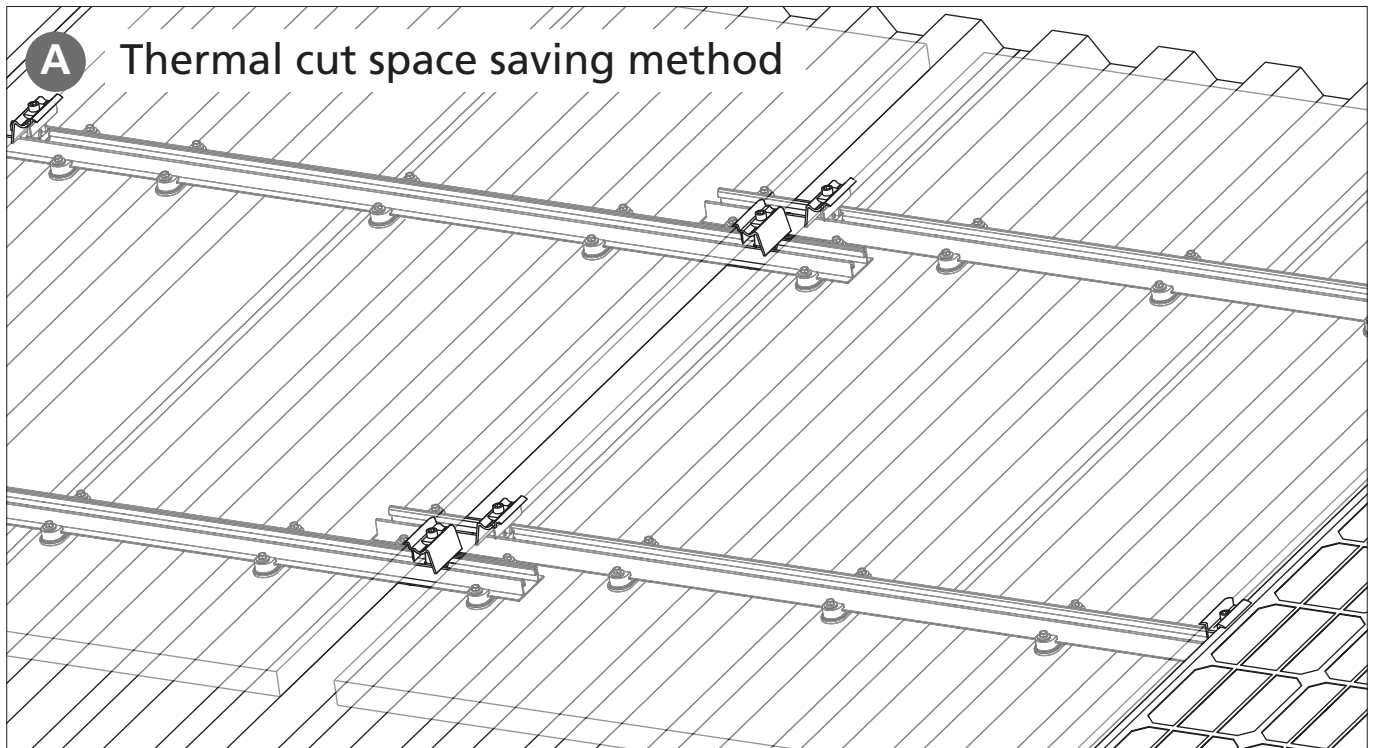



# Landscape assembly with two layers of rails

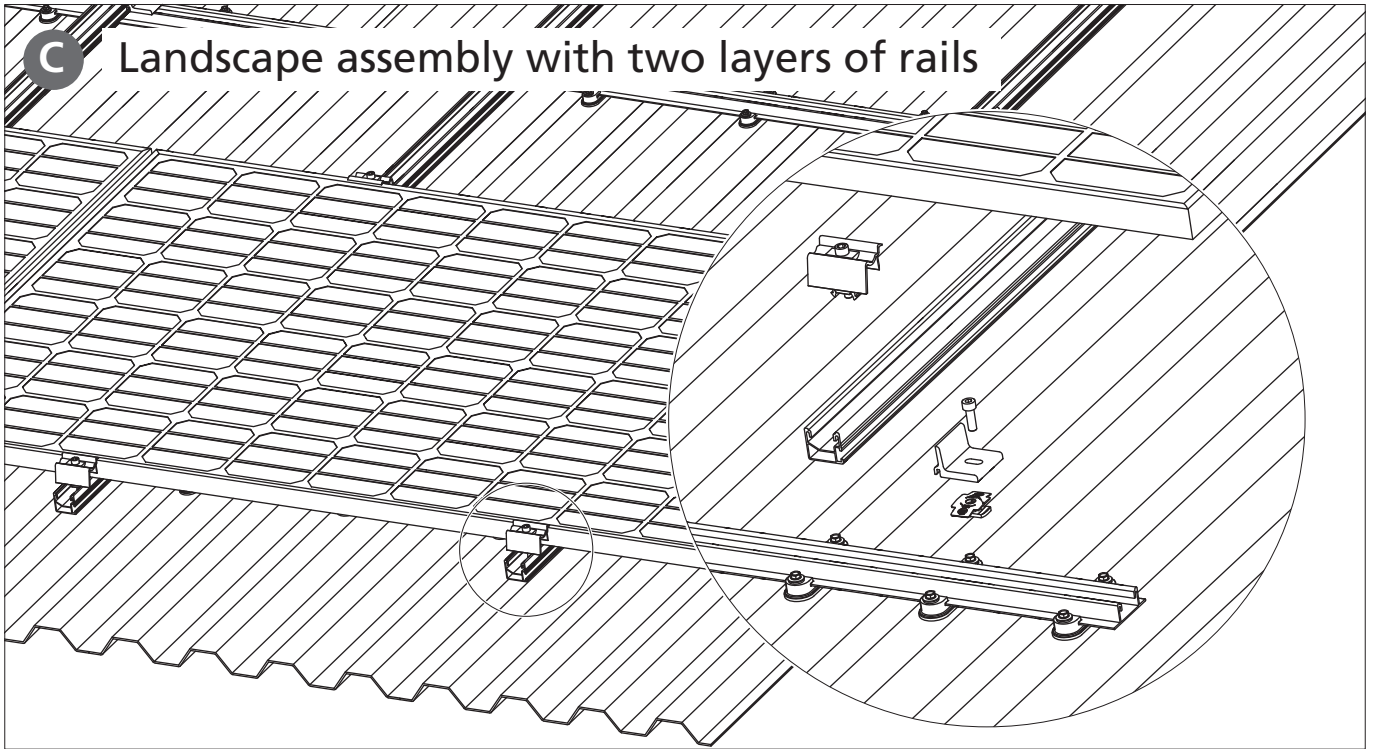



# Notes





## Thank you for choosing a K2 mounting system.

Mounting systems from K2 Systems are quick and easy to install. We hope these instructions have helped. Please contact us with any questions or suggestions for improvement. Our contact data:

- ▶ [www.k2-systems.com/en/contact](http://www.k2-systems.com/en/contact)
- ▶ **Service Hotline: +49 (0)7159 42059-0**

German law shall apply excluding the UN Convention on CISG. Place of venue is Stuttgart.

Our General Terms of Business apply. Please refer: [www.k2-systems.com](http://www.k2-systems.com)

**K2 Systems GmbH**  
Industriestraße 18  
71272 Renningen  
Germany  
+49 (0) 7159 - 42059 - 0  
[info@k2-systems.com](mailto:info@k2-systems.com)  
[www.k2-systems.com](http://www.k2-systems.com)