

Sigen Energy Gateway Home Series

User Manual

Version: 03

Release date: 2025-04-22



Copyright Notice

Copyright© 2025 Sigenergy Technology Co., Ltd. All Rights Reserved.

Description in this document may contain predictive statements regarding financial and operating results, product portfolio, new technology, configurations and features of product. Several factors could cause difference between actual results and those expressed or implied in the predictive statements. Therefore, description in this document is provided for reference purpose only and constitutes neither an offer nor an acceptance. Sigenergy Technology Co., Ltd. may change the information at any time without notice.

 **SIGENERGY** and other Sigenergy trademarks are owned by Sigenergy Technology Co., Ltd.

All trademarks and registered trademarks in this document belong to their owners.



Website



LinkedIn



YouTube

www.sigenergy.com

Contents

Revision History	5
Overview	6
Chapter 1 Safety Precautions.....	7
Chapter 2 Product Introduction.....	9
2.1 Product Features	9
2.2 Product Appearance	10
2.2.1 Sigen Gateway HomeMax SP.....	10
2.2.2 Sigen Gateway Home SP	13
2.2.3 Sigen Gateway Home SP 12K.....	15
2.2.4 Sigen Gateway SP AU.....	17
2.2.5 Sigen Gateway HomeMax SP LA.....	20
2.2.6 Sigen Gateway HomeMax TP.....	23
2.2.7 Sigen Gateway Home TP	26
2.2.8 Sigen Gateway (TP AU, HomeMax TP CN).....	28
2.2.9 Sigen Gateway Home TP (30K, 30K CN).....	31
2.2.10 Sigen Gateway HomePro TP	33
2.2.11 Sigen Gateway HomePro TP-L.....	36
2.3 Label Description.....	39
2.4 Supported Power Supply Methods for the Power Grid.....	40
2.5 Introduction to system wiring	41
Chapter 3 Site Selection Requirements	50
Chapter 4 Equipment Installation and Wiring	53
Chapter 5 mySigen App Query	54
Chapter 6 System Maintenance	55
6.1 Power Off.....	55
6.1.1 Sigen Gateway HomeMax SP.....	56
6.1.2 Sigen Gateway Home SP	57
6.1.3 Sigen Gateway Home SP 12K.....	58
6.1.4 Sigen Gateway SP AU.....	59
6.1.5 Sigen Gateway HomeMax SP LA.....	60

6.1.6 Sigen Gateway HomeMax TP.....	61
6.1.7 Sigen Gateway Home TP.....	62
6.1.8 Sigen Gateway (TP AU, HomeMax TP CN).....	63
6.1.9 Sigen Gateway Home TP (30K, 30K CN).....	64
6.1.10 Sigen Gateway HomePro TP.....	65
6.1.11 Sigen Gateway HomePro TP-L.....	66
6.2 Routine Maintenance.....	67
6.3 Troubleshooting.....	69
6.4 Operations on Bypass Switch.....	70
6.4.1 Bypass switch closing procedure.....	70
6.4.2 Bypass switch opening procedure.....	71
6.5 Emergency Treatment.....	72
Chapter 7 Appendix	73
7.1 Technical Parameter	73

Revision History

Version	Date	Description
03	2025.04.22	Added 2.2.10 Sigen Gateway HomePro TP Added 2.2.11 Sigen Gateway HomePro TP-L Updated Chapter 3 Site Selection Requirements Updated Chapter 6 System Maintenance
02	2024.12.24	Added 2.2.5 Sigen Gateway SP AU Added 2.2.9 Sigen Gateway (TP AU, HomeMax TP CN) Added 2.2.10 Sigen Gateway Home TP (30K, 30K CN) Updated 2.3 Label Description Added 2.4 Supported Power Supply Methods for the Power Grid Updated 2.5 Introduction to system wiring Updated Chapter 6 System Maintenance
01	2024.08.23	First official release.

Overview

Introduction



The focus of this document is to provide an overview of the Sigen Gateway Home Series, including product description, networking, system operation, maintenance, etc.

Readers

This document is suitable for product users and professionals.

Sign Definition

The following signs may be used in the document to indicate security precautions or key information. Before installation, operation, and maintenance of the equipment, familiarize yourself with signs and their definitions.

Signs	Definition
 Danger	Danger. Failure to comply will result in death or serious personal injury.
 Warning	Warning. Failure to comply will result in serious personal injury or property damage.
 Caution	Caution. Failure to comply will result in property damage.
Tips	Important or key information, and supplementary operation tips.

Chapter 1 Safety Precautions

Basic Information

Before installation, operation, and maintenance of the equipment, familiarize yourself with this document.

The "Danger ", "Warning", "Caution" items described in this manual are only supplementary to all precautions.

The Company shall not be liable for equipment damage or property loss caused by the following reasons:

- Failure to obtain approval from the national, regional power authority.
- The installation environment does not meet international, national, or regional standards.
- Failure to observe local laws, regulations and norms when operating and maintaining equipment.
- The installation area does not meet the requirements of the equipment.
- Failure to follow the instructions and precautions in this document.
- Failure to follow the warning labels on equipment or tools.
- Negligent, improper operation or intentional damage.
- Damage caused by your or a third party's replacement of our equipment.
- The equipment is damaged by your or the third-party company to use the accessories supplied with the package and purchase and use the accessories of the same specifications for installation.
- Equipment damage caused by improper operations such as disassembling, replacing, or modifying the software code without authorization.
- Equipment damage caused by force majeure (such as war, earthquake, fire, storm, lightning, flood, debris flow, etc.).
- Damage caused by the failure of the natural environment or external power parameters to meet the standard requirements of the equipment during actual operation (for example, the actual operating temperature of

the equipment is too high or too low).

- The equipment was stolen.
- The equipment is damaged after the warranty period.

Safety Requirements

Danger

- Do not expose the device to high temperature or heat sources (such as sunlight, fire, or heaters) around the equipment for a long time.
- Do not clean or soak the equipment with water, alcohol, or oil to avoid power leakage.
- Do not knock or impact the equipment. In case of an accident, please stop using the equipment immediately and contact your installer or sales representative. The equipment shall be inspected and evaluated by professional personnel before continuing to use.

Caution

- Do not use the equipment with faults. If the equipment appears abnormal (for example, appearance distortion), contact your installer or sales representative. You are prohibited from disassembling it on their own.
- Carbon dioxide fire extinguishers and ABC dry powder fire extinguishers are recommended at home. It is prohibited to disassemble the equipment by yourself.

Do not use the equipment in the following situations:

- When connected to public infrastructure systems.
- When connected to emergency medical equipment.
- When connected to elevators and other control devices.
- Any other critical systems.

Chapter 2 Product Introduction

2.1 Product Features

Function

Gateway products can be used in household PV storage and pure storage applications for data collection and monitoring, off-grid backup power switching, Generator control, and energy management, and more. The gateway products must be used in conjunction with our battery packs and inverters.

Model description

This document covers the following product models:

S/N	models
1	Sigen Gateway HomeMax SP
2	Sigen Gateway Home SP
3	Sigen Gateway Home SP 12K
4	Sigen Gateway SP AU
5	Sigen Gateway HomeMax SP LA
6	Sigen Gateway HomeMax TP
7	Sigen Gateway Home TP
8	Sigen Gateway TP AU
9	Sigen Gateway HomeMax TP CN
10	Sigen Gateway Home TP 30K
11	Sigen Gateway Home TP 30K CN
12	Sigen Gateway HomePro TP
13	Sigen Gateway HomePro TP-L

2.2 Product Appearance

2.2.1 Sigen Gateway HomeMax SP

Dimensions

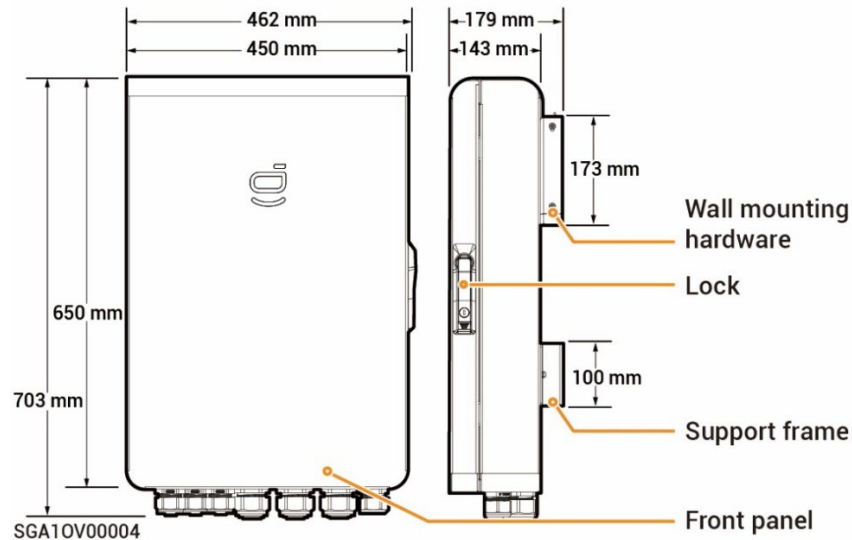

Bottom View

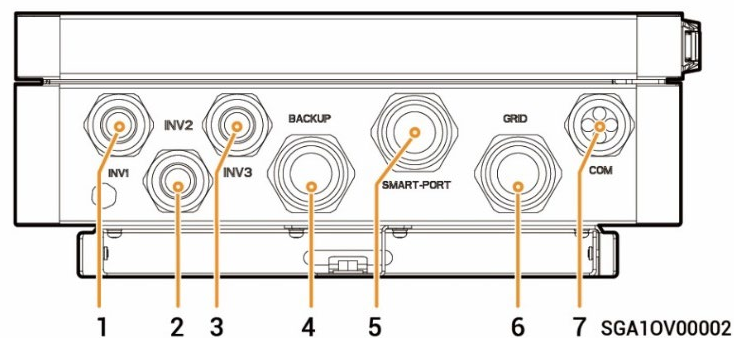

S/N	Marking	Description
1	INV1	Wire-in port of inverter 1
2	INV2	Wire-in port of inverter 2
3	INV3	Wire-in port of inverter 3
4	BACKUP	Wire-in port of backup household loads
5	SMART-PORT	Wire-in port for smart Loads/ Generator
6	GRID	Wire-in port of power grid
7	COM	Wire-in port of communication

Interior View

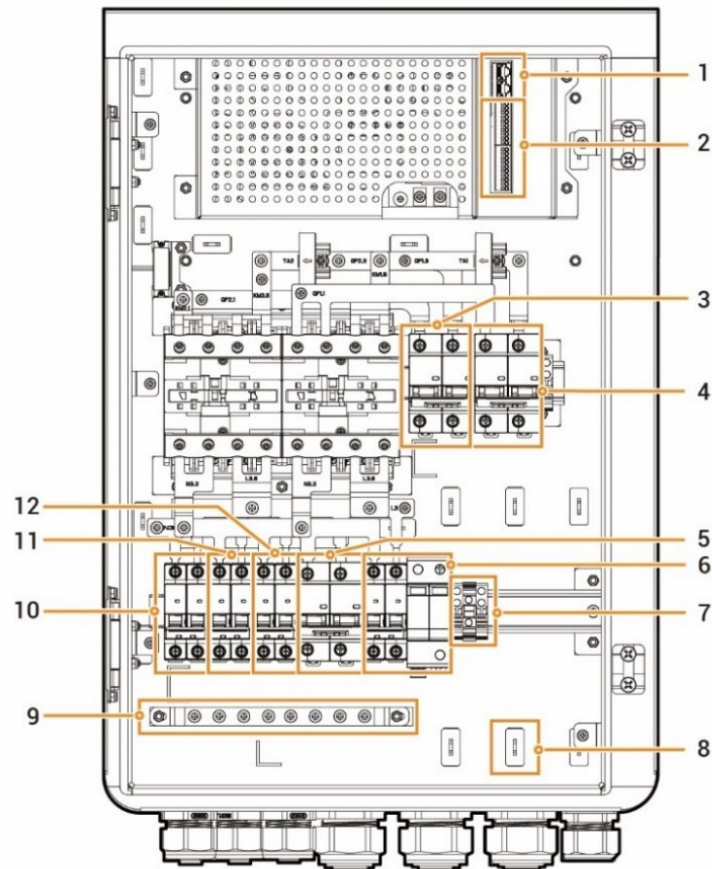

SGA10V00003

S/N	Label	Description
1	-	FE interfaces
2	-	DI, and DO interfaces
3	QF2	Miniature circuit breaker (connecting to Smart Loads ^[1] /Generator)
4	QF1	Miniature circuit breaker (connecting to Power grid)
5	QF6	Miniature circuit breaker (connecting to Backup Household loads)
6	QF8	Surge protective device switch
7	GND	GND
8	-	Cable clamp
9	-	Earthing bar

10	QF3	Miniature circuit breaker (connecting to Inverters 1)
11	QF4	Miniature circuit breaker (connecting to Inverters 2)
12	QF5	Miniature circuit breaker (connecting to Inverters 3)

Note [1]:

- All the power equipment in the owner's home can be connected as smart loads.
- To ensure that this product maximizes the benefits to users, it is recommended that the high-power equipment be connected as smart loads (Third-party inverter, heat pumps, pool heaters, clothes dryers, immersion heaters, etc.), which can be cut off when the energy storage system has low power. Other low-power equipment are connected as household loads (lights, routers, etc.)

2.2.2 Sigen Gateway Home SP

Dimensions

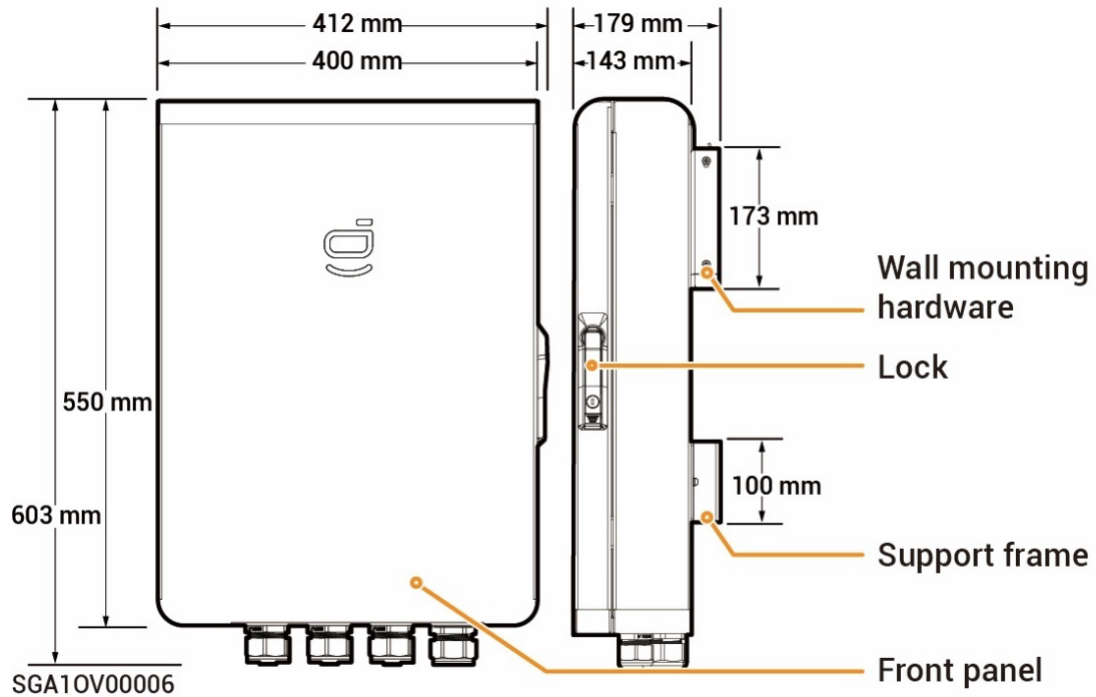

Bottom View

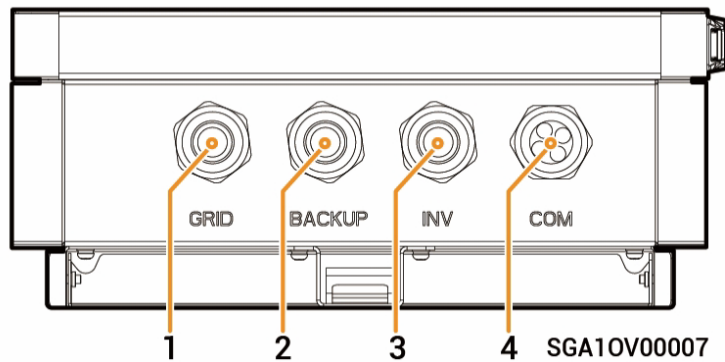

S/N	Marking	Description
1	GRID	Wire-in port of power grid
2	BACKUP	Wire-in port of backup Household loads
3	INV	Wire-in port of inverter
4	COM	Wire-in port of communication

Interior View

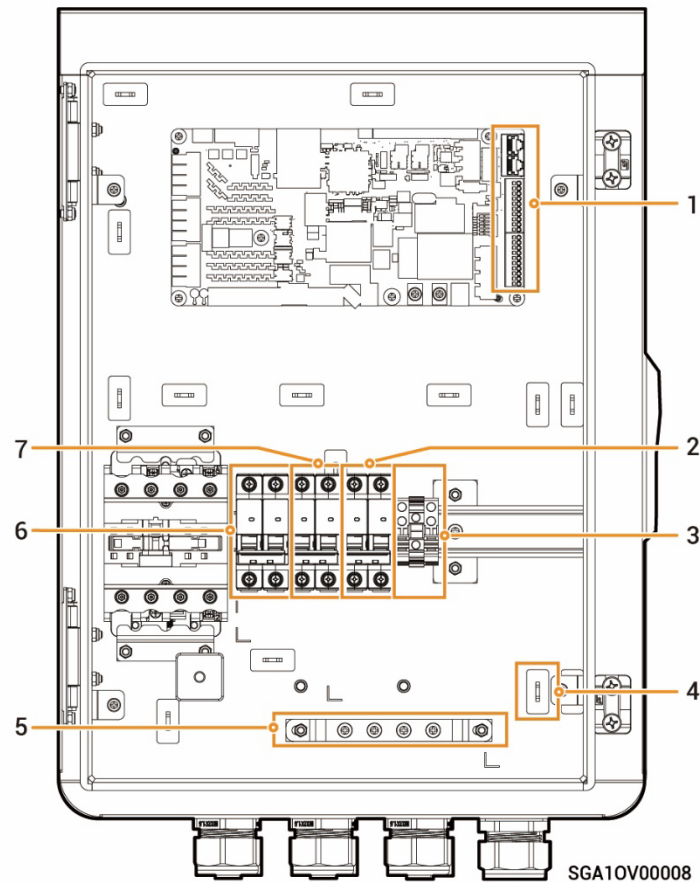

S/N	Label	Description
1	-	Communication terminal (connecting to FE or DI communication cable)
2	QF30	Miniature circuit breaker (connecting to Inverter)
3	GND	GND
4	-	Cable clamp
5	-	Grounding Bar
6	QF10	Miniature circuit breaker (connecting to Power grid)
7	QF50	Miniature circuit breaker (connecting to Backup Household loads)

2.2.3 Sigen Gateway Home SP 12K

Dimensions

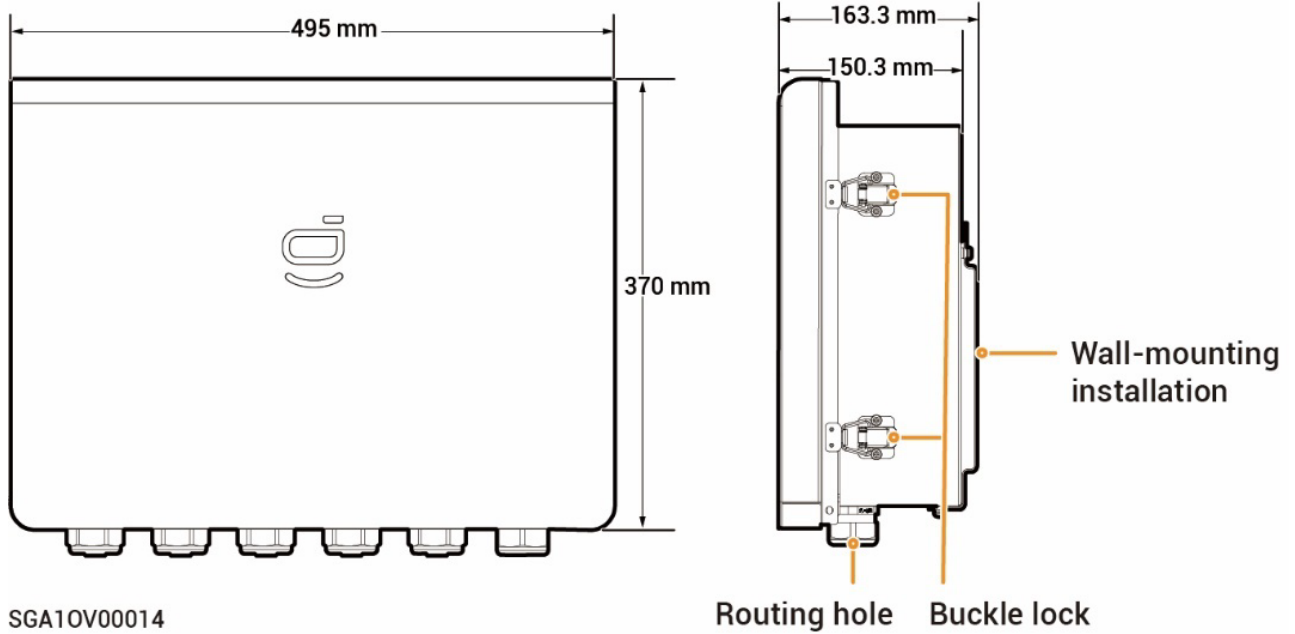

Interior View

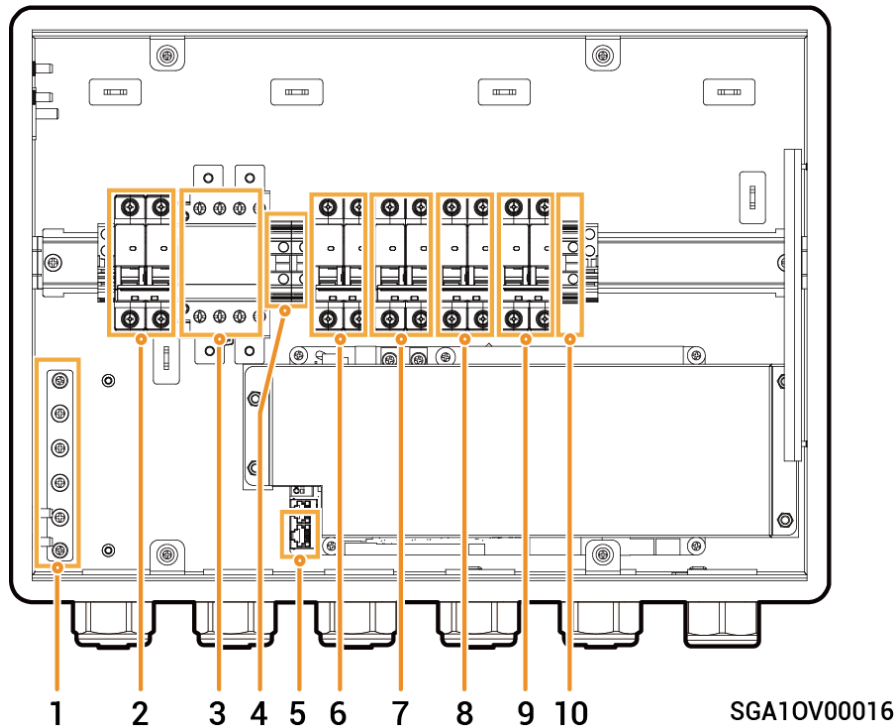

S/N	Label	Description
1	-	Grounding copper busbar
2	QS1	Bypass switch
3	KM1	Grid contactor
4	X1	Terminal (connecting to a non-backup load)
5	-	FE terminal
6	QF1	Miniature circuit breaker (connecting to the power grid)
7	QF2	Miniature circuit breaker (connecting to a single-phase inverter in a power range of 8.0 to 12.0 kW)
8	QF3	Miniature circuit breaker (connecting to a household load)
9	QF4	Miniature circuit breaker (connecting to a single-phase inverter in a power range of 3.0 to 6.0 kW)
10	-	Terminal (connecting to functional ground cable)

2.2.4 Sigen Gateway SP AU

Dimensions

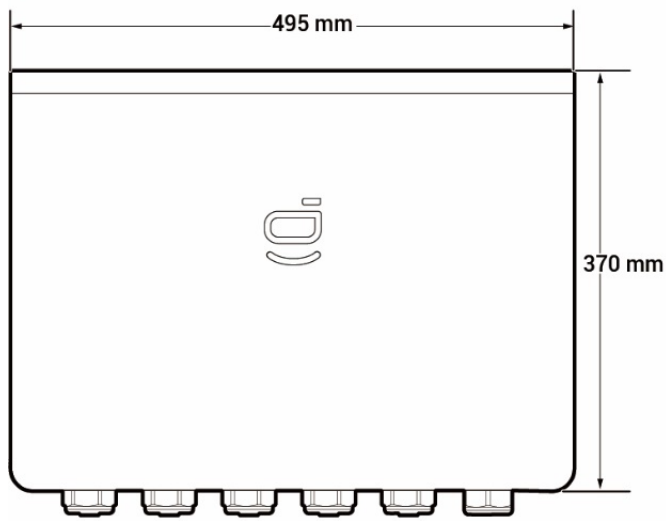

SGA10V00014

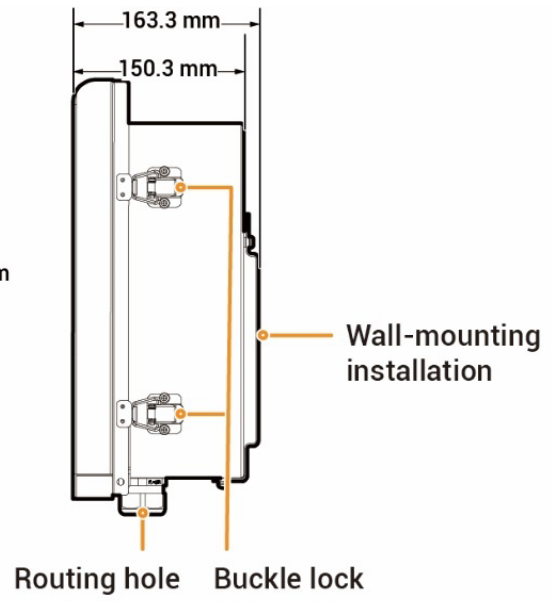

Interior View

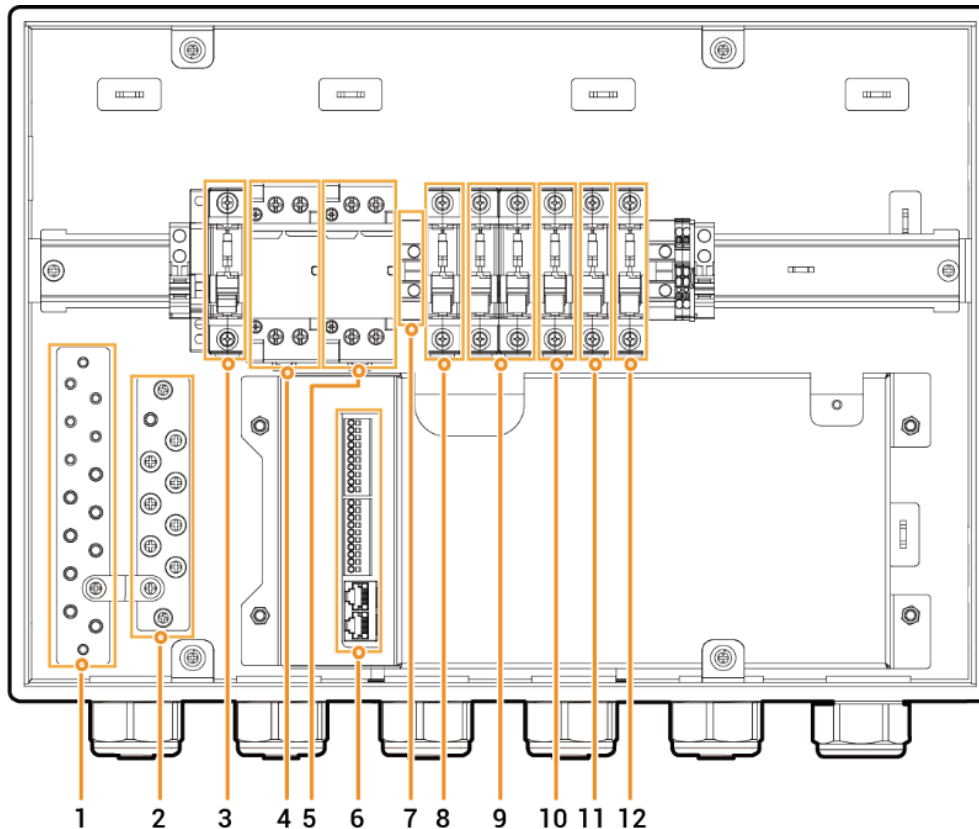

SGA10V00015

S/N	Label	Description
1	-	N-line copper busbar
2	-	Grounding copper busbar
3	QS1	Bypass switch
4	KM1	Grid contactor
5	KM2	Generator contactor
6	-	Communication terminal (connecting to FE or DI communication cable)
7	X1	Terminal (connecting to a non-backup load)
8	QF1	Miniature circuit breaker (connecting to the power grid)
9	QF2	Miniature circuit breaker (connecting to a Generator/smart load ^[1])

10	QF3	Miniature circuit breaker (connecting to a single-phase inverter in a power range of 8.0 to 10.0 kW)
11	QF4	Miniature circuit breaker (connecting to a single-phase inverter in a power range of 5.0 to 6.0 kW)
12	QF5	Miniature circuit breaker (connecting to a household load)

Note [1]:

- All the power equipment in the owner's home can be connected as smart loads.
- To ensure that this product maximizes the benefits to users, it is recommended that the high-power equipment be connected as smart loads (Third-party inverter, heat pumps, pool heaters, clothes dryers, immersion heaters, etc.), which can be cut off when the energy storage system has low power. Other low-power equipment are connected as household loads (lights, routers, etc.)

2.2.5 Sigen Gateway HomeMax SP LA

Dimensions

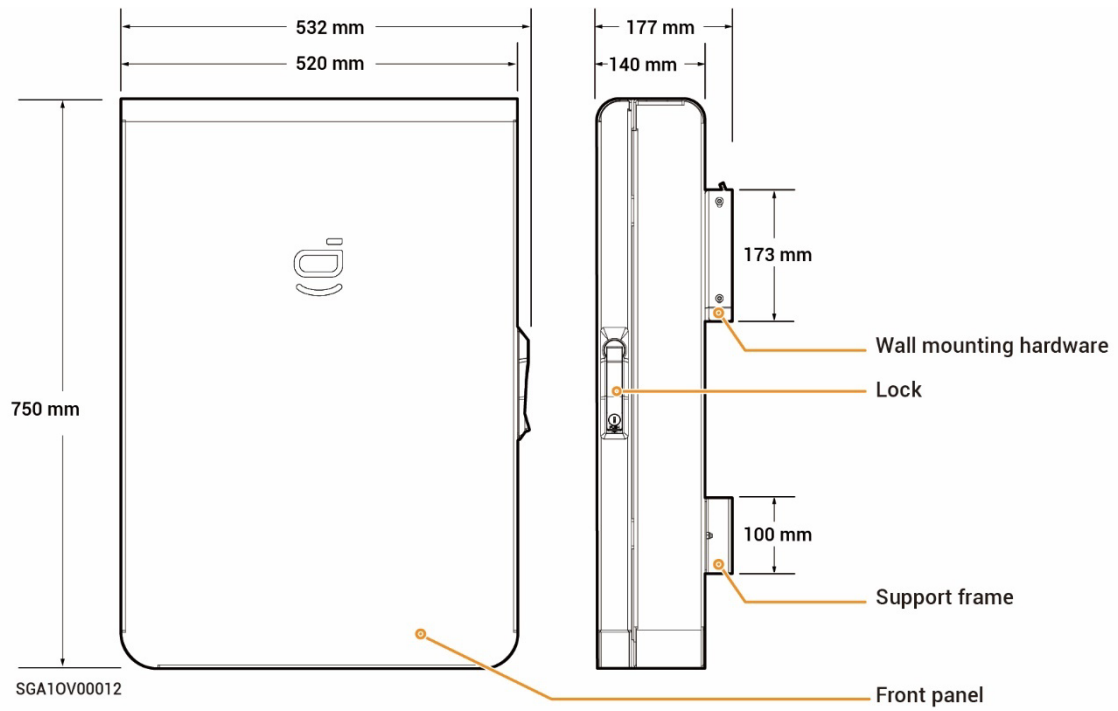

Interior View

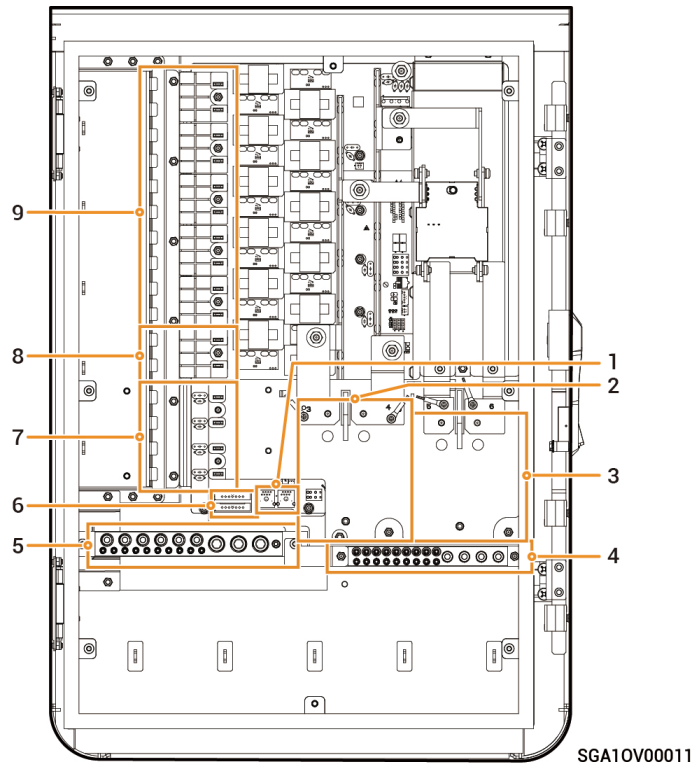

S/N	Description
1	FE interface
2	Mounting location of circuit breaker (connecting to Backup household loads)
3	Mounting location of circuit breaker (connecting to Power grid)
4	Grounding bar
5	N-bar
6	DI,DO interface
7	Mounting location of circuit breaker (connecting to Inverters 1, 2)
8	Mounting location of circuit breaker (connecting to Generator)
9	Mounting location of circuit breaker

	(connecting to Smart loads 1, 2, 3, 4, 5) ^[1]
--	--

Note [1]:

- All the power equipment in the owner's home can be connected as smart loads.
- To ensure that this product maximizes the benefits to users, it is recommended that the high-power equipment be connected as smart loads (Third-party inverter, heat pumps, pool heaters, clothes dryers, immersion heaters, etc.), which can be cut off when the energy storage system has low power. Other low-power equipment are connected as household loads (lights, routers, etc.)

2.2.6 Sigen Gateway HomeMax TP

Dimensions

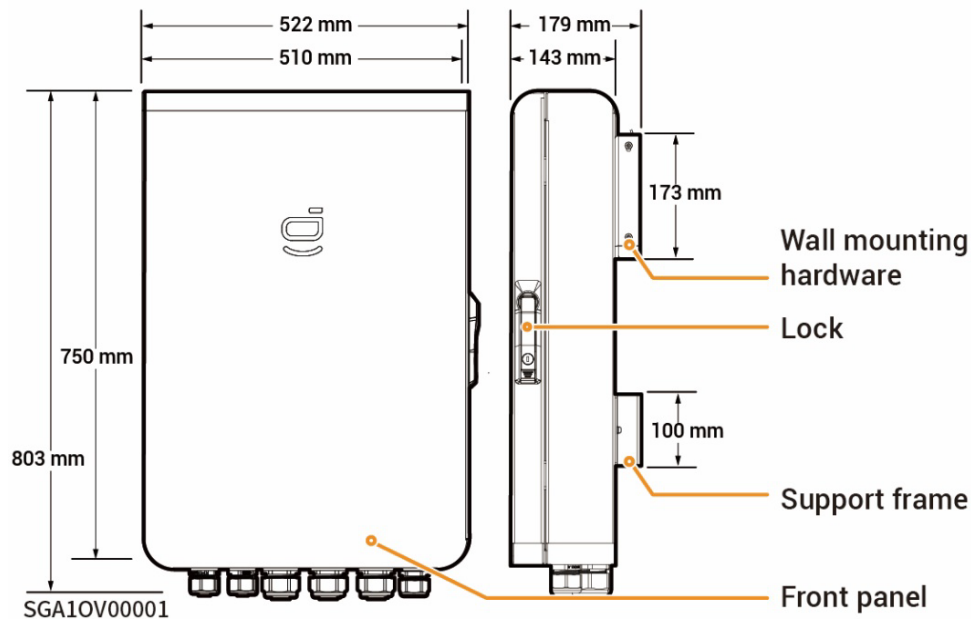

Bottom View

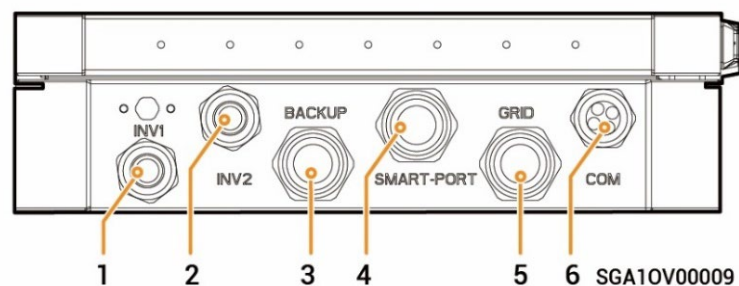

S/N	Marking	Description
1	INV1	Wire-in port of inverter 1
2	INV2	Wire-in port of inverter 2
3	BACKUP	Wire-in port of backup Household loads
4	SMART-PORT	Wire-in port for smart loads /Generator
5	GRID	Wire-in port of power grid
6	COM	Wire-in port of communication

Interior View

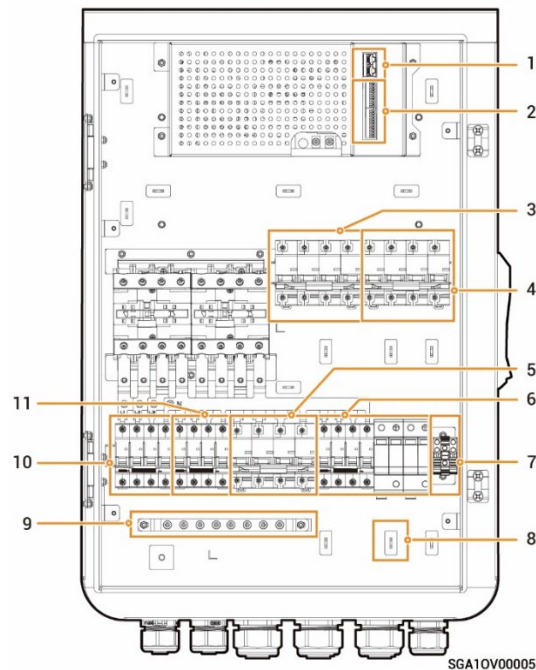

S/N	Label	Description
1	-	FE interfaces
2	-	DI, and DO interfaces
3	QF2	Miniature circuit breaker (connecting to Smart Loads ^[1] /Generator)
4	QF1	Miniature circuit breaker (connecting to Power grid)
5	QF5	Miniature circuit breaker (connecting to Backup Household loads)
6	QF6	Surge protective device switch
7	GND	GND
8	-	Cable clamp
9	-	Earthing bar
10	QF3	Miniature circuit breaker (connecting to Inverters 1)

11	QF4	Miniature circuit breaker (connecting to Inverters 2)
-----------	-----	--

Note [1]:

- All the power equipment in the owner's home can be connected as smart loads.
- To ensure that this product maximizes the benefits to users, it is recommended that the high-power equipment be connected as smart loads (Third-party inverter, heat pumps, pool heaters, clothes dryers, immersion heaters, etc.), which can be cut off when the energy storage system has low power. Other low-power equipment are connected as household loads (lights, routers, etc.)

2.2.7 Sigen Gateway Home TP

Dimensions

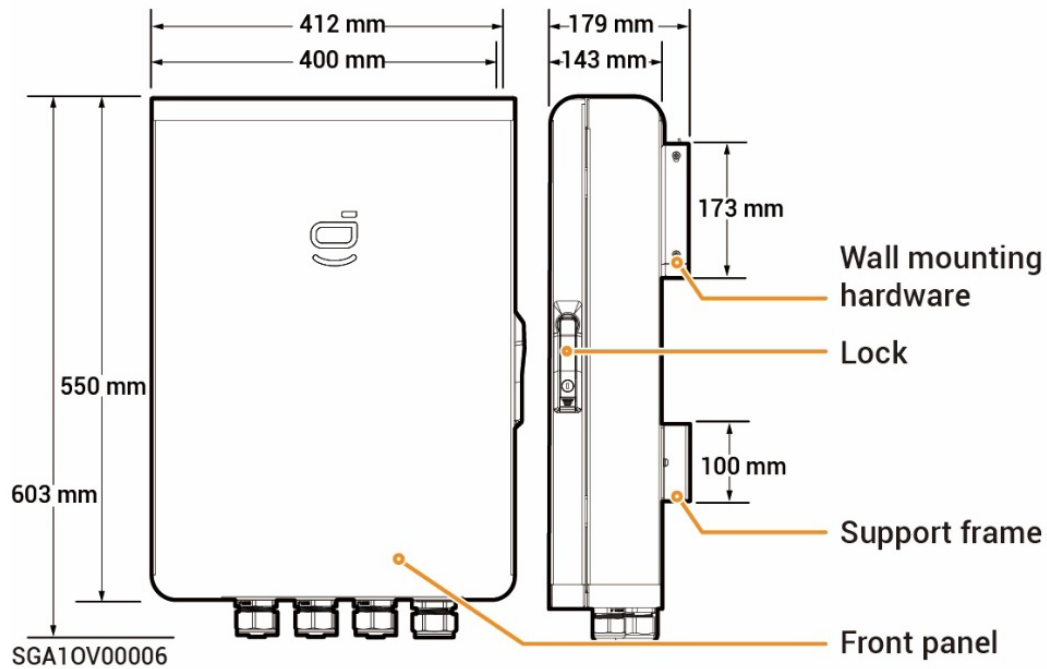

Bottom View

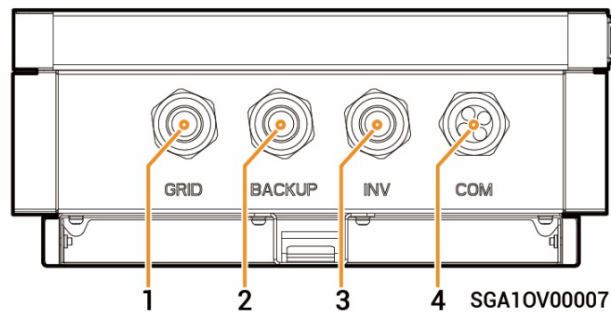

S/N	Marking	Description
1	GRID	Wire-in port of power grid
2	BACKUP	Wire-in port of Backup Household loads
3	INV	Wire-in port of inverter
4	COM	Wire-in port of communication

Interior View

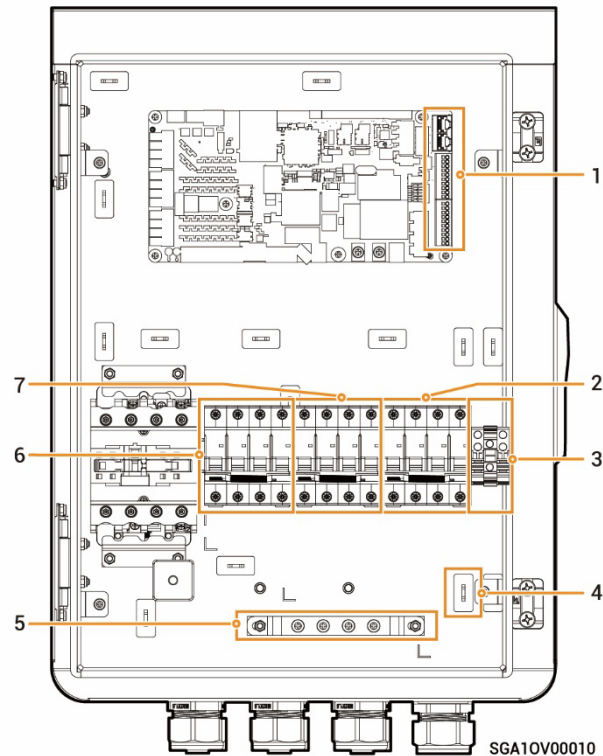

S/N	Label	Description
1	-	Communication terminal (connecting to FE or DI communication cable)
2	QF30	Miniature circuit breaker (connecting to Inverter)
3	GND	GND
4	-	Cable clamp
5	-	Grounding bar
6	QF10	Miniature circuit breaker (connecting to Power grid)
7	QF50	Miniature circuit breaker (connecting to Backup Household loads)

2.2.8 Sigen Gateway (TP AU, HomeMax TP CN)

Dimensions

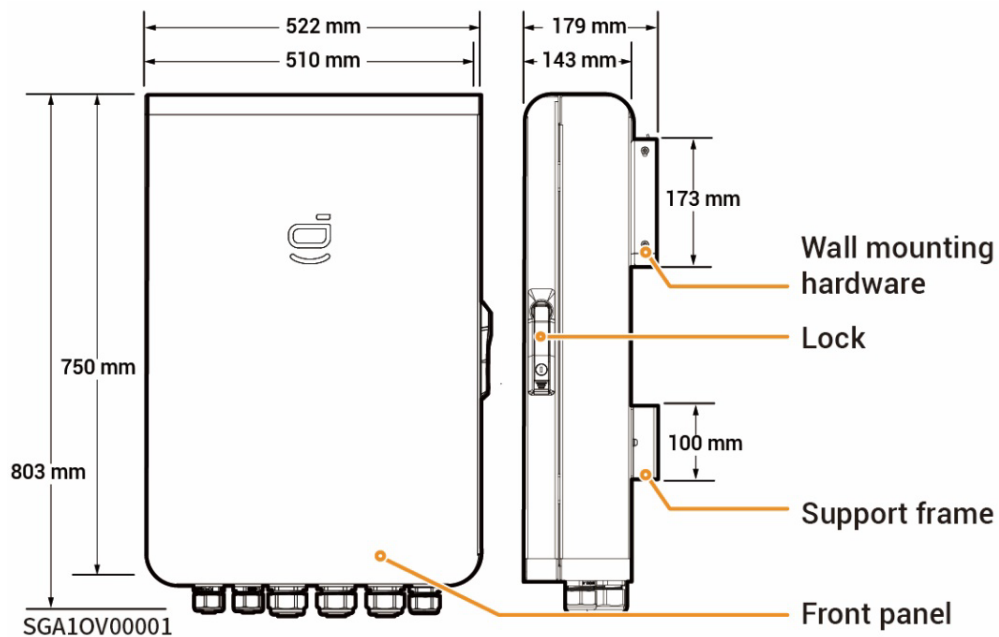

Bottom View

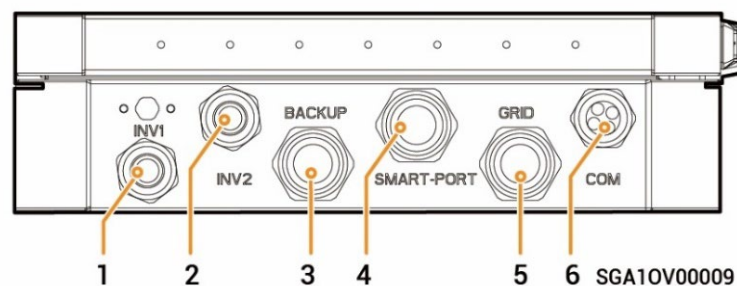

S/N	Marking	Description
1	INV1	Wire-in port of inverter 1
2	INV2	Wire-in port of inverter 2
3	BACKUP	Wire-in port of backup Household loads
4	SMART-PORT	Wire-in port for smart loads /Generator
5	GRID	Wire-in port of power grid
6	COM	Wire-in port of communication

Interior View

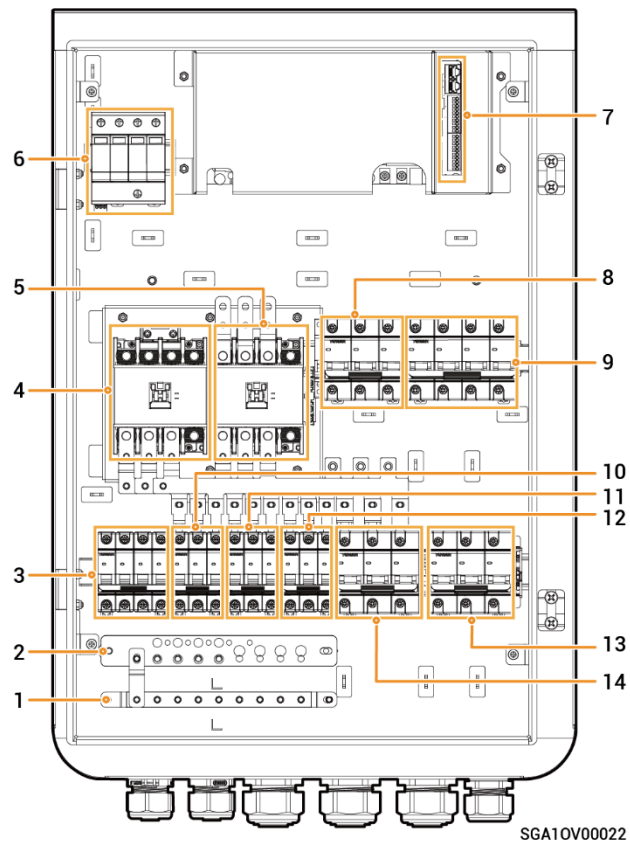

SGA10V00022

S/N	Label	Description
1	-	Grounding copper busbar
2	-	N-line copper busbar
3	QF7	Surge protective device switch
4	KM2	Generator contactor
5	KM1	Grid contactor
6	SPD	Surge protective device
7	-	Communication terminal (connecting to FE or DI communication cable)
8	QS1	Bypass switch

9	QF2	Miniature circuit breaker (connecting to a smart load ^[1] /Generator)
10	QF3	Miniature circuit breaker (connecting to a three-phase inverter in a power range of 17.0 kW to 30.0 kW)
11	QF4	Miniature circuit breaker (connecting to a three-phase inverter in a power range of 17.0 kW to 30.0 kW)
12	QF5	Miniature circuit breaker (connecting to a three-phase inverter in a power range of 5.0 kW to 15.0 kW)
13	QF1	Miniature circuit breaker (connecting to the power grid)
14	QF6	Miniature circuit breaker (connecting to a household load)

Note [1]:

- All the power equipment in the owner's home can be connected as smart loads.
- To ensure that this product maximizes the benefits to users, it is recommended that the high-power equipment be connected as smart loads (Third-party inverter, heat pumps, pool heaters, clothes dryers, immersion heaters, etc.), which can be cut off when the energy storage system has low power. Other low-power equipment are connected as household loads (lights, routers, etc.)

2.2.9 Sigen Gateway Home TP (30K, 30K CN)

Dimensions

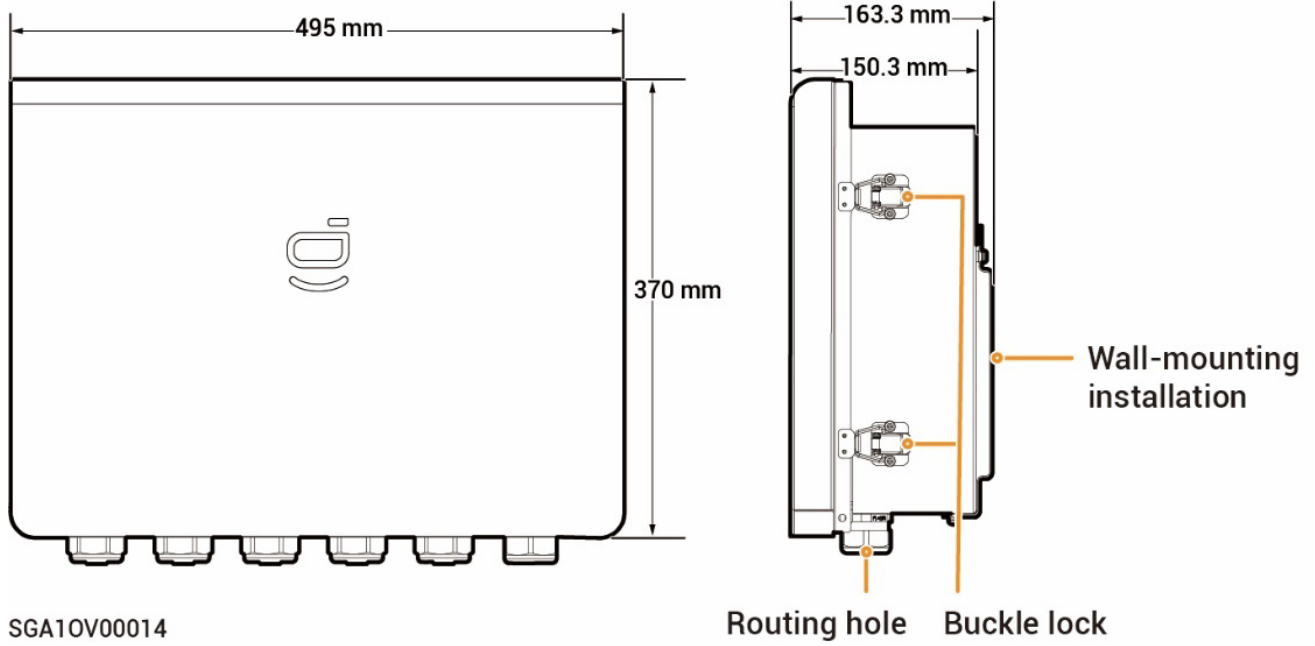

Interior View

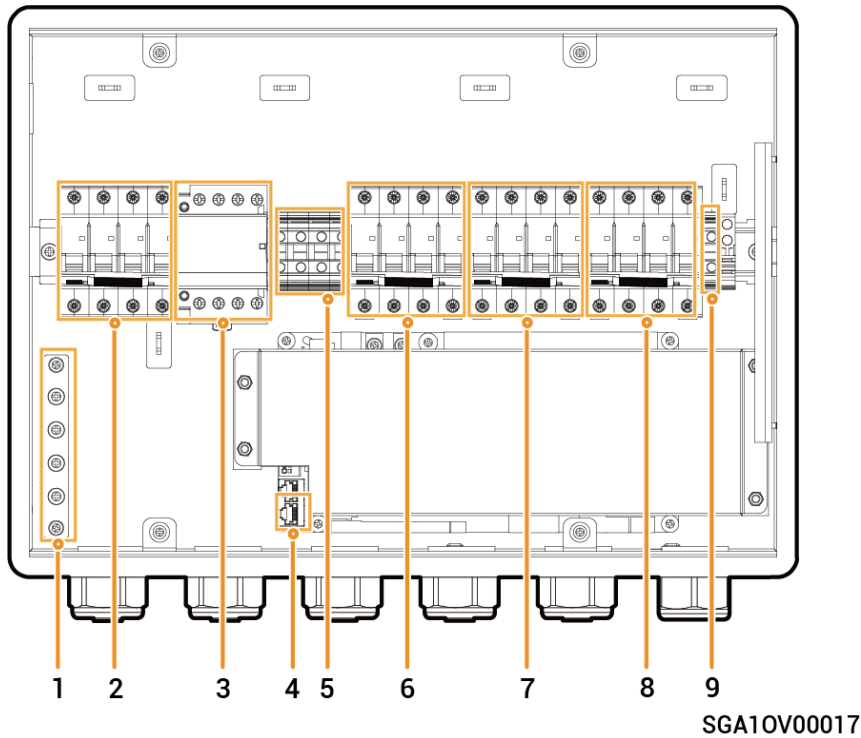

S/N	Label	Description
1	-	Grounding copper busbar
2	QS1	Bypass switch
3	KM1	Grid contactor
4	-	FE terminal
5	X1	Terminal (connecting to a non-backup load)
6	QF1	Miniature circuit breaker (connecting to the power grid)
7	QF2	Miniature circuit breaker (connecting to a three-phase inverter)
8	QF3	Miniature circuit breaker (connecting to a household load)
9	-	Terminal (connecting to functional ground cable)

2.2.10 Sigen Gateway HomePro TP

Dimensions

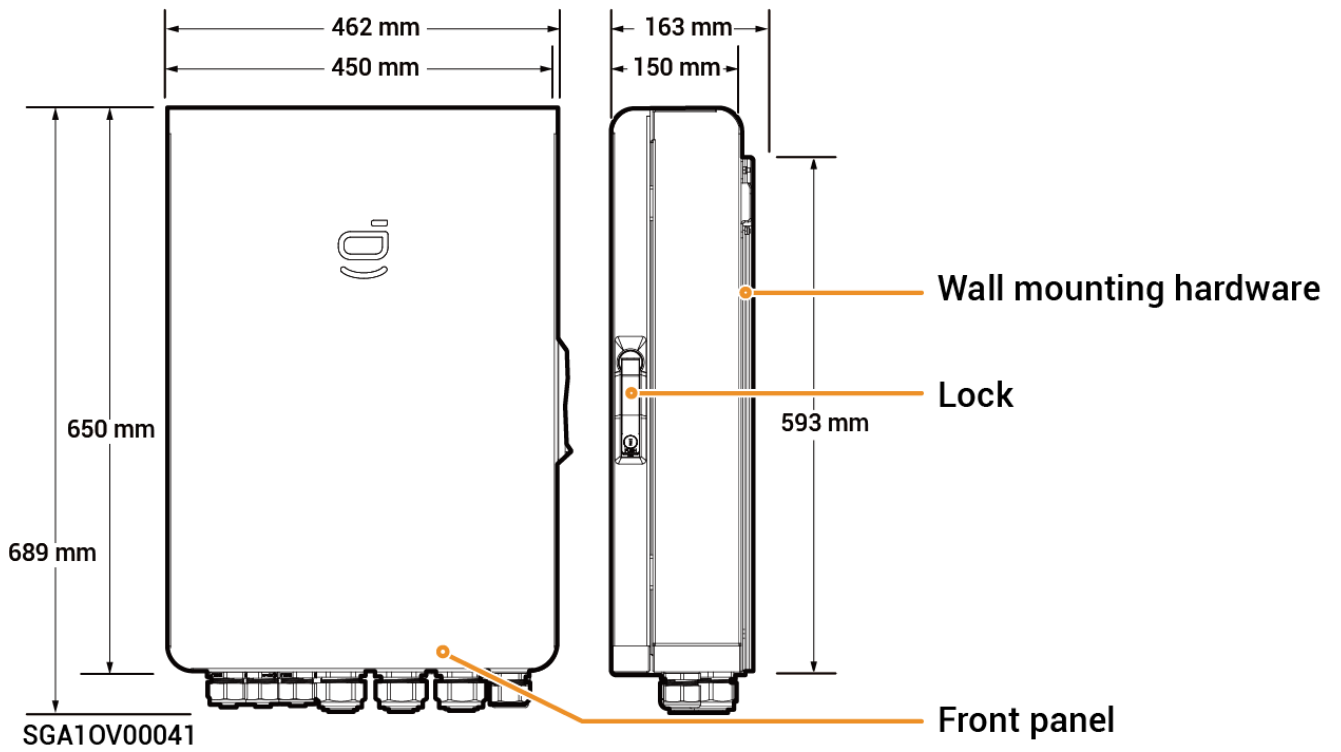

Interior View

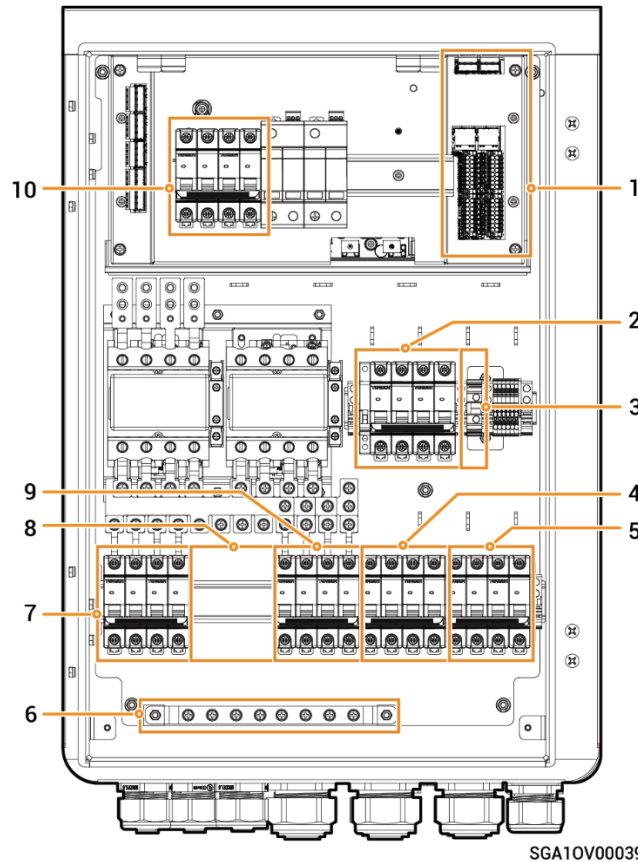

SGA10V00039

S/N	Label	Description
1	–	Communication terminal (connecting to FE or DI communication cable)
2	QS1	Bypass switch
3	GND	GND terminal
4	QF2	Miniature circuit breaker (connecting to Smart loads ^[1] /Generator)
5	QF1	Miniature circuit breaker (connecting to Power grid)
6	–	Grounding copper busbar
7	QF3	Miniature circuit breaker (connecting to Inverters 1)
8	–	(Optional) Mounting location of circuit breaker (connecting to Inverters 2) ^[2]
9	QF4	Miniature circuit breaker

		(connecting to Backup household loads)
10	QF5	Surge protection device

Note [1]:

- All the power equipment in the owner's home can be connected as smart loads.
- To ensure that this product maximizes the benefits to users, it is recommended that the high-power equipment be connected as smart loads (Third-party inverter, heat pumps, pool heaters, clothes dryers, immersion heaters, etc.), which can be cut off when the energy storage system has low power. Other low-power equipment are connected as household loads (lights, routers, etc.)

Note [2]:

The circuit breaker must be prepared by the owner. For specific specifications, please refer to the installation guide for the specific model.

2.2.11 Sigen Gateway HomePro TP-L

Dimensions

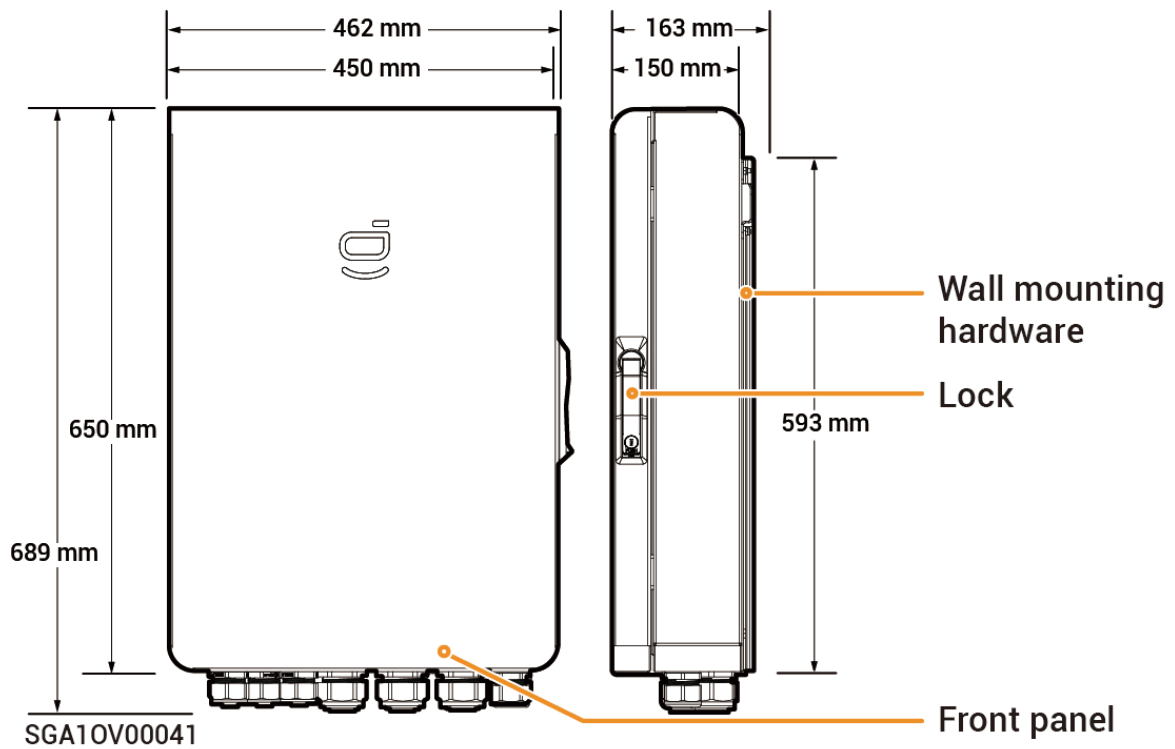

Interior View

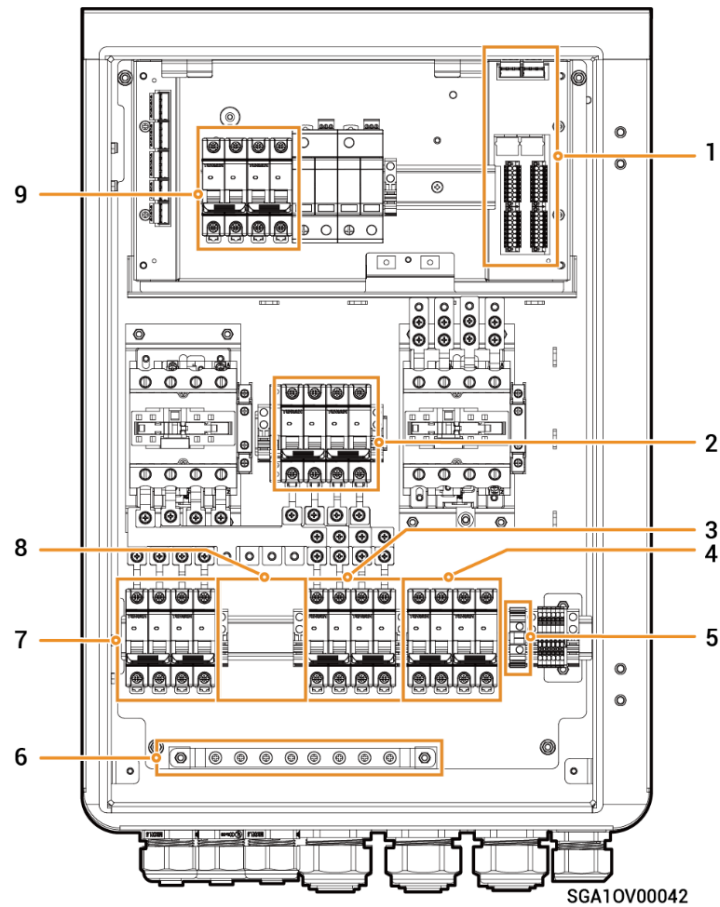





S/N	Label	Description
1	–	Communication terminal (connecting to FE or DI communication cable)
2	QS1	Bypass switch
3	QF3	Miniature circuit breaker (connecting to Backup household loads)
4	QF1	Miniature circuit breaker (connecting to the power grid)
5	GND	GND terminal
6	–	Grounding bar
7	QF2	Miniature circuit breaker (connecting to Inverter 1)
8		(Optional) Mounting location of circuit breaker (connecting to Inverters 2) ^[1]

9	QF4	Surge protective device switch
----------	-----	--------------------------------

Note [1]:

The circuit breaker must be prepared by the owner. For specific specifications, please refer to the installation guide for the specific model.

2.3 Label Description

Symbol	Definition
	Warning! Hazardous voltage. The equipment enclosure contains AC voltage. Please take protective measures before operating the equipment.
	After the equipment is powered off, internal components discharge in a delay time. Wait for the duration according to the delay time on the label until the equipment is fully discharged.
	Warning! Danger! Hot The surface of the equipment is hot when the equipment is operating. Do not touch it to avoid burns.
	Operate the equipment by referring to the User Manual.
	GND symbol

2.4 Supported Power Supply Methods for the Power Grid

- The grid supply methods supported include TN-S, TN-C-S, and TT.
- When TT is used as the power supply technique for the power grid, the voltage between N and PE is required to be $< 30\text{ V}$.

Gateway Single-phase Series Products:

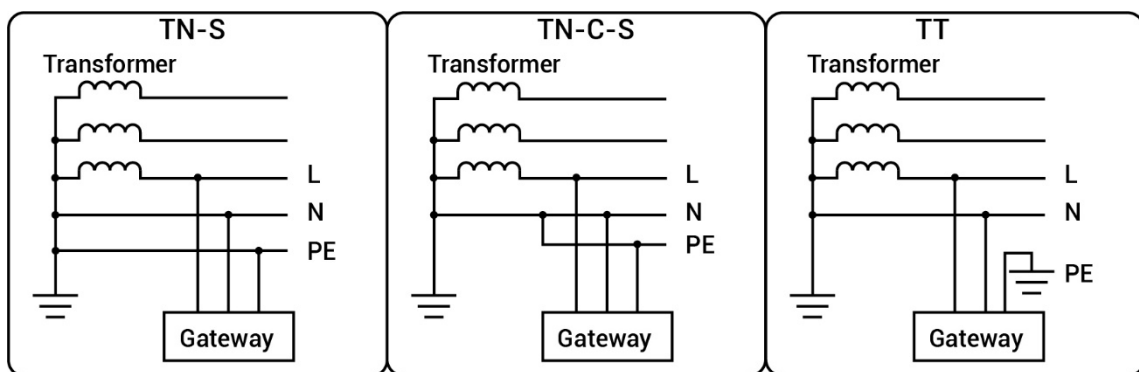

SVA10V00011

Gateway three-phase series products:

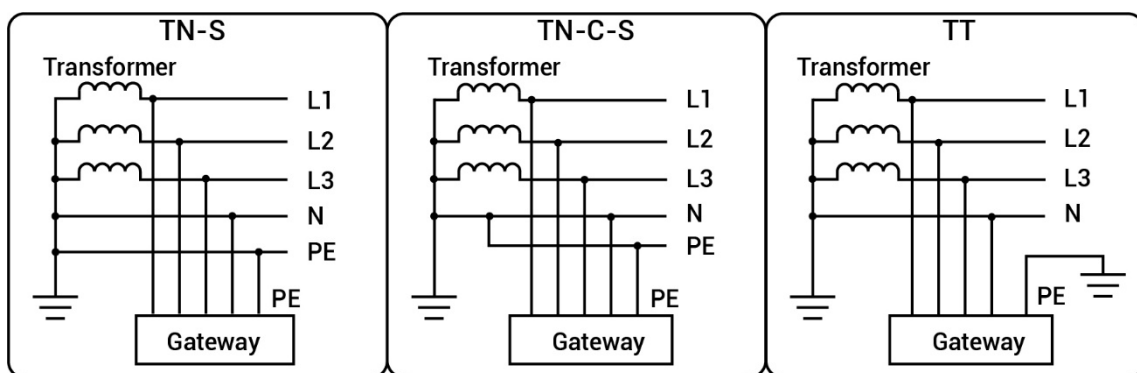

SVA10V00010

2.5 Introduction to system wiring

- This product is applicable to household backup power system networking scenarios. It must be used in conjunction with PV panels, inverters, battery packs, main control switches, loads, generators, and power grid.
- In the event of a power outage, the household energy storage system switches to off-grid operation mode. After the power grid resumes normal operation, the household energy storage system switches back to on-grid mode. This achieves a seamless switchover between PV storage and Generator.

Tips

- Under backup power networking, the duration of off-grid operation of the backup power load is related to the power supply capacity of the PV storage system. If there is an abnormality in the power supply of the PV storage system during off-grid operation (including but not limited to abnormal PV power generation, insufficient battery power, and abnormal power supplies to the Generator), the backup power load will still be unable to operate.
- The networking diagram takes two inverters as an example. The number of inverters that can be connected depends on the Gateway specification. For more information, see Table 2-1.

Table 2-1

S/N	Model	Number of Inverters that can be connected
1	Sigen Gateway HomeMax SP	3 units
2	Gateway Home SP	1 unit
3	Gateway Home SP 12K	2 units
4	Sigen Gateway SP AU	2 units
5	Sigen Gateway HomeMax SP LA	2 units

6	Sigen Gateway HomeMax TP	2 units
7	Sigen Gateway Home TP	1 unit
8	Sigen Gateway TP AU	2 units
9	Sigen Gateway HomeMax TP CN	2 units
10	Sigen Gateway Home TP 30K	1 unit
11	Sigen Gateway Home TP 30K CN	1 unit
12	Sigen Gateway HomePro TP	2 units
13	Sigen Gateway HomePro TP-L	2 unit

Whole home backup system wiring diagram

Single inverter (Gateway has the circuit breaker for connecting smart load/diesel generator)

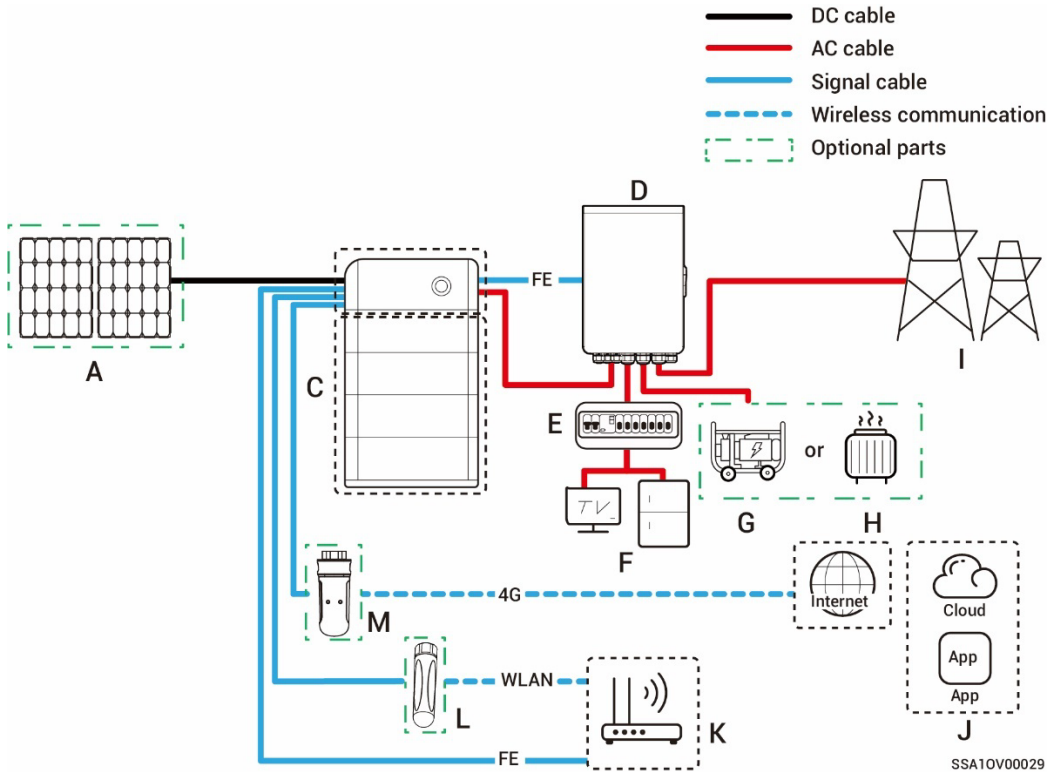

Single inverter (Gateway does not have the circuit breaker connected to the smart load/diesel generator)

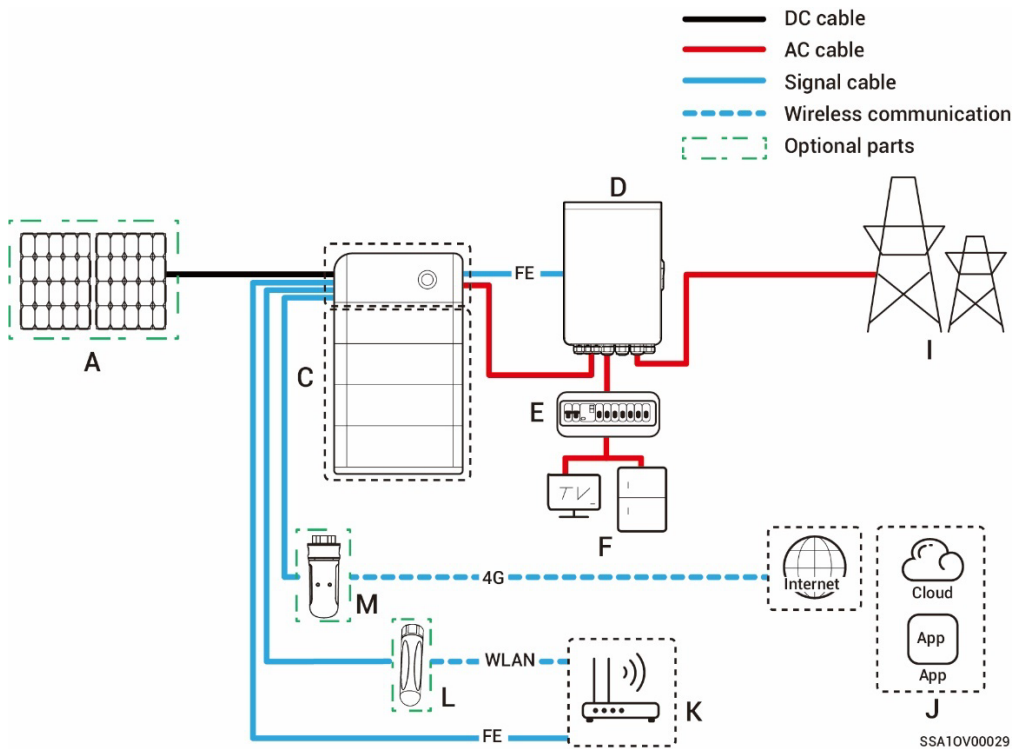

Multiple inverters (Gateway has the circuit breaker for connecting smart load/diesel generator)

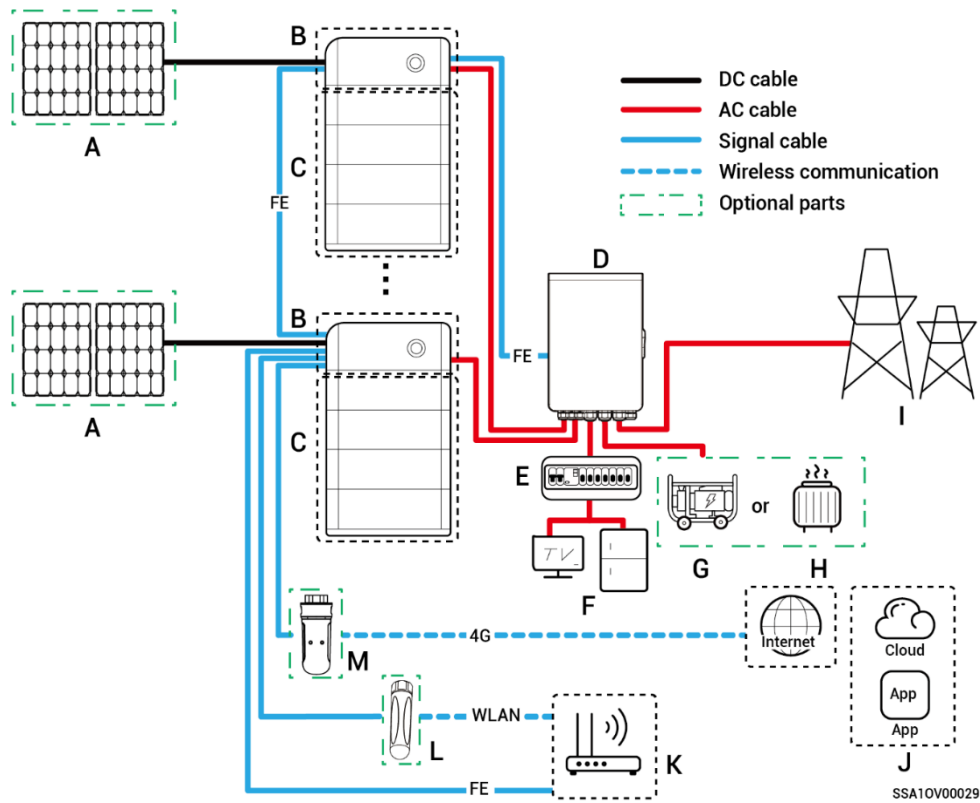

Multiple inverters (Gateway does not have the circuit breaker connected to the smart load/diesel generator)

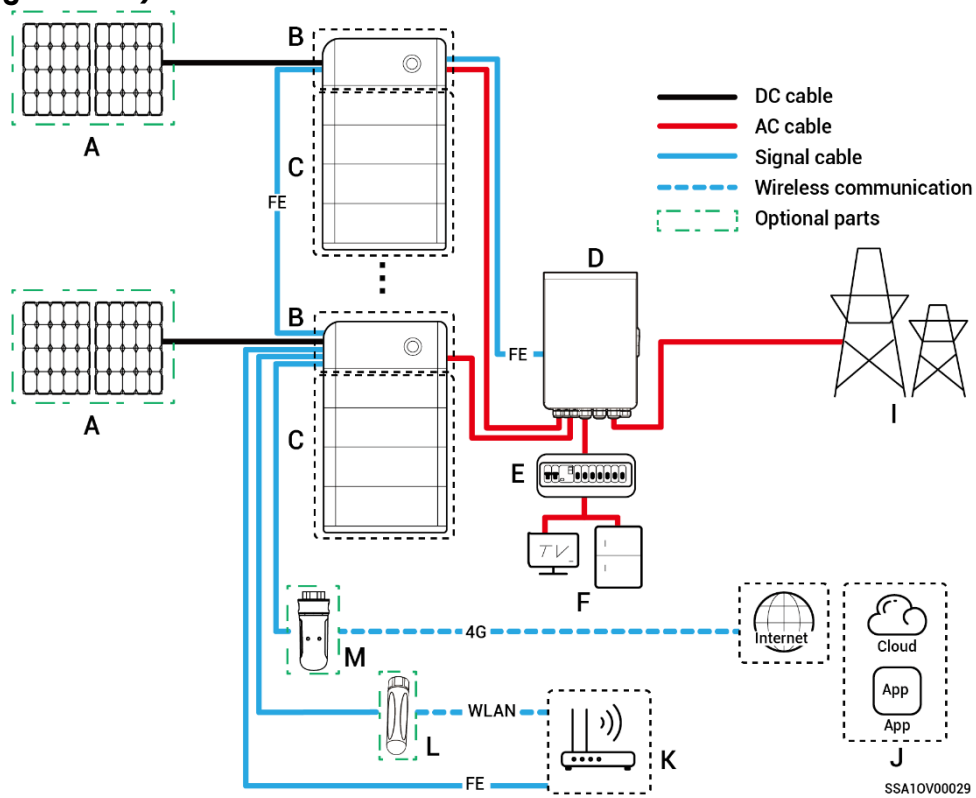

- A.** PV panel **B.** SigenStor EC/ Sigen Hybrid
C. SigenStor BAT **D.** Gateway **E.** Backup Distribution panel
F. Backup Household loads **G.** Diesel generator **H.** Smart loads
I. Power grid **J.** mySigen **K.** Router **L.** Antenna **M.** CommMod

Tips

- If F (backup household load) experiences leakage, it may pose a risk of electric shock. In order to avoid this hazard, a residual current device (RCD) must be installed between the D (Gateway) and the F (backup household load).
- As a backup energy source for long-term off-grid applications, the diesel generator can work in tandem with the Gateway to provide a smooth transition between PV, storage and diesel generation.
- All the power equipment in the owner's home can be connected as smart loads. To ensure that this product maximizes the benefits to users, it is recommended that the high-power equipment be connected as smart loads (Third-party inverter, heat pumps, pool heaters, clothes dryers, etc.), which can be cut off when the energy storage system has low power. Other low-power equipment are connected as household loads (lights, routers, etc.)
- It is recommended to use Fast Ethernet and WLAN for communication with inverters. When free 4G traffic of CommMod runs out, users must top up their accounts or replace an SIM card.

Partial home backup system wiring diagram

Single inverter (Gateway has the circuit breaker for connecting smart load/diesel generator)

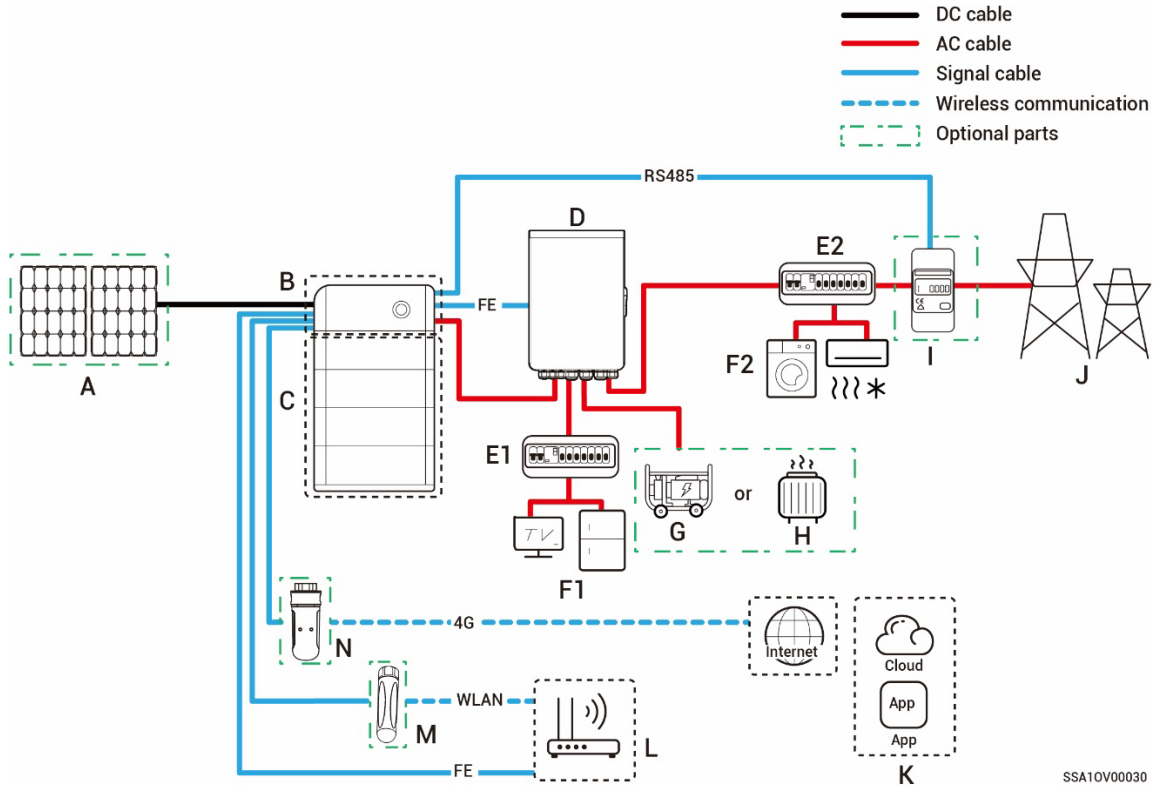

Single inverter (Gateway does not have the circuit breaker connected to the smart load/diesel generator)

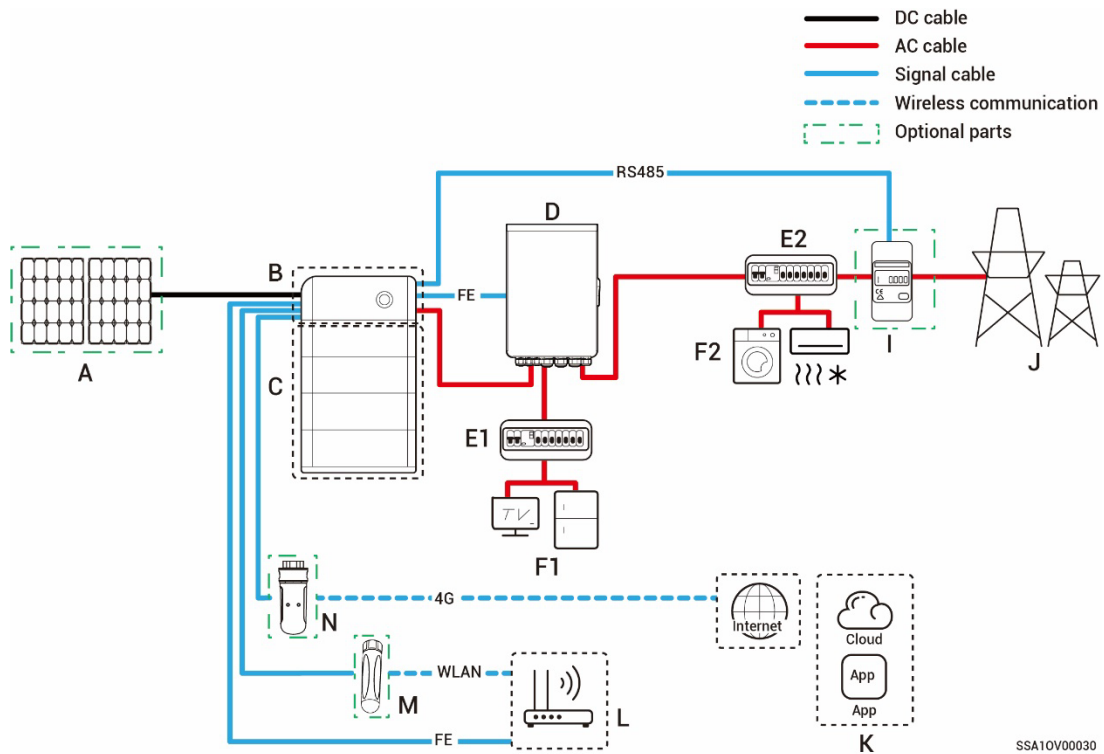

Multiple inverters (Gateway has the circuit breaker for connecting smart load/diesel generator)

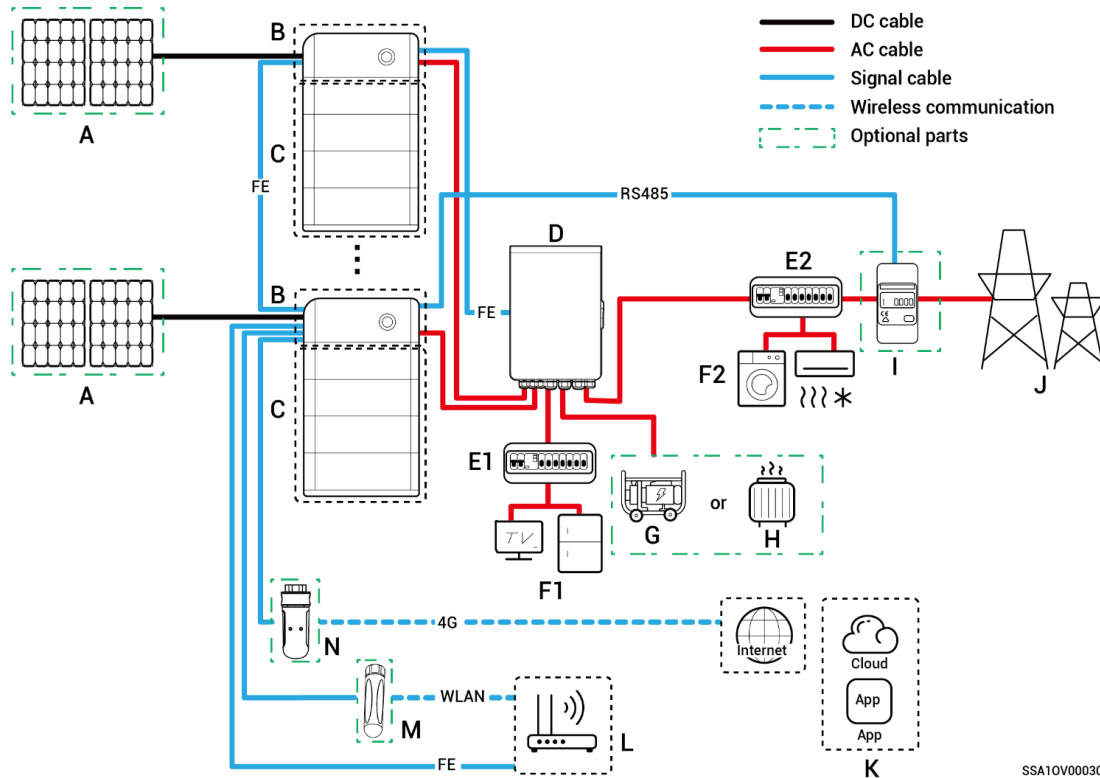

Multiple inverters (Gateway does not have the circuit breaker connected to the smart load/diesel generator)

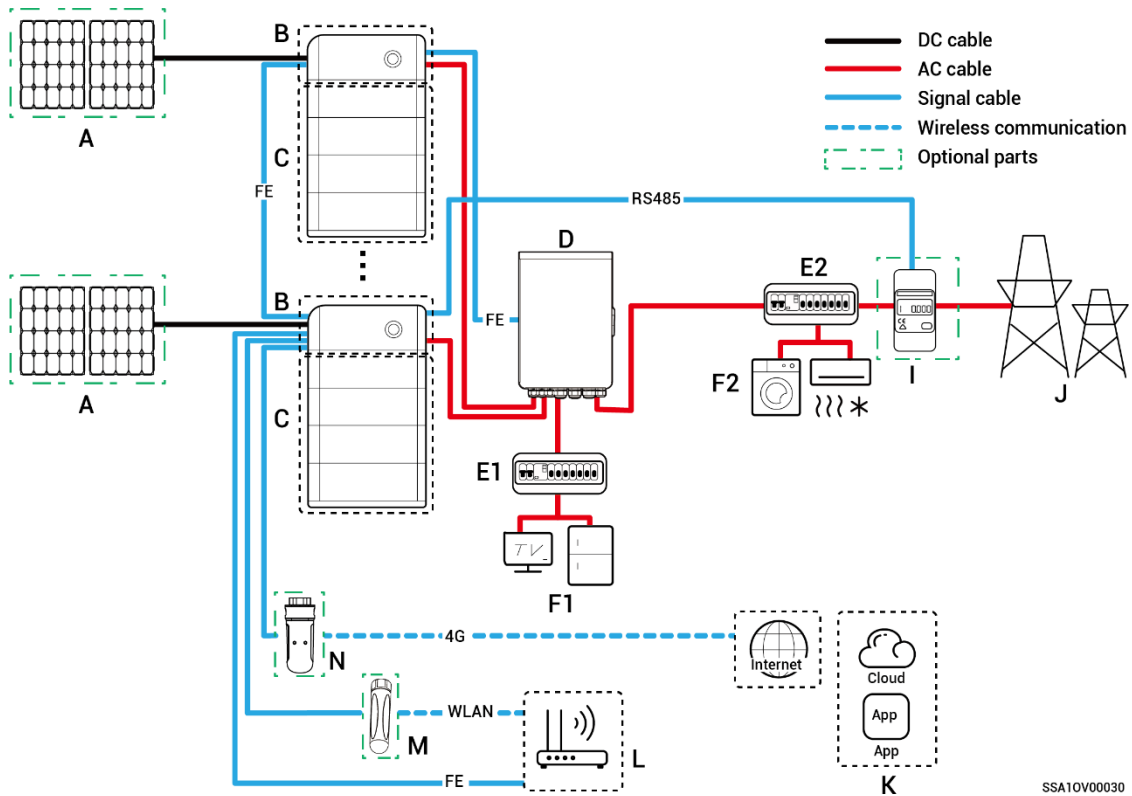

- | | | |
|--|-------------------------------------|--|
| A. PV panel | B. SigenStor EC/Sigen Hybrid | |
| C. SigenStor BAT | D. Gateway | E1. Backup Distribution panel |
| E2. Non-Backup Distribution panel | | F1. Backup Household loads |
| F2. Non-Backup Household loads | | G. Diesel Generator |
| H. Smart loads | I. Power sensor | J. Power grid K. mySigen |
| L. Router | M. Antenna | N. CommMod |

Tips

- If E2 (non-backup distribution panel) features leakage protection, it is recommended that the rated residual operating current be greater than or equal to the number of inverters × 100 mA.
- If F1 (backup household load) experiences leakage, it may pose a risk of electric shock. In order to avoid this hazard, a residual current device (RCD) must be installed between the D (Gateway) and the F1 (backup household load).
- As a backup energy source for long-term off-grid applications, the diesel generator can work in tandem with the Gateway to provide a smooth transition between PV, storage and diesel power generation.
- All the power equipment in the owner's home can be connected as smart loads. To ensure that this product maximizes the benefits to users, it is recommended that the high-power equipment be connected as smart loads (Third-party inverter, heat pumps, pool heaters, clothes dryers, etc.), which can be cut off when the energy storage system has low power. Other low-power equipment are connected as household loads (lights, routers, etc.)
- Power sensor has the function of data acquisition for grid connection points enables zero-power grid connection. For partial home backup system wiring, Power sensor does not need to be configured. For partial backup power and zero-power grid connection control system wiring, Power sensor is configured.

- It is recommended to use Fast Ethernet and WLAN for communication with inverters. When free 4G traffic of CommMod runs out, users must top up their accounts or replace an SIM card.

Chapter 3 Site Selection Requirements

Tips

- **Before installing the equipment, please be sure to carefully read the following installation requirements. The company will not be liable for any functional abnormalities or damages arising from the operation of the equipment if the installation requirements are not followed, even in cases leading to personal safety incidents.**
- **During actual installation, the selection of the installation location should comply with local regulations, firefighting regulations, and other relevant laws. The specific installation location planning should be subject to the installer or engineering, procurement, and construction (EPC) contracts.**

Installation Environment Requirements





- Do not install the equipment in a smoky, flammable, or explosive environment.
- Avoid exposing the equipment to direct sunlight, rain, standing water, snow, or dust. It is suggested to install the equipment in a sheltered place. Take preventive measures in operating areas prone to natural disasters such as floods, mudslides, earthquakes, and typhoons.
- Do not install the equipment in an environment with strong electromagnetic interference.
- The temperature and humidity of the installation environment should meet equipment requirements.
- The equipment should be installed in an area that is at least 500 m away from corrosion sources that may result in salt damage or acid damage. Corrosion sources include but are not limited to seaside, thermal power plants, chemical plants, smelters, coal plants, rubber plants, and electroplating plants.

Installation Position Requirements

- Do not tilt the equipment or place it upside down. Ensure that the equipment is horizontally installed.
- Do not install the equipment in areas easily accessible to children.
- Do not install the equipment in a place with fire hazards or is prone to moisturizing.
- The equipment produces sound when it is operating. Please install the equipment in a place with appropriate distance at which there is no impact to daily work and life.
- Do not install the equipment in a sealed, poorly ventilated location without fire protection measures and inaccessible for firefighters.
- The equipment is hot when it is operating. If the equipment is installed indoors, please ensure good indoor ventilation and avoid significant indoor temperature rise by more than 3°C while the equipment is operating. Otherwise, the equipment will be derated.
- Do not install the equipment in mobile scenarios such as recreational vehicles, cruise ships, and trains.
- It is recommended to install the equipment in a location where you can easily access, install, operate, and maintain it, and view the indicator status.
- Do not place the equipment in the vehicle passage when installed in a garage to avoid collisions.

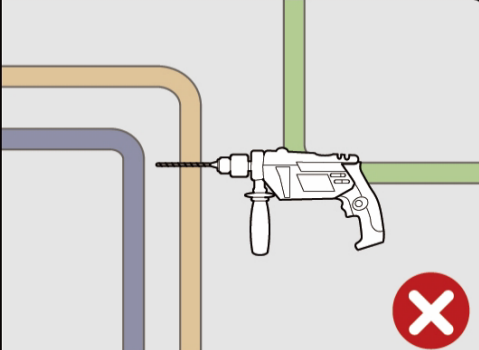
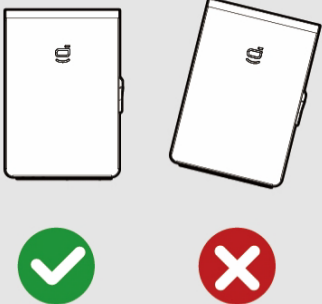
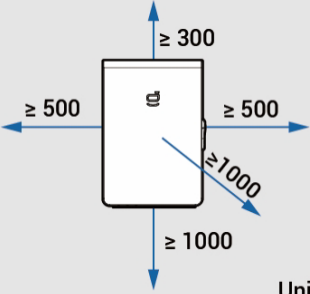
Mounting Surface Requirements

- Do not install the equipment on a flammable base.
- The installation base should meet the load-bearing requirement. Solid brick-concrete structures, concrete walls are recommended.
- The installation base should be flat, and the installation area should meet the installation space requirements.
- No plumbing or electrical alignments are allowed inside the installation base to avoid potential drilling hazards during equipment installation.

			
	 <p style="text-align: right;">Unit: mm</p>		
 <p>Relative humidity 0%RH to 95%RH</p>	 <p>Ambient temperature -30°C to 55°C (The equipment will be derated when the temperature is greater than 35°C)</p>	 <p>Heat source (60°C) distance</p>	 <p>SSA1SF00008</p>

Chapter 4 Equipment Installation and Wiring

- Only company authorized personnel should install and connect the equipment. For more information about Gateway installation and wiring, refer to the respective documentation.
- Parts and accessories supplied with the packing box are personal assets of the owner and must be kept safe.

Chapter 5 mySigen App Query

The App can be downloaded in the following two ways. For details, see **mySigen App User Manual**.



Chapter 6 System Maintenance

Danger

- Do not perform operations on the equipment with power on. Before operation, please make sure all power supplies to the equipment have been disconnected, including but not limited to the grid side, inverter and Generator power switches.
- Do not remove the inner panel. To remove the inner panel, contact your installer or sales representative for assistance.

6.1 Power Off

Warning

- When the equipment is faulty, disconnect all circuit breakers in the equipment immediately, and check and remove the fault before turning it on again.
- Do not operate circuit breakers that are not connected to corresponding equipment when the equipment is powered off. Keep these circuit breakers disconnected.

6.1.1 Sigen Gateway HomeMax SP

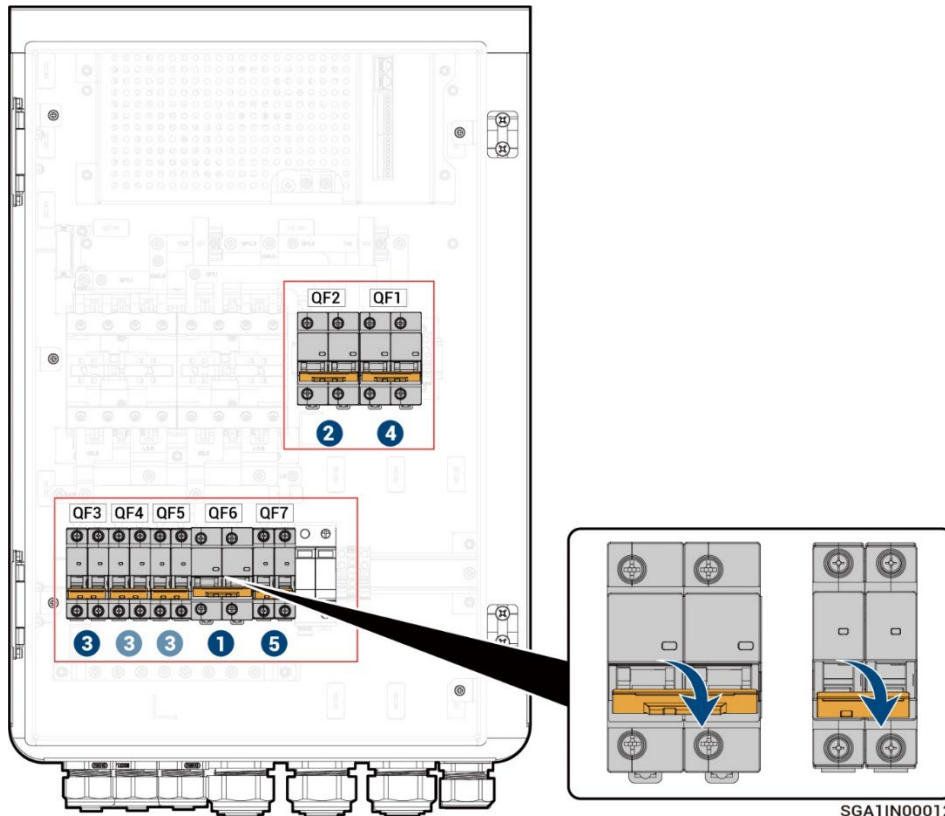

Warning

The Gateway should be disconnected in the following order:

1. Switch off the miniature circuit breaker QF6 (connecting to Backup Household loads).
2. (Optional) Switch off the miniature circuit breaker QF2 (connecting to Generator/ Smart load).
3. After shutting down the inverter, switch off the miniature circuit breakers QF3 or QF4 or QF5 (connecting to Inverter).
4. Switch off the miniature circuit breaker QF1 (connecting to Power grid).
5. Switch off the surge protective device switch QF7.

6.1.2 Sigen Gateway Home SP

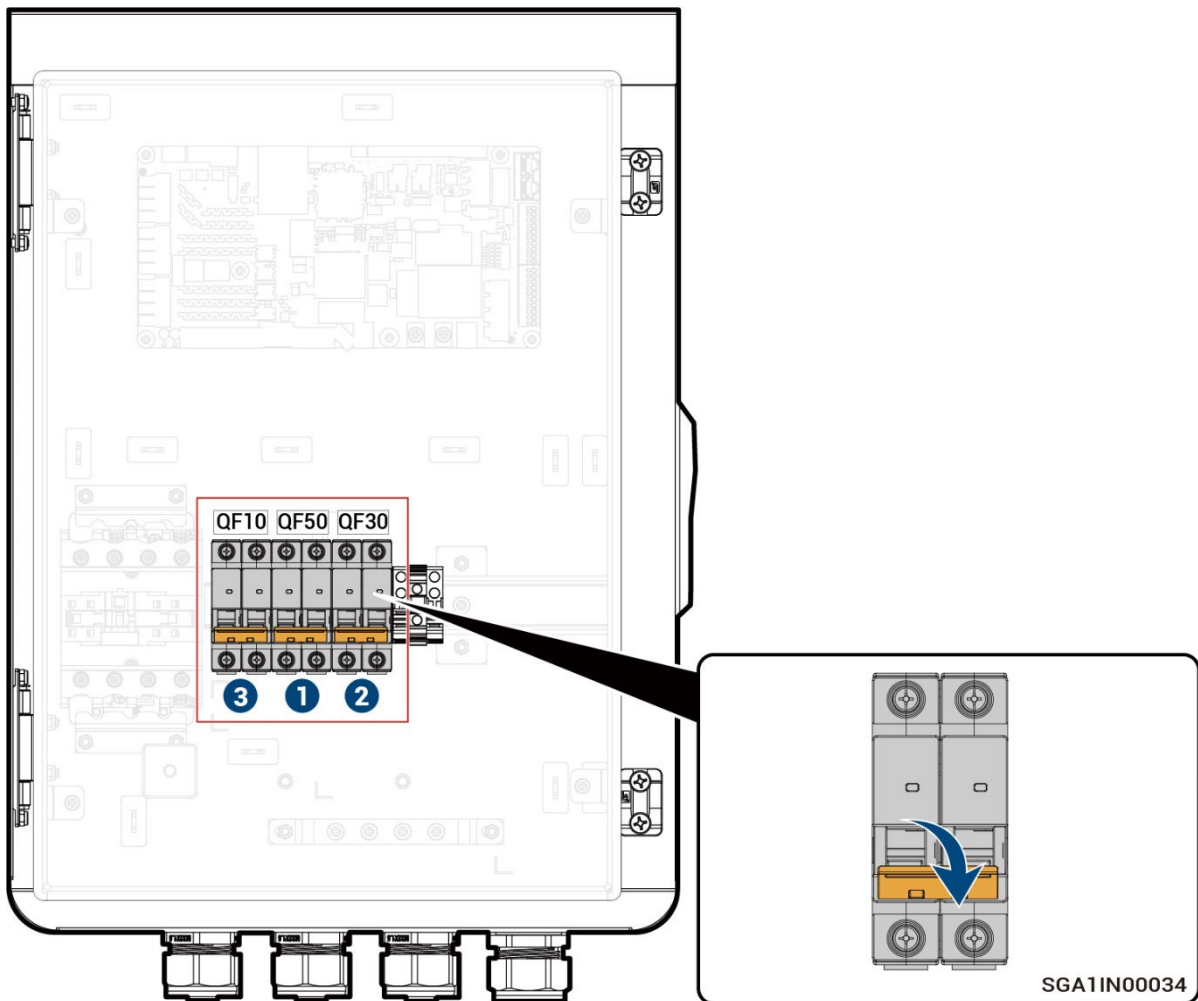

Warning

The Gateway should be disconnected in the following order:

1. Switch off the miniature circuit breaker QF50 (connecting to Backup Household loads).
2. After shutting down the inverter, switch off the miniature circuit breaker QF30 (connecting to Inverter).
3. Switch off the miniature circuit breaker QF10 (connecting to Power grid).

6.1.3 Sigen Gateway Home SP 12K

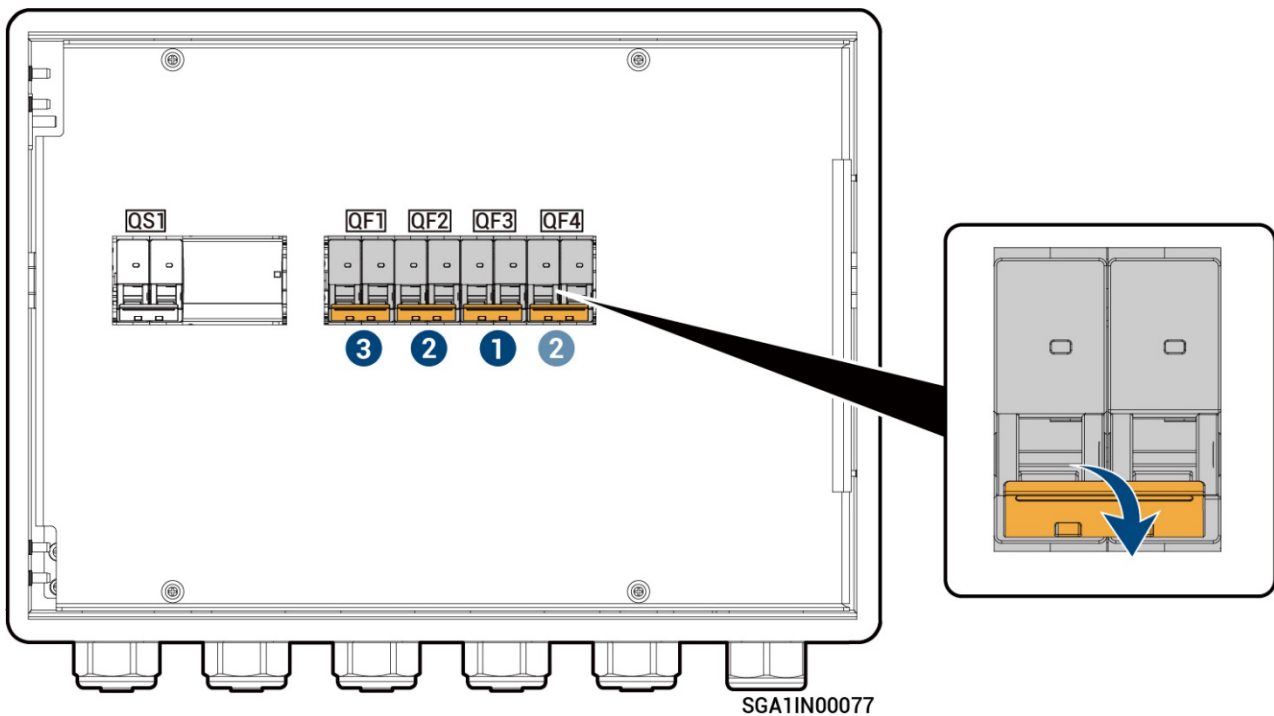

Warning

The Gateway should be disconnected in the following order:

1. Switch off the miniature circuit breaker QF3 (connecting to Backup Household loads).
2. After shutting down the inverter, switch off the miniature circuit breaker QF2 or QF4 (connecting to Inverter).
3. Switch off the miniature circuit breaker QF1 (connecting to Power grid).

6.1.4 Sigen Gateway SP AU

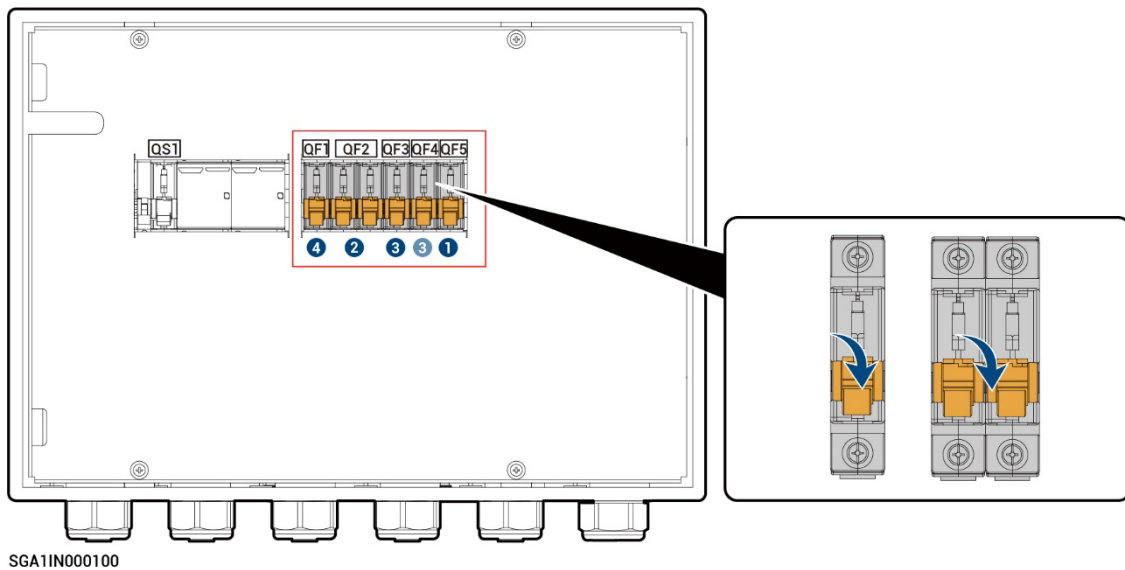

Warning

The Gateway should be disconnected in the following order:

1. Switch off the miniature circuit breaker QF5 (connecting to Backup Household loads).
2. (Optional) Switch off the miniature circuit breaker QF2 (connecting to Generator/ Smart load).
3. After shutting down the inverter, switch off the miniature circuit breaker QF3 or QF4 (connecting to Inverter).
4. Switch off the miniature circuit breaker QF1 (connecting to Power grid).

6.1.5 Sigen Gateway HomeMax SP LA

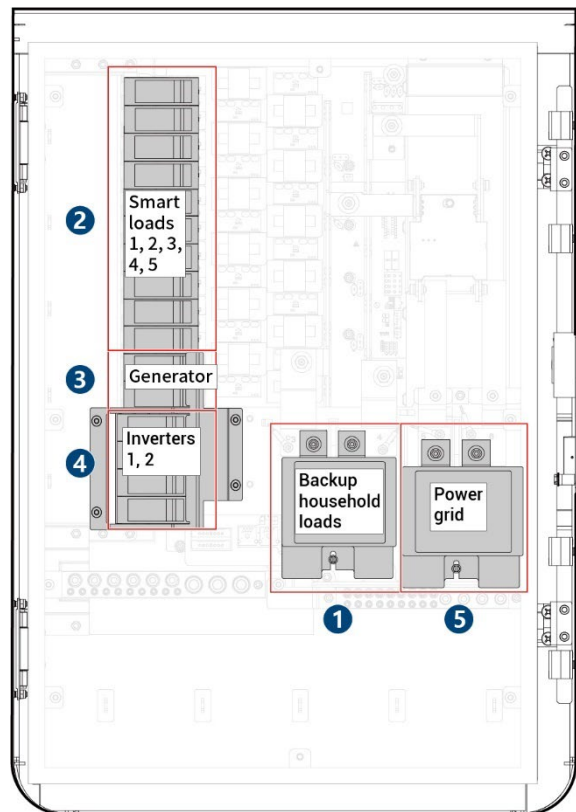

Warning

The Gateway should be disconnected in the following order:

1. Switch off the miniature circuit breaker (connecting to Backup Household loads).
2. Switch off the miniature circuit breaker (connecting to Smart load).
3. (Optional) Switch off the miniature circuit breaker (connecting to Generator).
4. After shutting down the inverter, switch off the miniature circuit breakers (connecting to Inverter).
5. Switch off the miniature circuit breaker (connecting to Power grid).

6.1.6 Sigen Gateway HomeMax TP

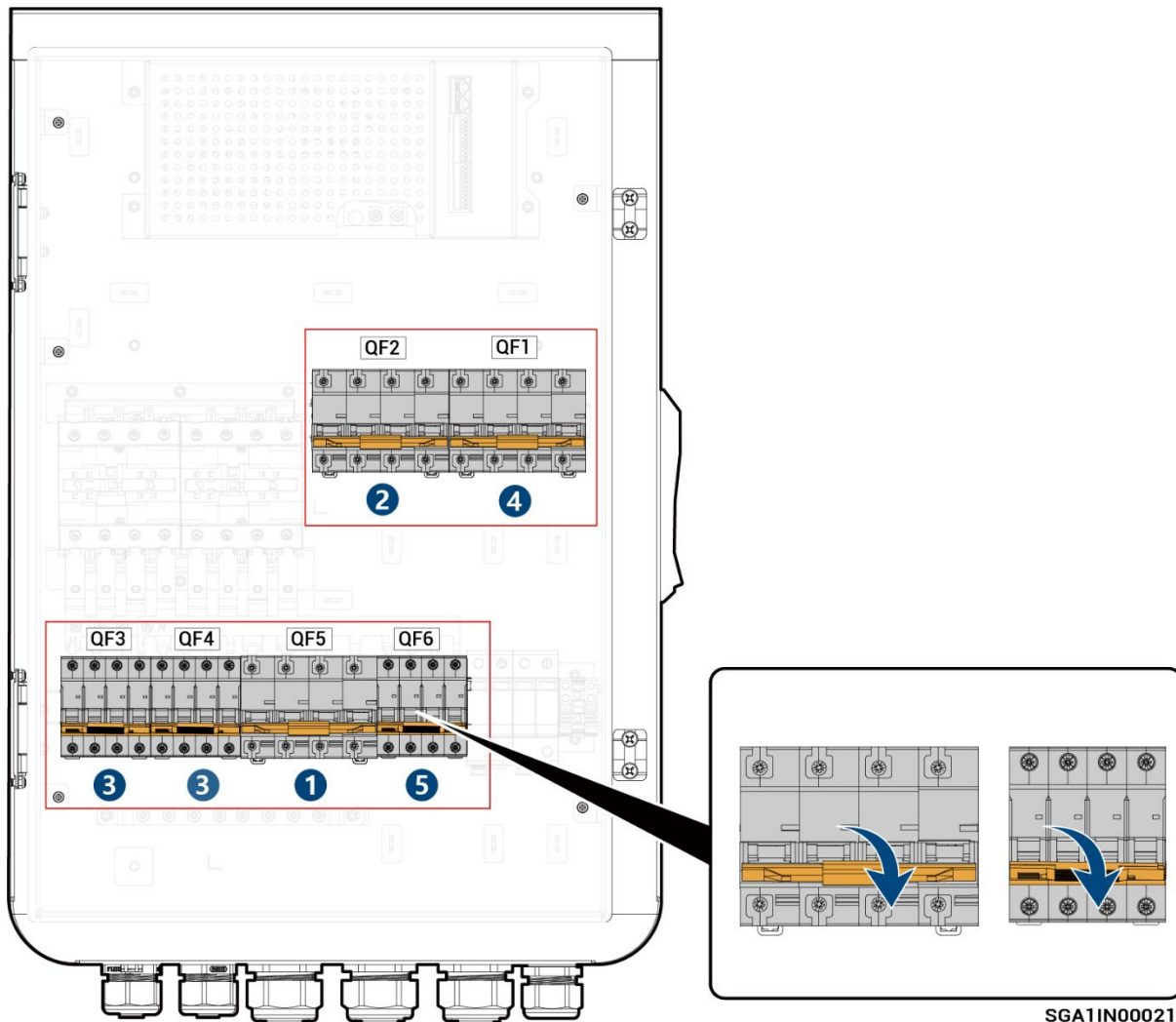

Warning

The Gateway should be disconnected in the following order:

1. Switch off the miniature circuit breaker QF5 (connecting to Backup Household loads).
2. (Optional) Switch off the miniature circuit breaker QF2 (connecting to Generator/Smart load).
3. After shutting down the inverter, switch off the miniature circuit breaker QF3 or QF4 (connecting to Inverter).
4. Switch off the miniature circuit breaker QF1 (connecting to Power grid).
5. Switch off the surge protective device switch QF6.

6.1.7 Sigen Gateway Home TP

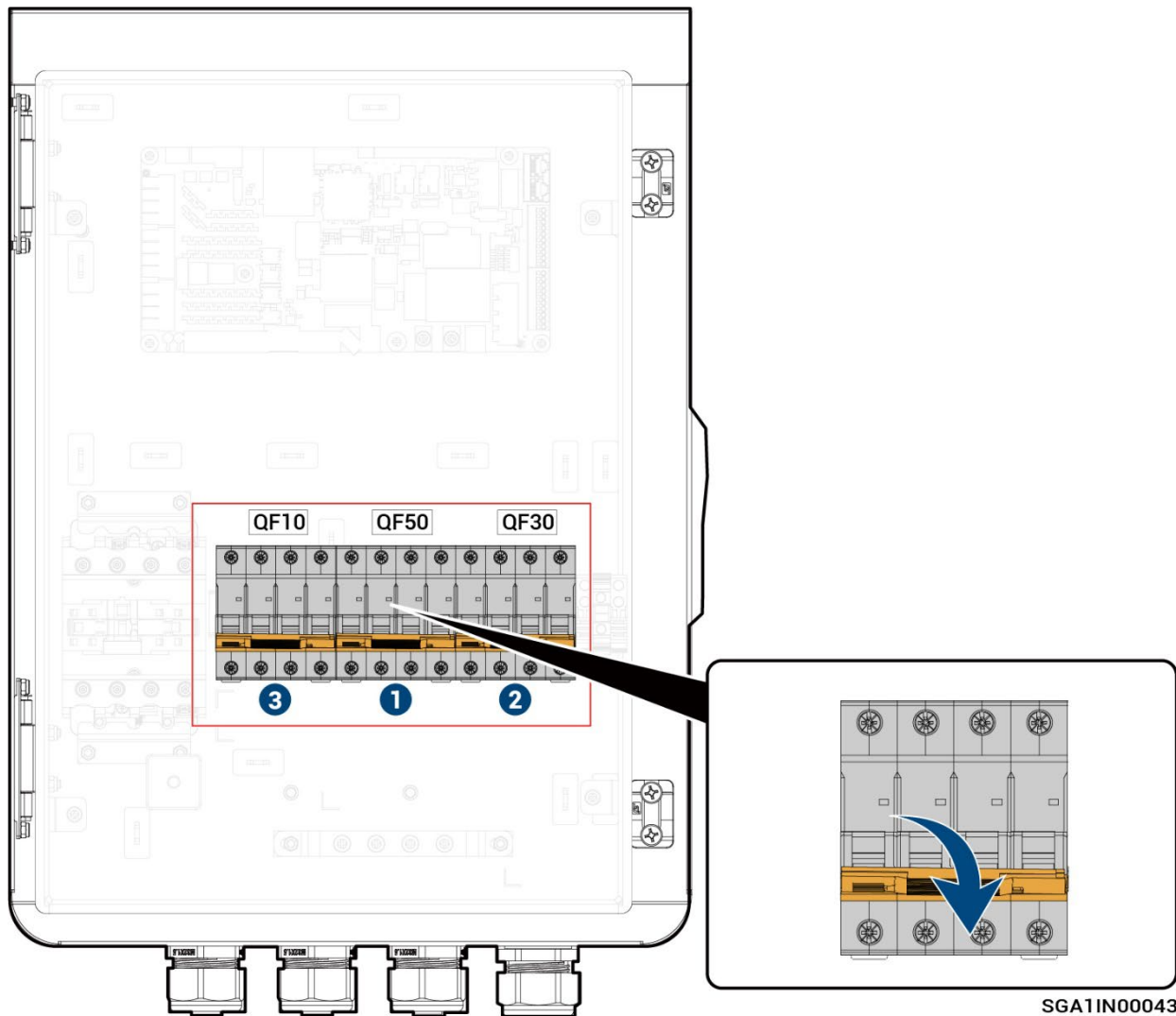

SGA11N00043

Warning

The Gateway should be disconnected in the following order:

1. Switch off the miniature circuit breaker QF50 (connecting to Backup Household loads).
2. After shutting down the inverter, switch off the miniature circuit breaker QF30 (connecting to Inverter).
3. Switch off the miniature circuit breaker QF10 (connecting to Power grid).

6.1.8 Sigen Gateway (TP AU, HomeMax TP CN)

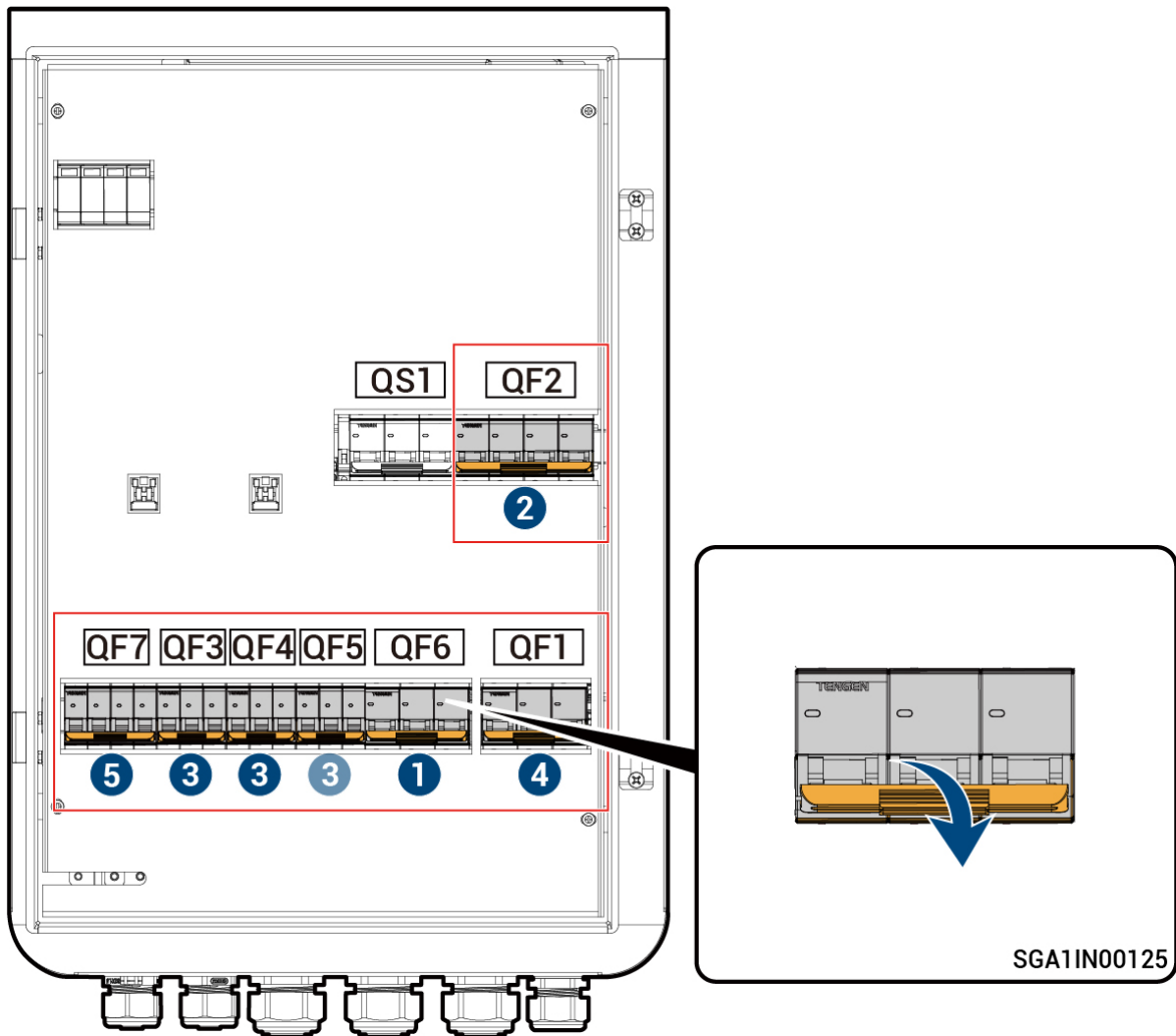

Warning

The Gateway should be disconnected in the following order:

1. Switch off the miniature circuit breaker QF6 (connecting to Backup Household loads).
2. (Optional) Switch off the miniature circuit breaker QF2 (connecting to Generator/Smart load).
3. After shutting down the inverter, switch off the miniature circuit breaker QF3 or QF4 or QF5 (connecting to Inverter).
4. Switch off the miniature circuit breaker QF1 (connecting to Power grid).
5. Switch off the surge protective device switch QF7.

6.1.9 Sigen Gateway Home TP (30K, 30K CN)

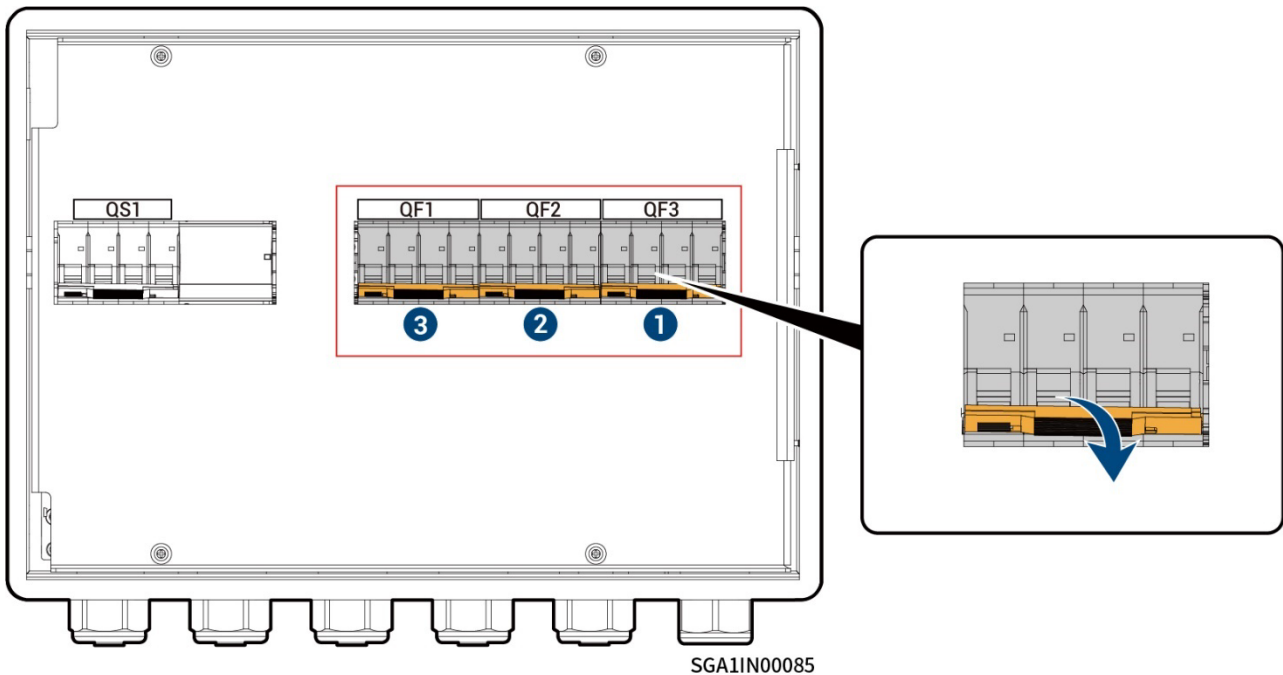

Warning

The Gateway should be disconnected in the following order:

1. Switch off the miniature circuit breaker QF3 (connecting to Backup Household loads).
2. After shutting down the inverter, switch off the miniature circuit breaker QF2 (connecting to Inverter).
3. Switch off the miniature circuit breaker QF1 (connecting to Power grid).

6.1.10 Sigen Gateway HomePro TP

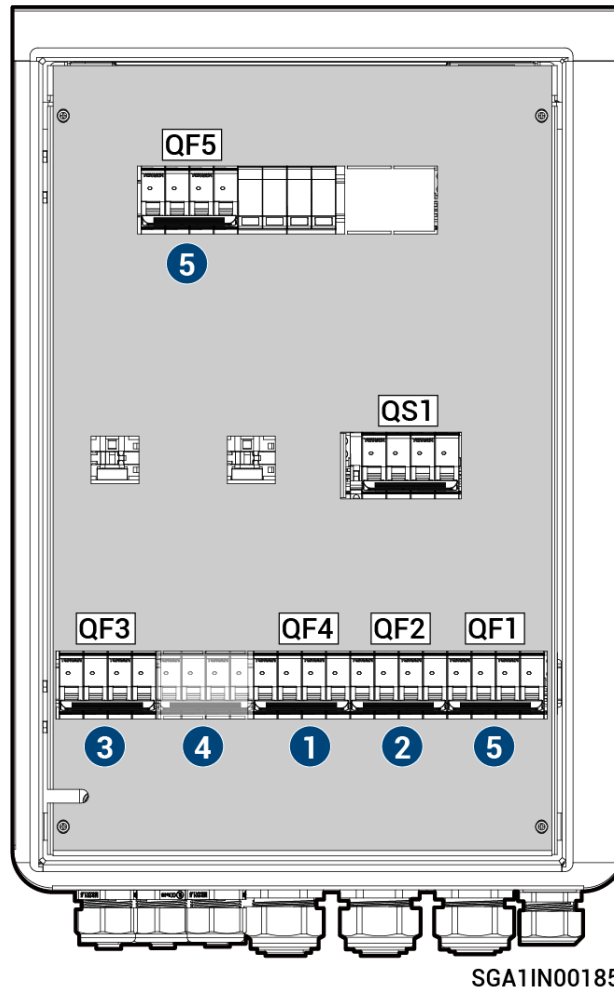

Warning

The Gateway should be disconnected in the following order:

1. Switch off the miniature circuit breaker QF4 (connecting to Backup Household loads).
2. (Optional) Switch off the miniature circuit breaker QF2 (connecting to Generator/Smart load).
3. After shutting down the inverter, switch off the miniature circuit breaker QF3 (connecting to Inverter 1).
4. (Optional) If installing a self-supplied circuit breaker, you can switch off the miniature circuit breaker (connecting to Inverter 2).
5. Switch off the miniature circuit breaker QF1 (connecting to Power grid).
6. Switch off the surge protective device switch QF5.

6.1.11 Sigen Gateway HomePro TP-L

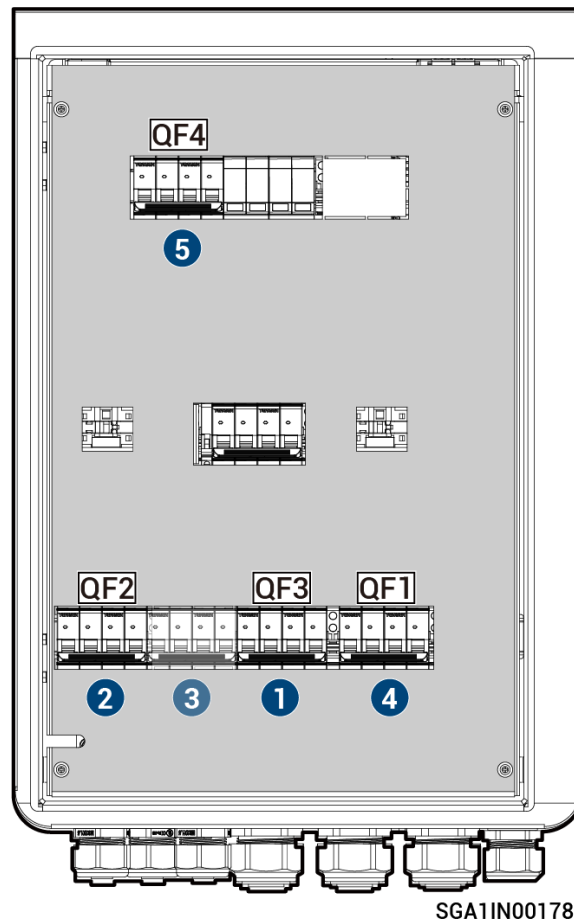

Warning

The Gateway should be disconnected in the following order:

1. Switch off the miniature circuit breaker QF3 (connecting to Backup Household loads).
2. Switch off the miniature circuit breaker QF2 (connecting to Inverter 1).
3. (Optional) If installing a self-supplied circuit breaker, you can switch off the miniature circuit breaker (connecting to Inverter 2).
4. Switch off the miniature circuit breaker QF1 (connecting to Power grid).
5. Switch off the miniature circuit breaker QF4.

6.2 Routine Maintenance

To ensure the long-term operating of the equipment, you are advised to perform routine maintenance according to this section.

 **Danger**

To remove the inner panel, ask a professional for evaluation before proceeding.

Inspection Items	Inspection Method	Power Off or Not	Maintenance Interval
System cleaning	Check the device regularly for shielding and dirt. If so, clean it up. Do not use tools that may cause electric shock or insulation damage, such as wire brushes and during the cleaning process.	Yes	Once every 3 months
System operating state	<ul style="list-style-type: none"> ● Check whether the equipment appearance is damaged or deformed. ● Check for noise when the equipment is operating. ● Check whether the equipment parameters are correctly set when the equipment is operating. 	No	Once every 6 months
Electrical connection	<ul style="list-style-type: none"> ● Check whether cable terminals are tightly connected. ● Check whether cable sheath is damaged. 	Yes	Check once every 6 months after creating new systems and once

	<ul style="list-style-type: none"> ● Check whether scratches exist on the surface where the cable contacts the metal. ● Check whether unused routing holes are sealed. ● Check whether all screws on the device are loose. 		every 6 to 12 months thereafter.
Grounding reliability	Check whether the ground cable is properly and reliably connected.	No	Check once every 6 months after creating new systems and once every 6 to 12 months thereafter.

6.3 Troubleshooting

Fault	Cause analysis	Corrective action
The SigenStor shuts down/restarts repeatedly in off-grid mode.	The backup load is greater than the rated power of the SigenStor.	Turn off part of household loads to ensure the load is lower than the rated power of the SigenStor.
	The bypass switch is turned on by mistake.	Turn off the bypass switch.

6.4 Operations on Bypass Switch

Tips

In normal cases, the bypass switch is turned off. Do not operate the bypass switch. In this case, the Gateway can automatically switch between on-grid and off-grid.

6.4.1 Bypass switch closing procedure

Tips

When abnormal operation of the Gateway's grid contactor prevents power supply to the load, close the bypass switch to directly power the load from the grid.

1. Check that the grid normally supplies power.
2. Power off by referring to 6.1 Power Off.
3. Refer to the delay time as instructed on the label on the equipment and wait for the specified time. Once the time has elapsed, remove the retaining ring from the bypass switch and turn on the bypass switch.

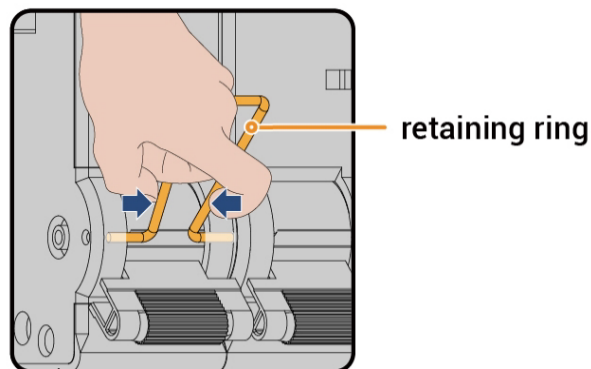

SGA1IN00153

Warning

- There is residual current and the equipment is hot immediately after the equipment is powered off. Operating the equipment immediately upon power off may lead to electric shock or burns.
- High voltage exists in the equipment. Wear insulating gloves when turning on the switch.

Caution

After turning on the bypass switch, do not turn on the miniature circuit breaker connected to the inverter and Generator on Gateway. Otherwise, the power grid port will be charged, resulting in the risk of electric shock.

4. Turn on the miniature circuit breaker connected to the SPD.
5. Turn on the miniature circuit breaker connected to the power grid.
6. Turn on the miniature circuit breaker connected to backup household loads.
7. Close the equipment door.

6.4.2 Bypass switch opening procedure

Tips

If accidental bypass switch closure occurs, open the bypass switch and then power up both the inverter and backup power cabinet.

1. Troubleshoot and repair the fault.
2. Open the bypass switch.
3. Refer to the maintenance guide for the specific inverter model to complete the inverter power-up procedure.
4. Refer to the installation guide for the specific Gateway model to complete the power-up procedure.

6.5 Emergency Treatment

Emergency Measures for Fire

 **Danger**

- Please shut down the equipment or disconnect the main power switch when it is safe.
- If the fire is small, use carbon dioxide or ABC dry powder extinguisher to extinguish the fire.
- If the fire is spreading, evacuate the building or equipment area immediately and call the fire department. Re-entry to burning buildings is prohibited.
- Do not contact with high voltage components during fire fighting, otherwise it may lead to the risk of electric shock.
- After extinguishing the fire, do not use the equipment, please contact your installer or sales representative.

Emergency Measures for Flood

 **Danger**

- Please shut down the equipment or disconnect the main power switch when it is safe.
- After the flood waters recede, do not use the equipment. Please contact your installer or sales representative.

Chapter 7 Appendix

7.1 Technical Parameter

For details about equipment parameters, see the Data sheets of the product.