

# SigenStor Home Installation Guide

Three-phase System  
A1

Version: 11  
Release date: 2026-02-05





S/N	Equipment/component	Model/version	Function specification
A	PV module	–	–
B	SigenStor EC	SigenStor EC 5.0/6.0/8.0/10.0/12.0/15.0/17.0/20.0/25.0/30.0 TP	Inverter; it can be used in photovoltaic energy storage scenarios and needs to be used together with PV modules and SigenStor BAT.
	Sigen Hybrid	Sigen Hybrid 5.0/6.0/8.0/10.0/12.0/15.0/17.0/20.0/25.0/30.0 TP	Inverter; it can be used in conjunction with PV modules for pure PV applications or in combination with PV modules and SigenStor BAT for photovoltaic storage systems after the purchase and activation of a license.
C	SigenStor BAT	SigenStor BAT 5.0/6.0/8.0/10.0	Battery pack; it can store electric energy. Supports multiple models of battery packs to be used together.
D	AC switch	–	The rated voltage of the AC switch connected to each inverter should be $\geq 380$ V a.c., and the rated current is recommended: <ul style="list-style-type: none"> <li>• SigenStor EC/Sigen Hybrid (5.0–8.0) TP: The rated current is 25 A</li> <li>• SigenStor EC/Sigen Hybrid (10.0–15.0) TP: The rated current is 32 A</li> <li>• SigenStor EC/Sigen Hybrid (17.0–20.0) TP: The rated current is 40 A</li> <li>• SigenStor EC/Sigen Hybrid 25.0 TP: The rated current is 50 A</li> <li>• SigenStor EC/Sigen Hybrid 30.0 TP: The rated current is 63 A</li> </ul>
E	Gateway	Gateway Three-phase Series Products	It's applicable for PV storage and pure storage applications to facilitate data acquisition and monitoring, off-grid backup power switching, diesel generator control, energy management; it must be used with SigenStor BAT and inverter. Gateway is a must-have for backup system wiring; for partial backup power and zero-power grid connection control system wiring, the Gateway and power sensor must be arranged.
F	Household loads	–	<ul style="list-style-type: none"> <li>• In a backup system wiring, F1 represents the backup household loads, and F2 represents the non-backup household loads.</li> <li>• If the backup household load experiences leakage, it may pose a risk of electric shock. In order to avoid the risk of this hazard, a residual current device (RCD) must be installed between the Gateway and the backup household load.</li> </ul>

S/N	Equipment/component	Model/version	Function specification
G	Distribution panel	–	<ul style="list-style-type: none"> <li>In backup system wiring, G1 is the backup distribution panel, and G2 is the non-backup distribution panel. If the non-backup distribution panel features leakage protection, it is recommended that the rated residual operating current be greater than or equal to the number of inverters × 100 mA.</li> <li>In non-backup system wiring, if the distribution panel features leakage protection, it is recommended that the rated residual operating current be greater than or equal to the number of inverters × 100 mA.</li> <li>The rated voltage of the AC switch of the distribution panel should be not less than 380 V a.c., And the rated current is recommended: that is, not less than the maximum output current of an inverter × the number of inverters in parallel connection × 1.25<sup>[1]</sup>.</li> </ul>
H	Diesel generator	–	As a backup energy source for long-term off-grid applications, it can work in tandem with the Gateway to provide a smooth transition between PV, storage and diesel generation.
I	Smart loads	–	All the power equipment in the owner's home can be connected as smart loads. To ensure that this product maximizes the benefits to users, it is recommended that the high-power equipment be connected as smart loads (third part inverter, heat pumps, pool heaters, clothes dryers, etc.), which can be cut off when the energy storage system has low power. Other low-power equipment are connected as household loads (lights, routers, etc.)
J	Power sensor	Sigen Sensor TP-DH (SDM630MODBUS V2) Sigen Sensor TP-CT120-DH (SDM630MCT 40mA/120A) Sigen Sensor TP-CT300-DH (SDM630MCT 40mA/300A) Sigen Sensor TP-CT600-DH (SDM630MCT V2/600A)	Data acquisition for grid connection points enables zero-power grid connection.

Note [1]: The maximum output current of an inverter can be found in its respective data sheet.

S/N	Equipment/component	Model/version	Function specification
K	Power grid	–	–
L	App	mySigen	Android 6.0 or later iOS 12.0 onwards
M	Router	–	To be used for FE/WLAN communication.
N	Antenna	–	To be used for WLAN communication.
O	Communication module	Sigen CommMod	To be used for 4G communication.

## Tips

- When configuring the Gateway, refer to the Installation Guide of the respective Gateway model for detailed installation procedures.
- When adding a Sigen EV DC Charging Module, refer to the Installation Guide of the respective Sigen EV DC Charging Module model for detailed installation procedures.

## 1.2 Appearance and Dimensions

Inverter and battery pack

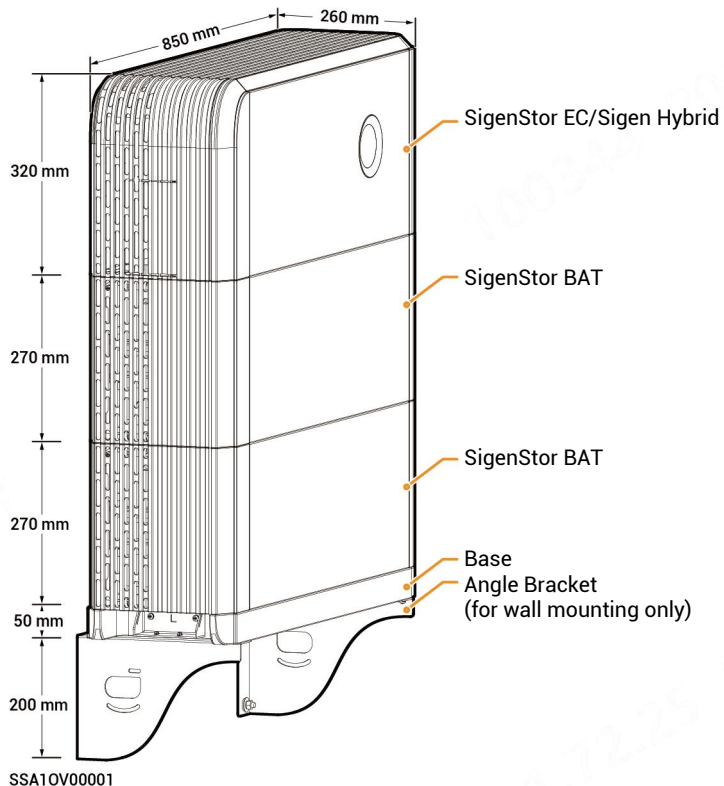

## 1.3 Port Descriptions

SigneStor EC / Signe Hybrid Left View

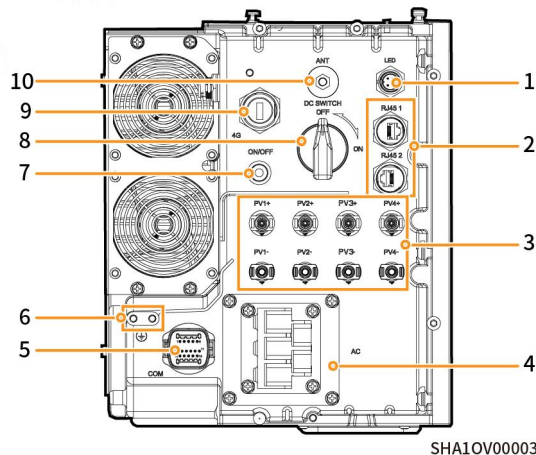

S/N	Name	Marking
1	Decorative cover light strip connector	LED
2	Network interface	RJ45 1/ RJ45 2
3	DC input interface	PV1+ / PV2+ / PV3+ / PV4+ / PV1- / PV2- / PV3- / PV4-
4	AC output interface	AC
5	Communication interface	COM
6	Ground screw	-
7	Switch button	ON/OFF
8	DC switch	DC SWITCH
9	Signe CommMod interface	4G
10	Antenna interface	ANT

## 2 Pre-installation Check

- Check whether the components are entirely supplied against the packing list and whether the appearance is in good condition. For any problem, contact your sales representative.
- Parts and accessories supplied with the packing box are personal assets of the owner and must not be taken away from the installation site.
- Check personal protective equipment and installation tools to ensure that they are complete; if not, please make them up.
- Check the user-supplied cables to ensure the quantity and specifications are correct; if not, make new preparations.

### Protective equipment



Safety hat



Goggles



Dust mask



Protective gloves



Insulating gloves



Insulating shoes

### Installation tool



Tape measure

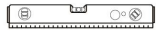

Level



Marker

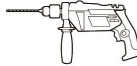

Power drill



Rubber mallet



Crimping pliers



Wire stripper



Scissors



Cable tie



Vacuum cleaner

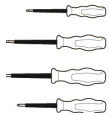

Insulation screwdriver set

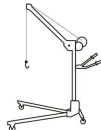

(Optional) Lift  
(used when SigenStor  
BAT  $\geq 3$  units)



(Optional) Stainless steel covered plastic steel rope (bearing:  $\geq 250$  kg Diameter: 3 mm)



Insulation sleeve set



Torque socket wrench



(Optional) Lock  
(Lock bar diameter  $\leq 5$  mm)



Adjustable torque wrench for external hexagon bolts



hexagonal L-type wrench (4 mm on opposite side)



Open-end wrench (model: H4TW0001  
Manufacturer: Amphenol)



Crimping pliers (model: H4TC0003  
Manufacturer: Amphenol)

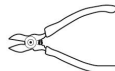

Wire cutter

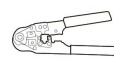

Network cable pliers



Heat gun



Heat shrinkable sleeve

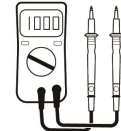

Multimeter

**Caution**

- The specifications of the Installer-provided cable must comply with the cable regulations and standards of the country or region standards.
- L1, L2, L3, N and PE should be connected to other equipment in sequence without mixing.

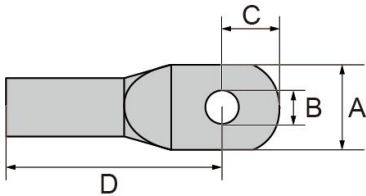
S/N	Cable name	Recommended specifications										
1	Protective ground cable	<p>Outdoors single core copper flexible cable</p> <ul style="list-style-type: none"> <li>• SigenStor EC / Sigen Hybrid (5.0–15.0) TP: Cross-sectional area of core conductor: 4–6 mm<sup>2</sup></li> <li>• SigenStor EC / Sigen Hybrid (17.0–20.0) TP: Cross-sectional area of core conductor: 6–10 mm<sup>2</sup></li> <li>• SigenStor EC / Sigen Hybrid 25.0 TP: Cross-sectional area of core conductor: 10–16 mm<sup>2</sup></li> <li>• SigenStor EC / Sigen Hybrid 30.0 TP: Cross-sectional area of core conductor: 16 mm<sup>2</sup></li> </ul>										
2	AC cable	<p>Outdoors five-core copper flexible cable (L1, L2, L3, N, PE)</p> <ul style="list-style-type: none"> <li>• SigenStor EC / Sigen Hybrid (5.0–15.0) TP: Cross-sectional area of core conductor: 4–6 mm<sup>2</sup>; Outer diameter: 10–21 mm</li> <li>• SigenStor EC / Sigen Hybrid (17.0–20.0) TP: Cross-sectional area of core conductor: 6–10 mm<sup>2</sup>; Outer diameter: 19–22 mm</li> <li>• SigenStor EC / Sigen Hybrid 25.0 TP: Cross-sectional area of core conductor: 10–16 mm<sup>2</sup>; Outer diameter: 22–25 mm</li> <li>• SigenStor EC / Sigen Hybrid 30.0 TP: Cross-sectional area of core conductor: 16 mm<sup>2</sup>; Outer diameter: 22–25 mm</li> </ul> <p>Requirements for M5 OT/DT Terminal: Please purchase the OT/DT terminals according to the following requirements.</p> <table border="1" style="display: inline-table; vertical-align: top;"> <thead> <tr> <th>Item</th> <th>Description</th> </tr> </thead> <tbody> <tr> <td>A</td> <td>≤ 15 mm</td> </tr> <tr> <td>B</td> <td>5.3–5.5 mm</td> </tr> <tr> <td>C</td> <td>≤ 7.5 mm</td> </tr> <tr> <td>D</td> <td>≤ 26 mm</td> </tr> </tbody> </table> 	Item	Description	A	≤ 15 mm	B	5.3–5.5 mm	C	≤ 7.5 mm	D	≤ 26 mm
Item	Description											
A	≤ 15 mm											
B	5.3–5.5 mm											
C	≤ 7.5 mm											
D	≤ 26 mm											

S/N	Cable name	Recommended specifications
3	Signal cable	Outdoor two-core shielded twisted pair Cross-sectional area of core conductor: 0.5–0.75 mm <sup>2</sup> (multi-core flexible conductor, Tubular terminal needed) 0.5–1 mm <sup>2</sup> (single-strand hard conductor, no tubular terminal needed) Outer diameter: 4.5–6.5 mm Cable length: ≤ 1000 m Baud rate: ≤ 9600 bps
4	Network cable	Outdoor eight-conductor shielded twin-twisted pair cable Cross-sectional area of conductor: 0.13-0.2 mm <sup>2</sup> Outer diameter: 4–7.5 mm Single cable length: ≤ 100 m <sup>[1]</sup>
5	DC cable	Outdoor photovoltaic copper flexible cable <sup>[2]</sup> Cross-sectional area of core conductor: 4–6 mm <sup>2</sup> Outer diameter: 4.5–7.8 mm

Note [1]: The cable length should be limited for good communication. Too long cable degrades the communication effect.

Note [2]: To avoid accidents, aluminum-core cables are strictly prohibited for DC cable.

## Tips

Recommended specifications for cables connecting power sensors to Distribution panel and to the grid, as well as step-by-step instructions for wiring, can be found in the accompanying documentation for each respective model.

## 3 Site Requirements

### Tips

- **Before installing the equipment, please be sure to carefully read the following installation requirements. The company will not be liable for any functional abnormalities or damages arising from the operation of the equipment if the installation requirements are not followed, even in cases leading to personal safety incidents.**
- **During actual installation, the selection of the installation location should comply with local regulations, firefighting regulations, and other relevant laws. The specific installation location planning should be subject to the installer or engineering, procurement, and construction (EPC) contracts.**
- **The equipment can be installed indoors and outdoors. Install the equipment in strict accordance with installation instructions given in this section and local laws and regulations.**

### Installation Environment

- Do not install the equipment in a smoky, flammable, or explosive environment.
- Avoid exposing the equipment to direct sunlight, rain, standing water, snow, or dust. It is suggested to install the equipment in a sheltered place. Take preventive measures in operating areas prone to natural disasters such as floods, mudslides, earthquakes, and typhoons.
- Do not install the equipment in an environment with strong electromagnetic interference.
- The temperature and humidity of the installation environment should meet equipment requirements.
- The equipment should be installed in an area that is at least 500 m away from corrosion sources that may result in salt damage or acid damage. Corrosion sources include but are not limited to seaside, thermal power plants, chemical plants, smelters, coal plants, rubber plants, and electroplating plants.
- In areas with good marine environments (such as Norway, where the nearshore salinity is  $\leq 28$  psu), the mounting distance of the device from the coastline can be appropriately relaxed to  $\geq 200$  m.
- If the outer surface of the device is damaged, please repaint the device in time.

### Installation Location

- Do not tilt the equipment or place it upside down. Ensure that the equipment is horizontally installed.
- Do not install the equipment in areas easily accessible to children.
- Do not install the equipment in a place with fire hazards or is prone to moisturizing.
- The equipment produces sound when it is operating. Please install the equipment in a place with appropriate distance at which there is no impact to daily work and life.
- Do not install the equipment in a sealed, poorly ventilated location without fire protection measures and inaccessible for firefighters.
- The equipment is hot when it is operating. If the equipment is installed indoors, please ensure good indoor ventilation and avoid significant indoor temperature rise by more than  $3^{\circ}\text{C}$  while the equipment is operating. Otherwise, the equipment will be derated.
- Do not install the equipment in mobile scenarios such as recreational vehicles, cruise ships, and trains.
- It is recommended to install the equipment in a location where you can easily access, install, operate, and maintain it, and view the indicator status.
- Do not place the equipment in the vehicle passage when installed in a garage to avoid collisions.

## Installation Base

- Do not install the equipment on a flammable base.
- The installation base should meet the load-bearing requirement. Solid brick-concrete structures, concrete walls, and floors are recommended.
- The installation base should be flat, and the installation area should meet the installation space requirements.
- No plumbing or electrical alignments are allowed inside the installation base to avoid potential drilling hazards during equipment installation.
- The equipment base is made of aluminum. If the equipment is installed on a metallic substrate that is prone to electrochemical corrosion (such as high-chromium stainless steel, austenitic stainless steel, and nickel-plated steel), insulating gaskets must be fully installed between the equipment and the substrate. (Non-metallic insulating gaskets such as PC, PTFE, or PVDF can be used)

## Tips

To ensure optimal performance of the device, it is suggested that the installation distance between the device and surrounding obstacles be planned with reference to the diagram. If the installation site is well-ventilated, the optimal solution may be deployed based on actual conditions.

### SigenStor EC / Sigen Hybrid (5.0–12.0) TP

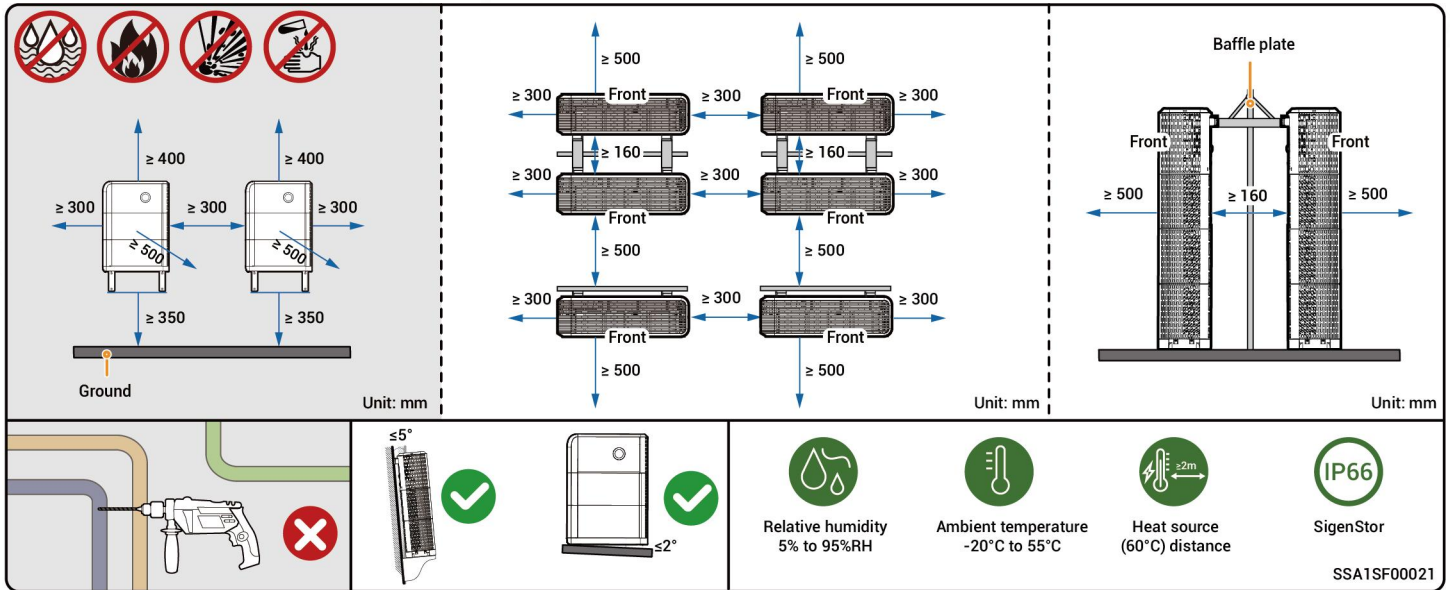

SSA1SF00021



## 4 Installation of inverter and battery pack

### Tips

- Up to six SigenStor BATs are supported for floor installation and up to two for wall installation.
- When installing three or more SigenStor BATs on the floor, use Lift.
- Multiple SigenStor BATs can be installed onsite based on the actual configuration.
- If the floor is prone to stagnant water, please set up a waterproofing platform or install it on the wall.
- The equipment is heavy, do not slip off when handling the equipment to avoid the equipment falling and injuring the operator.
- SigenStor BAT is forbidden to be used after falling, please buy a new one.
- During the installation process, avoid rain, snow, wind, sand, and other foreign objects from entering the device port.
- Do not drag the equipment during installation.

### 4.1 Floor Installation

### Tips

- If the ground is uneven, leveling plates or adjustable feet can be used for leveling, depending on the product received.
- If the installation package the owner receives contains no adjustable feet, only leveling plates can be used for leveling. If both are available, either leveling tool can be used. Please install the equipment according to the actual needs of the owner.
- Please avoid using adjustable feet for leveling in earthquake-prone areas.



Leveling plate



Adjustable feet

SSA10V00034

1

Leveling with leveling plates

Tips

If the bubble level is not centered, use a Leveling plate to adjust.

1

SigenStor BAT	L
≤ 2	$L \geq 35 \text{ mm}$
3–6	$35 \text{ mm} \leq L \leq 65 \text{ mm}$

SSA1IN00156

2

3

105 mm  $\Phi 10 \text{ mm}$

4

5

6

7

M8 9 N·m

SSA1IN00153



- 2** INV1 is the mounting hole on the left side of the inverter for wall installation, while INV2 is the mounting hole on the right side for wall installation.

**Calculation formula for punch height:**

L1 and L2 should be measured from the upper surface of the base:  
 $L1 = N \times 270 \text{ mm} + 261 \text{ mm} \pm 3 \text{ mm}$   
 $L2 = N \times 270 \text{ mm} + 254 \text{ mm} \pm 3 \text{ mm}$

Note: **N** is the number of SigenStor BAT's and **N** ranges from 3 to 6.

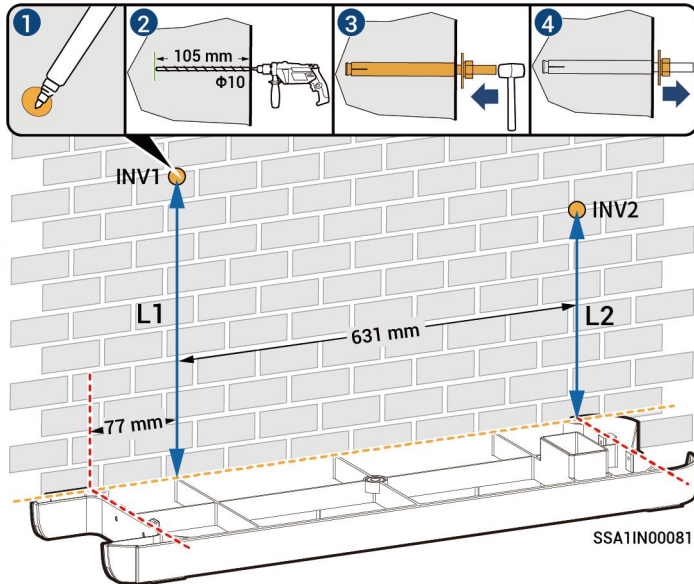

- 3** Before installing the handle, please use a Torque socket wrench to measure the screws and confirm that the screws on Sigen BAT are securely tightened with a torque of 4.5 N·m ( $\pm 0.45 \text{ N·m}$ ).

**Caution**

- Use the new handle supplied with the inverter for your installation operation.
- The "OUT" lettering on the handle must face outwards.
- Do not use a handle with stoppers that fell off or damaged for your installation operation. (Including but not limited to rust, paint peeling, deformation, and fracture)
- The handle is a personal asset of the owner. After use, it must be handed over to the owner for future use and must not be taken away from the installation site.
- The handle shall not be used more than 100 times. The handle that exceeds the use limits shall be scrapped.

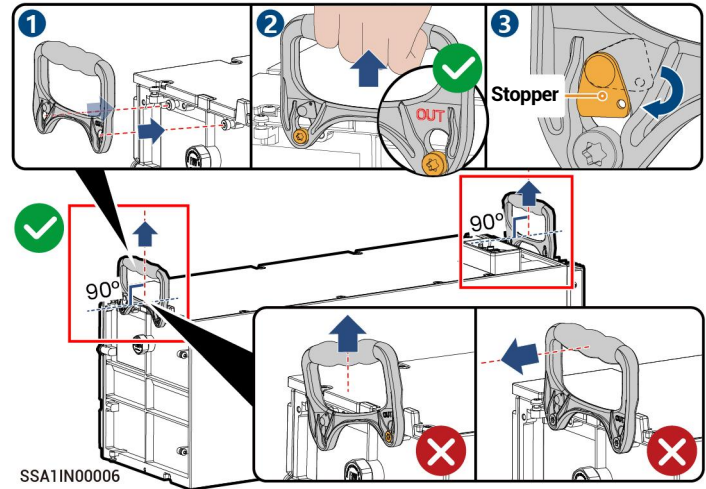

4 SigenStor BAT is kept horizontally and mounted vertically downwards.

SigenStor BAT  $\leq 2$

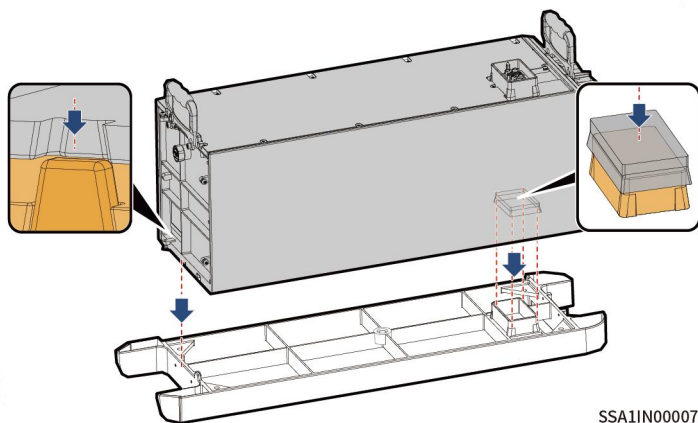

SigenStor BAT  $\geq 3$

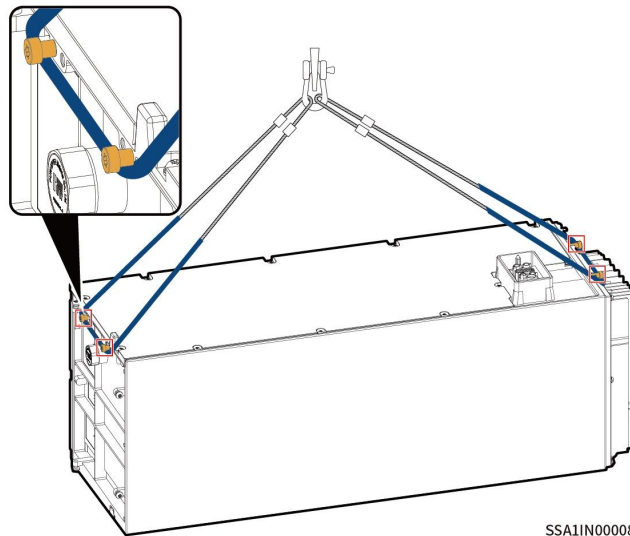

### Tips

During lifting operations, the area where the sling comes in contact with the equipment should be wrapped with a protective layer to avoid damage to the equipment.

## 5 (Optional)

### Tips

- Follow the steps in the figure if the equipment owner received is delivered with plastic plug installed. The chuck screw is contained in the accessory kit.
- Skip this step if the equipment owner receive is delivered with chuck screw installed.

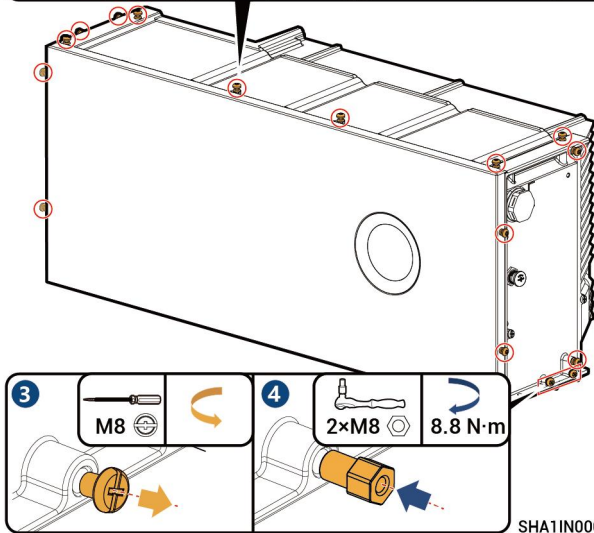
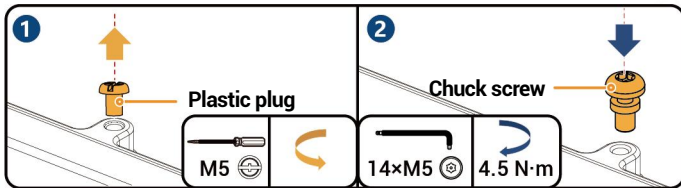

## 6 Arrange SigenStor EC or Sigen Hybrid.

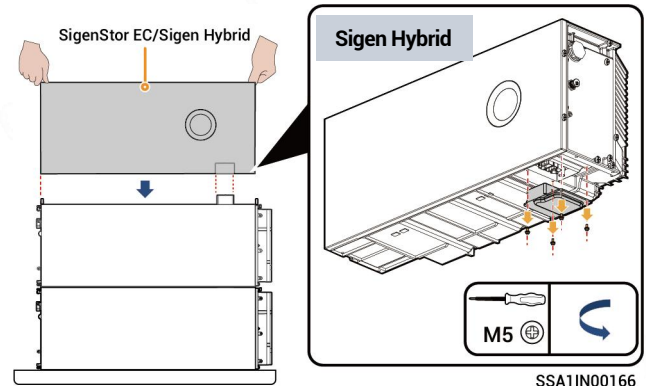

**7** Base bracket has two versions in terms of appearance. The actual product shall prevail. The installation method for both versions remains the same.

Appearance 1

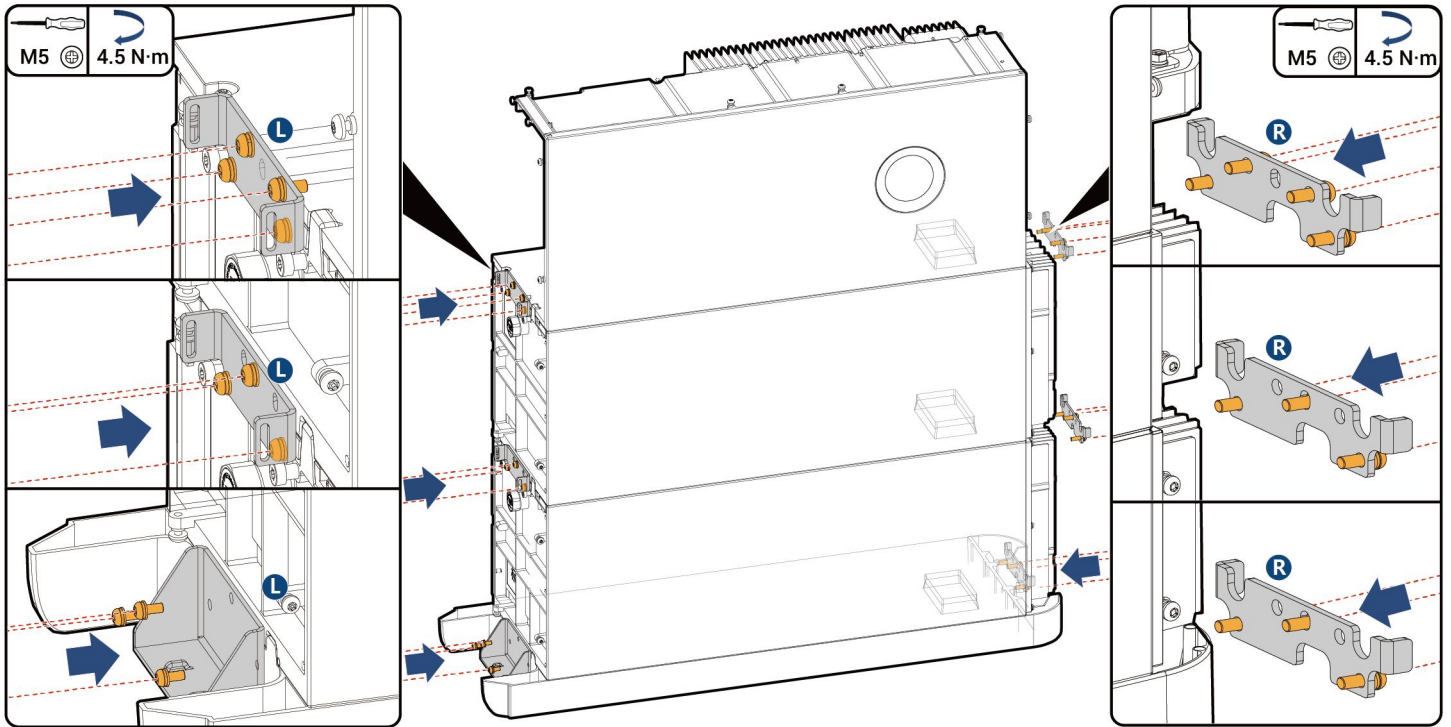

SSA1IN00050

## Appearance 2

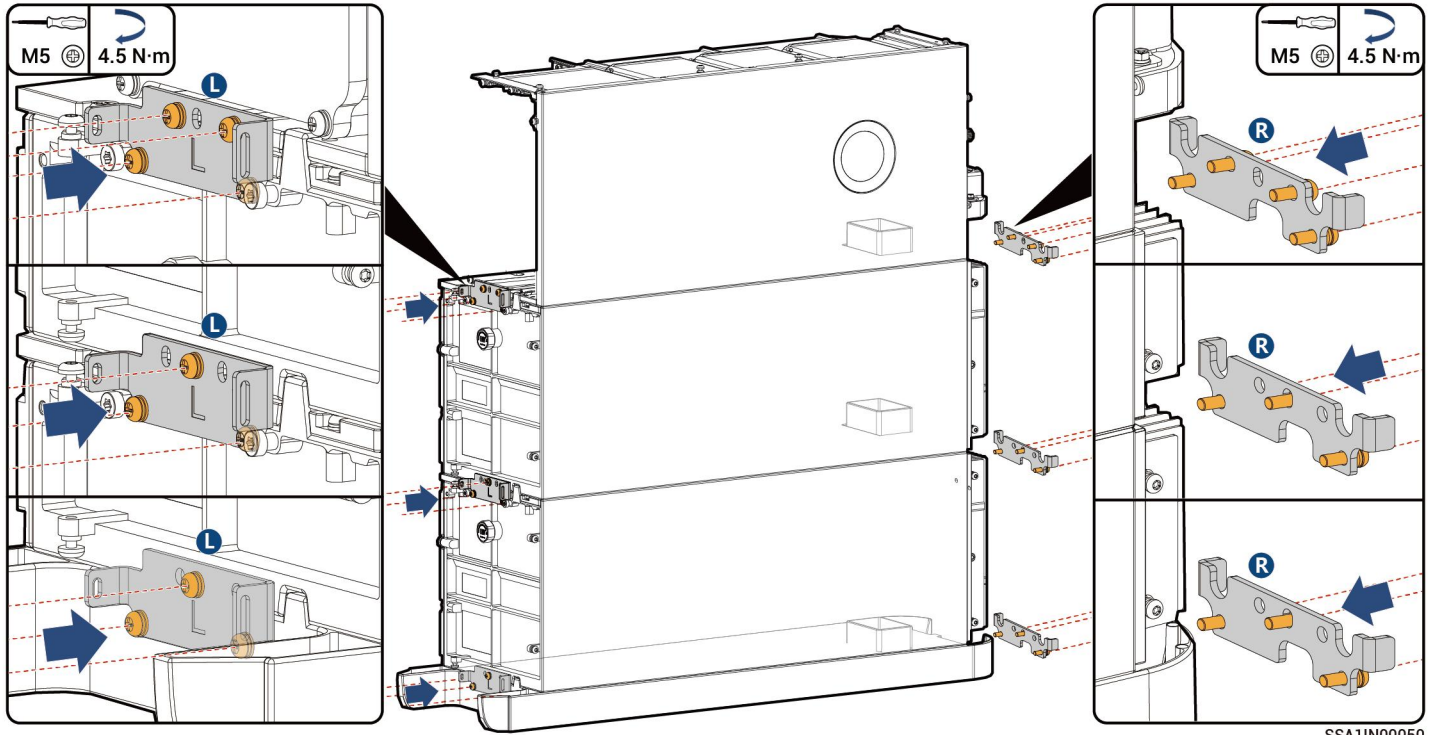

**8** **3** **4** are optional steps. Simply installing the left-side inverter padlock can help prevent theft of the equipment.

SigenStor BAT ≥ 3

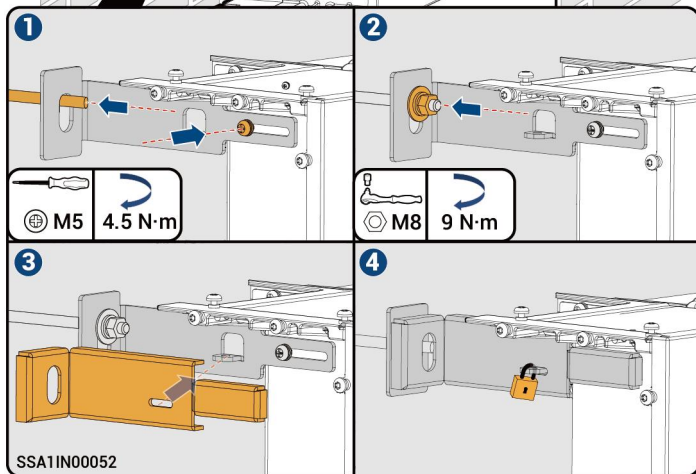
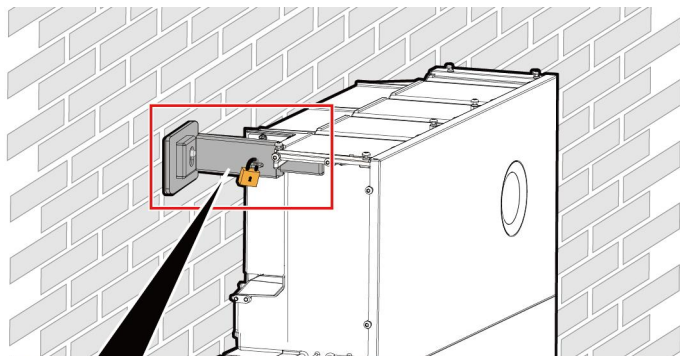

## 4.2 Wall Mounting

**1** There are two installation methods for the Angle Bracket. Please refer to the actual product received for detailed instructions.

### Option 1

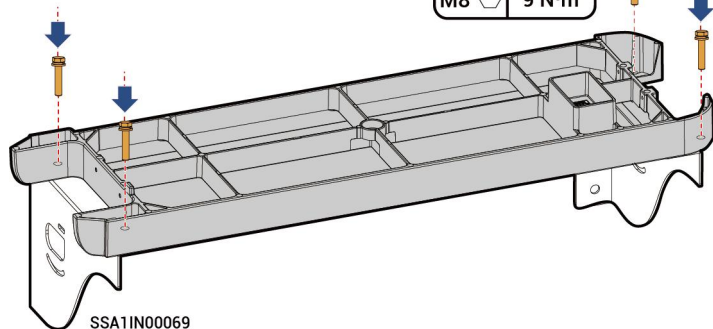
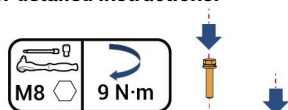

### Option 2

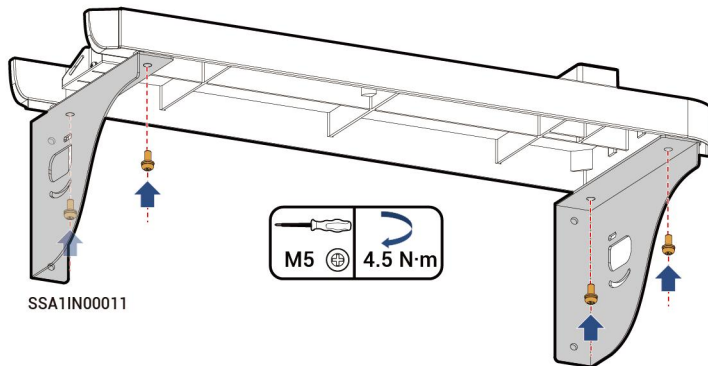
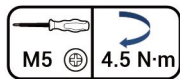

### 2

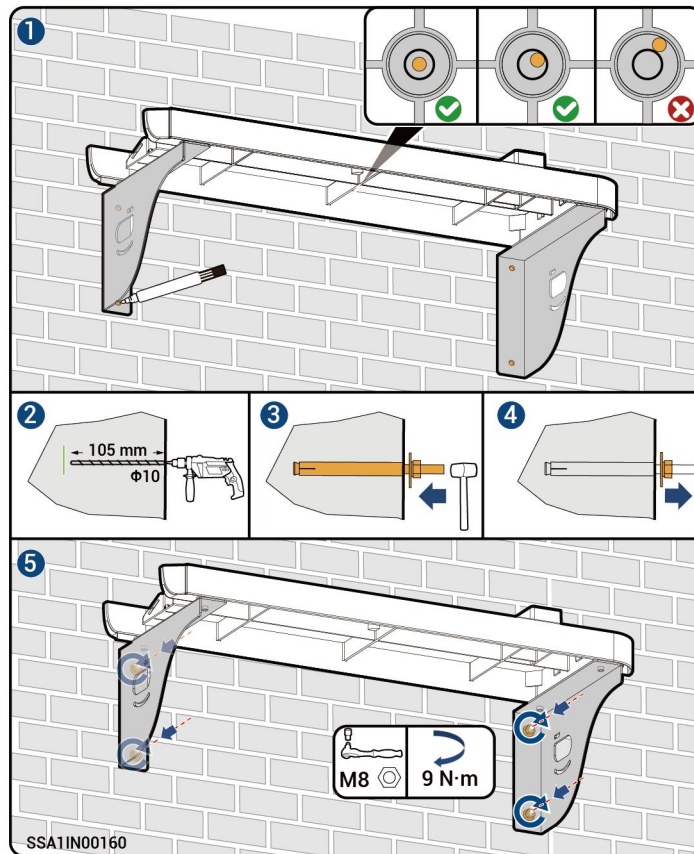

**3****Calculation formula for punch height:**

L1 and L2 should be measured from the upper surface of the base:

$$L1 = N \times 270 \text{ mm} + 261 \text{ mm} \pm 3 \text{ mm}$$

$$L2 = N \times 270 \text{ mm} + 254 \text{ mm} \pm 3 \text{ mm}$$

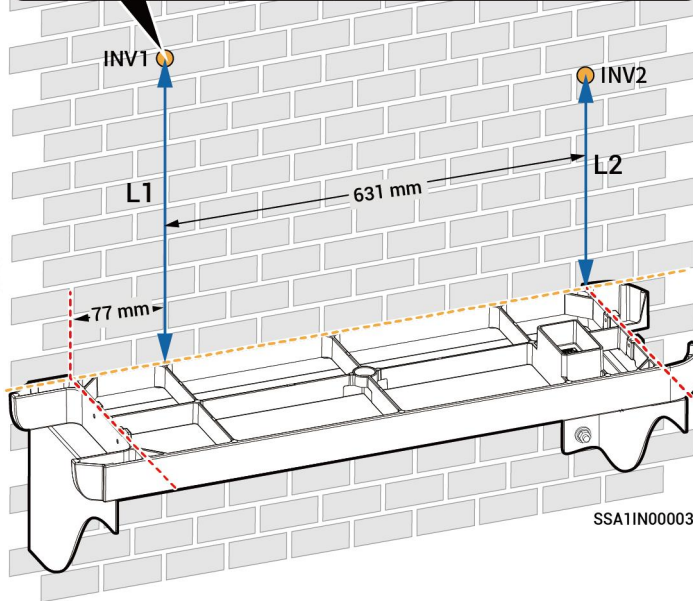
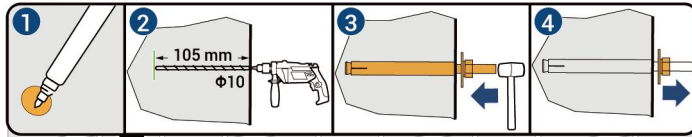
Note: **N** is the number of SigenStor BATs and **N** is 1 or 2.**4** For details about how to place the SigenStor BAT, see Steps **3 4** in Section 4.1 Floor installation.**5** For details about how to place the inverter, see Steps **5 6** in Section 4.1 Floor installation.**6** For the installation of the Base bracket, please refer to Step **7** in Section 4.1 Floor Installation.**7** For the installation of the fasteners for a wall-mounted inverter, please refer to Step **8** in Section 4.1 Floor installation.

## 5 Cable Connection and Component Installation

### Danger

- Before connecting cables, ensure that DC SWITCH is in the OFF state, and the front switch of the AC line is off.
- Do not perform operations on the equipment with power on. Before operation, please make sure all power supplies to the equipment have been disconnected, including but not limited to the grid side, inverter, and diesel generator power switches.
- Do not leave construction residues, for example, cut cores of cables, in or around the equipment, such as, in terminals and in or around fans.

### 5.1 Connection Relationships

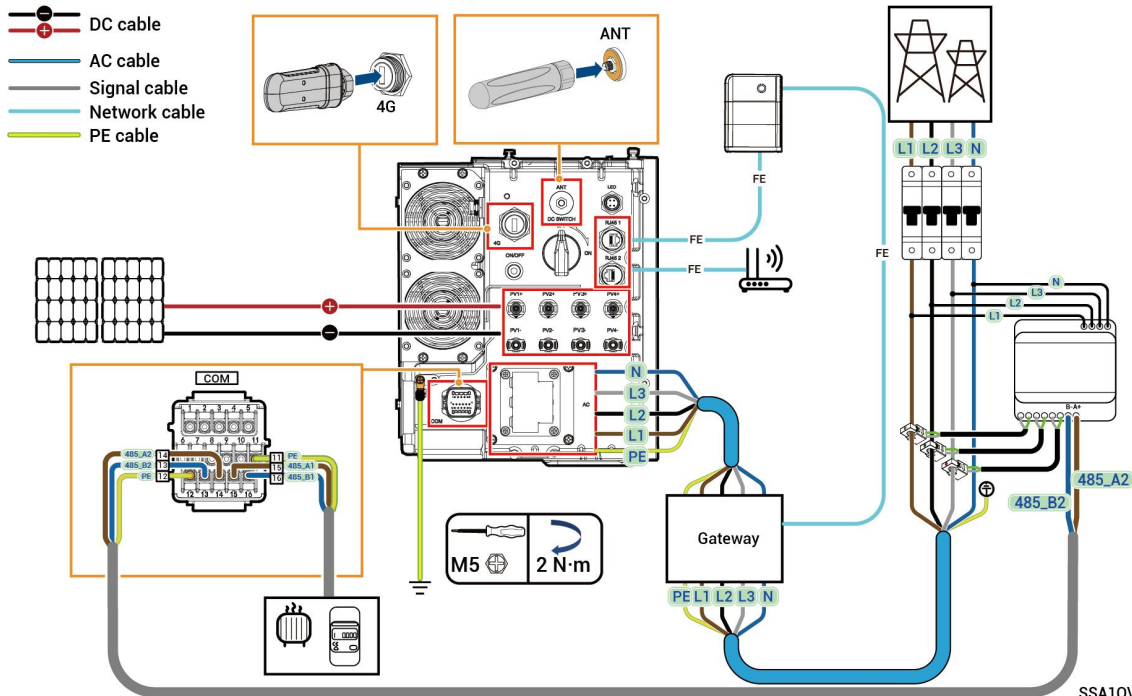

SSA10V00045

## 5.2 Recommended Cabling installation

### Tips

- The cable colors in the figure are used only to distinguish different lines. The cable colors are based on actual conditions.
- Bind the power cable separately from the signal cable.
- There are three routing schemes, Select them based on the actual situation.
- PVC wiring ducts or PVC conduits are recommended to wrap cables outside decorative parts. 60 × 50 mm PVC wiring ducts are recommended and PVC conduits with diameter not less than  $\Phi 80$  are recommended.

Scheme I

- AC cable
- Signal cable
- Protective ground cable
- Network cable
- DC cable

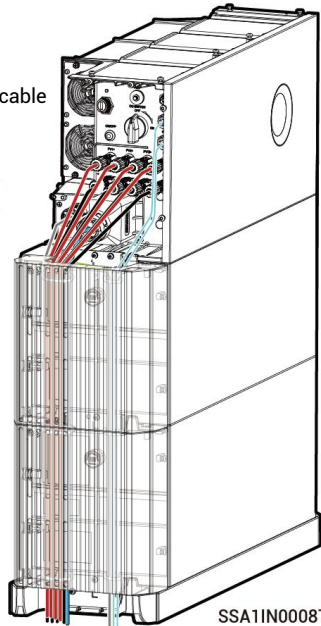

Scheme II

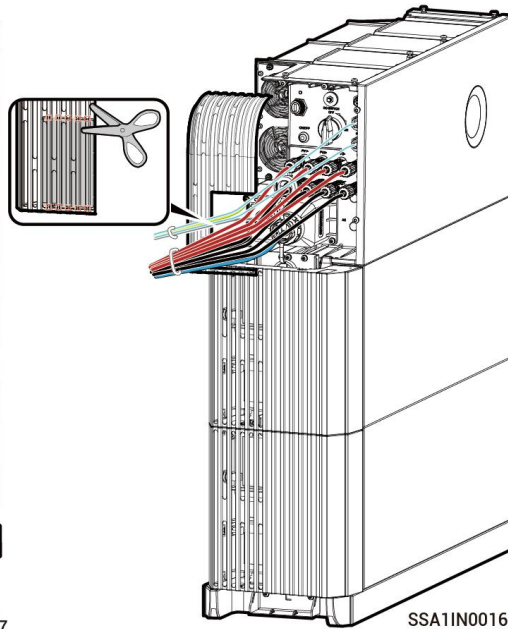

Scheme III

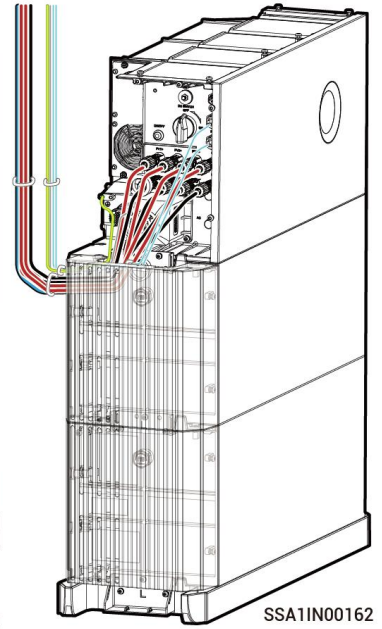

## 5.3 Protective Ground Cable Connection

### Tips

The protective ground wire should be grounded in close proximity.

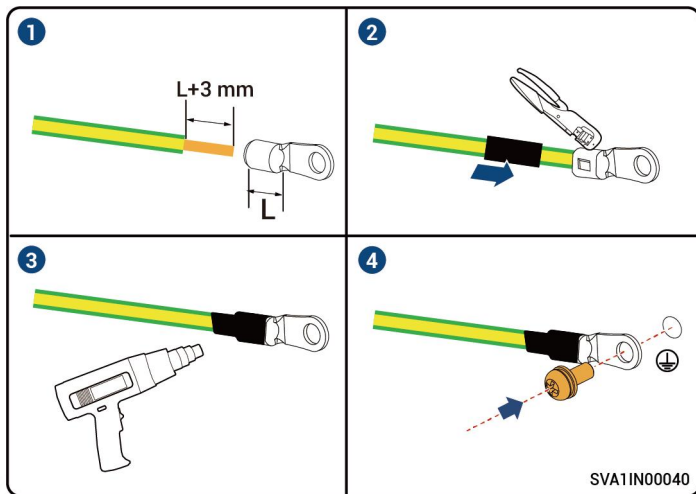

## 5.4 AC Output Cable Connection

### Tips

The AC interface on the inverter is available in four appearances, Please select the appearance as needed.

Appearance 1 (5.0–25.0 kW)

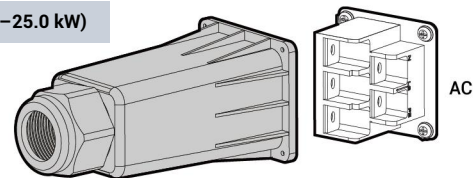

Appearance 2 (5.0–15.0 kW)

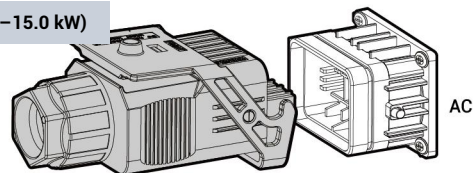

Appearance 3 (17.0–30.0 kW)

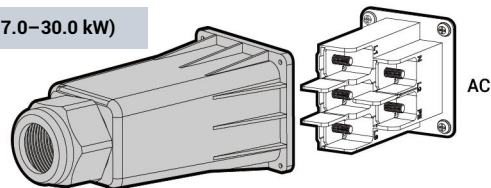

Appearance 4 (17.0–30.0 kW)

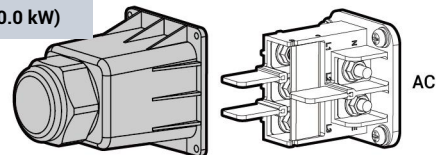

SSA1IN00114

# Appearance 1 (5.0–25.0kW)

1 (Optional) Only 15.0–25.0kW Model requires cold shrink tube.

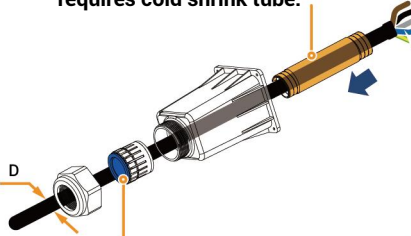

D (mm)	9–13	14–18	19–22	23–26

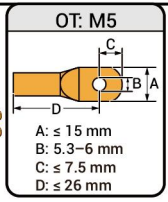
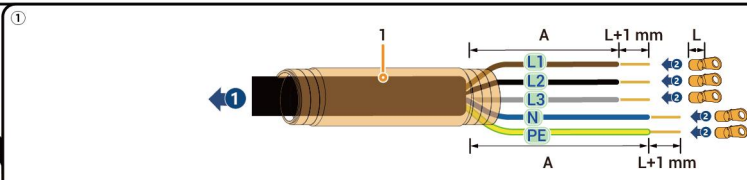

Product power range		L1	L2	L3	N	PE	1
5.0–12.0kW	A (mm)	40–50			55–65		no
15.0–25.0kW		125–135			150–160		have

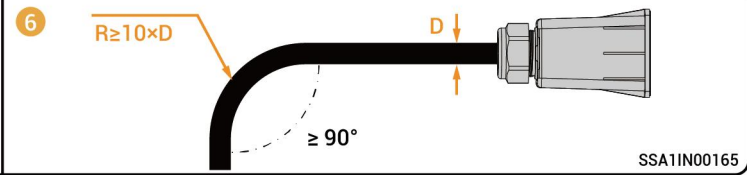
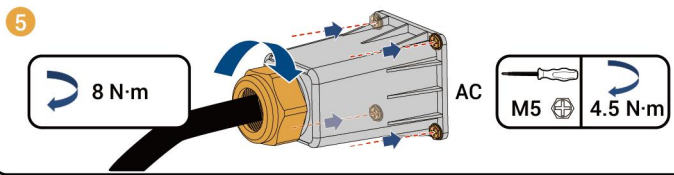
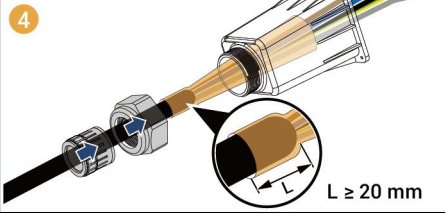
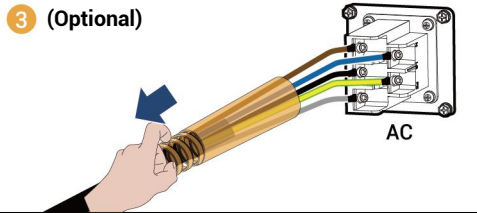
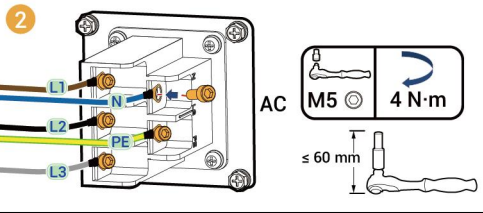
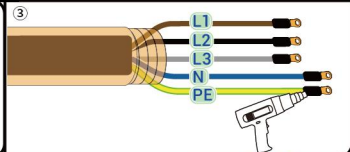
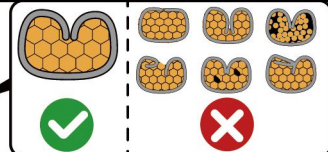
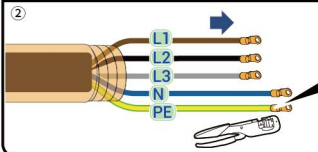

SSA1IN00165

## Appearance 2 (5.0–15.0kW)

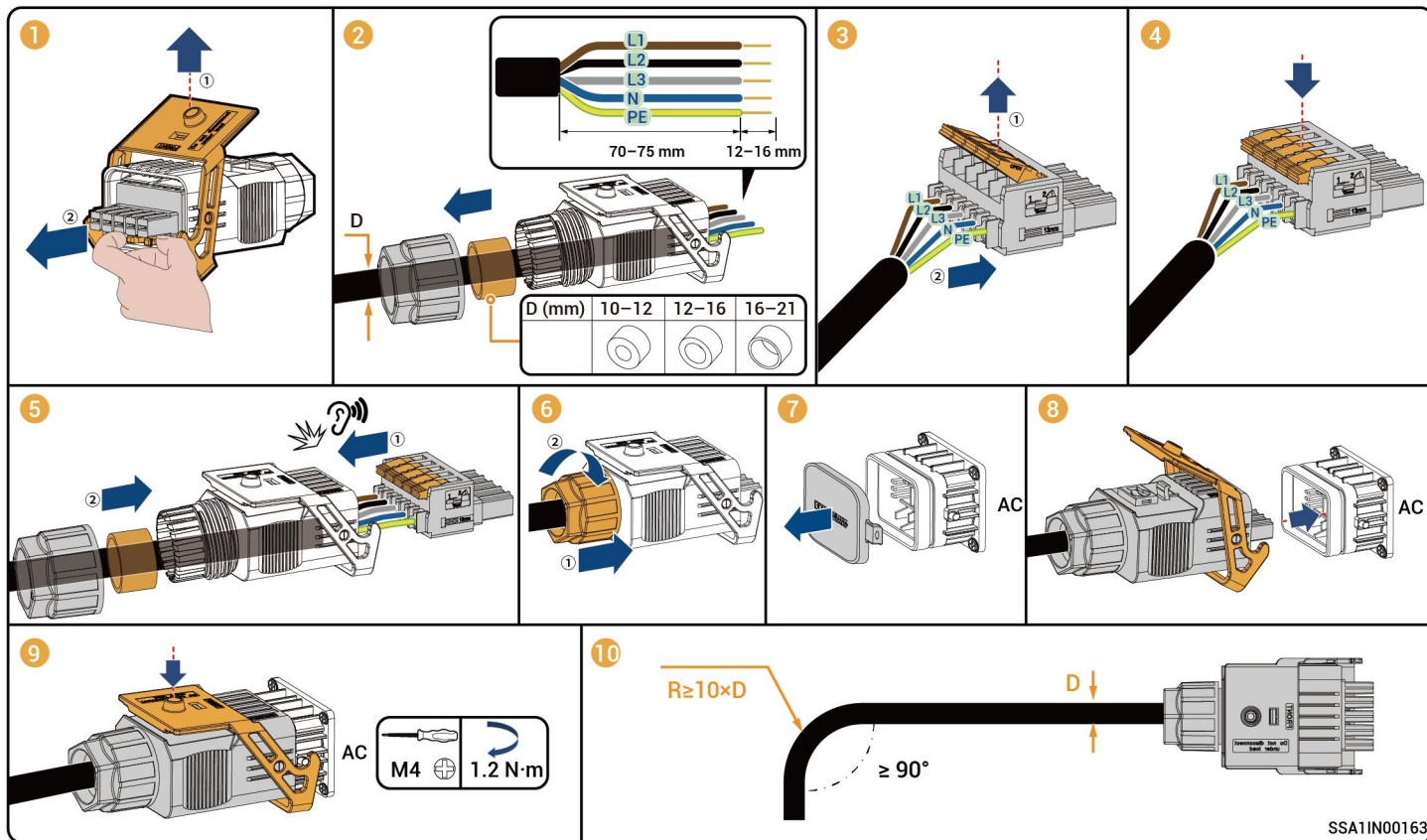

SSA1IN00163

### Appearance 3 (17.0–30.0kW)

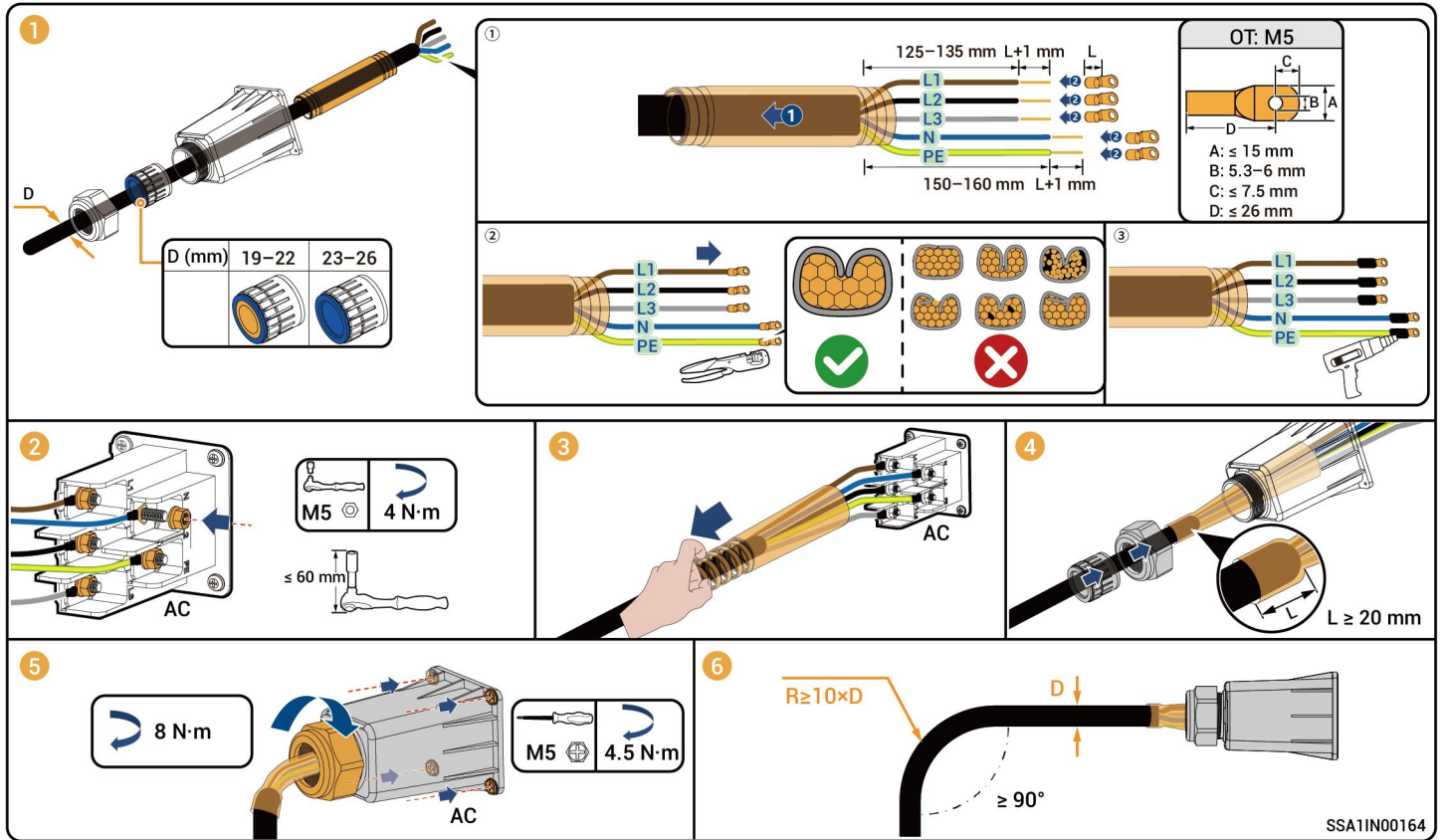

# Appearance 4 (17.0–30.0kW)

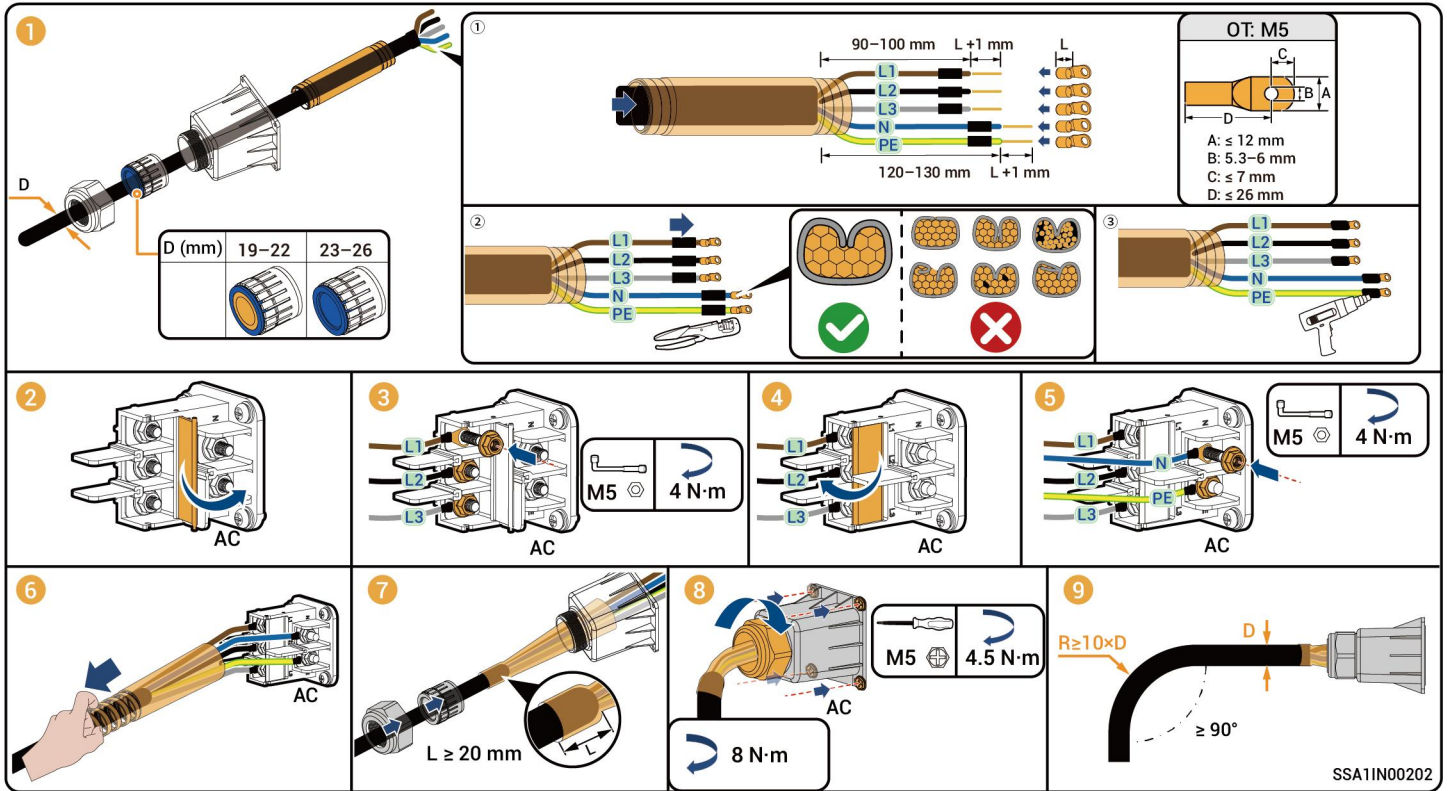

## 5.5 Signal cable Connection

### Tips

- The power sensor needs to be purchased from our company's official channels.
- The appearance and specific wiring of the power sensor can be found in the instruction manual delivered with the case.

### 5.5.1 COM terminal introduction

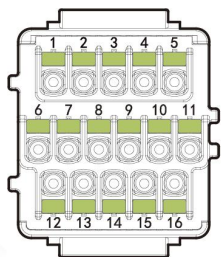

SSA1IN00020

Description	Pin Definition		Pin Number	Sigen Sensor	Sigen Sensor	Sigen Sensor	Sigen Sensor
				TP-DH(SD M630MODB US V2)	TP-CT120-DH (SDM630 MCT 40mA/120A)	TP-CT300-DH(S DM630MCT 40mA/300A)	TP-CT600-DH(SD M630MCT V2/600A)
(Reserved) Supports a maximum signal voltage of 12 V and a signal current of 1 A. Connecting to third-party smart power equipment, such as switch controllers and heat pumps.	DO1-COM	Dry contact 1-Common	1	-	-	-	-
	DO1-NO	Dry contact 1-Normal Open	2	-	-	-	-
	DO2-COM	Dry contact 2-Common	3	-	-	-	-
	DO2-NO	Dry contact 2-Normal Open	4	-	-	-	-
For power scheduling, such as DRM and Ripple Control Receiver(RCR).	DI1	Digital input 1	5	-	-	-	-
	DI2	Digital input 2	6	-	-	-	-
	DI3	Digital input 3	7	-	-	-	-
	DI4	Digital input 4	8	-	-	-	-
-	GND	Signal GND	10	-	-	-	-
Used to connect the rapid shutdown, NS protection device, Emergency power off button(EPO).	DI5	Digital input 5	9	-	-	-	-
RS485-2, Used to access the grid side power sensor.	PE	PE signal shielding ground	12	-	-	-	-
	485_B2	RS485 signal 2_B-	13	B-	13	13	13
	485_A2	RS485 signal 2_A+	14	A+	14	14	14
RS485-1, Used to connect a third-party EMS controller, an electric meter, or a heat pump.	PE	PE signal shielding ground	11	-	-	-	-
	485_A1	RS485 signal 1_A+	15	-	-	-	-
	485_B1	RS485 signal 1_B-	16	-	-	-	-

## 5.5.2 RS485 Signal Cable Connection

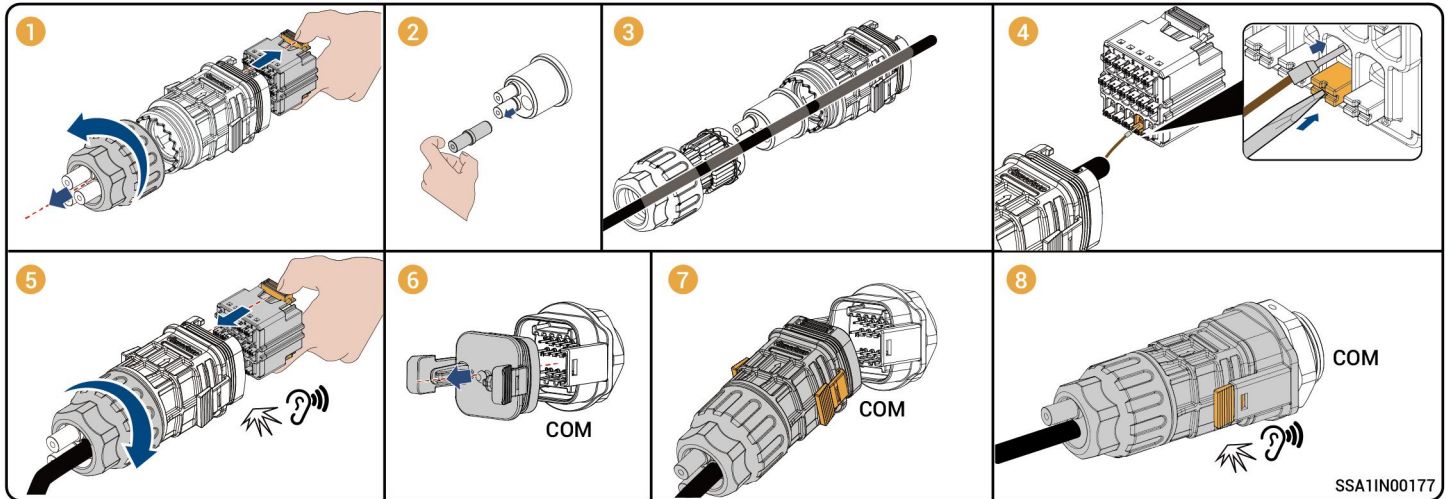
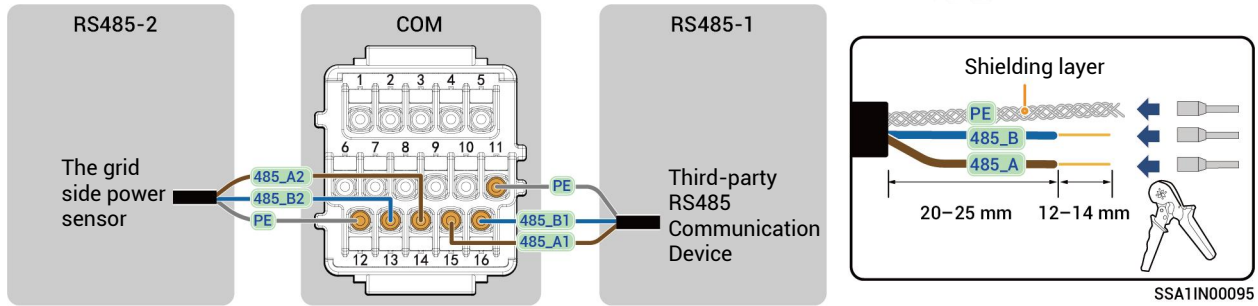

### 5.5.3 (Optional) Grid Scheduling Signal Cable Connection (Take RCR as an example)

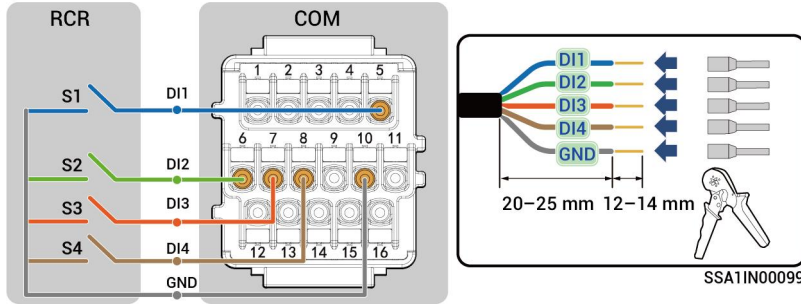

#### Tips

After creating new systems, you can use the mySigen App to set the parameters for Active Dry Contact scheduling or Reactive Dry Contact scheduling. For specific operation steps, please refer to mySigen App Installer Manual.

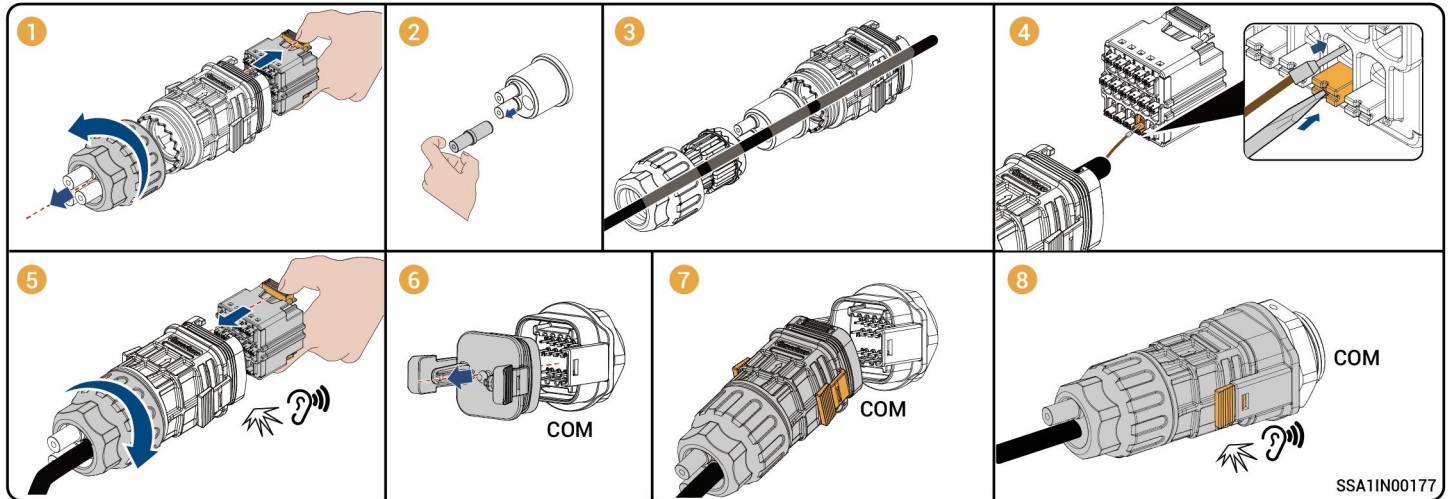

## 5.5.4 NS Protection Signal Cable Connection

### Tips

- If DI1, DI2, DI3, DI4, DI5, and GND are not connected to other devices, an NS protection device can be connected.
- DI1, DI2, DI3, DI4, DI5 and GND use the same method to connect the NS protection device. This section uses DI5 and GND as an example.
- When the NS protection switch is turned on and, the NS protection function is triggered, the inverter automatically shuts down.
- When the NS protection switch is turned off, and the NS protection function is not enabled, the inverter must be manually shut down.
- The rapid shutdown device and the NS protection device use the same DI and GND. Either one of them can be selected.

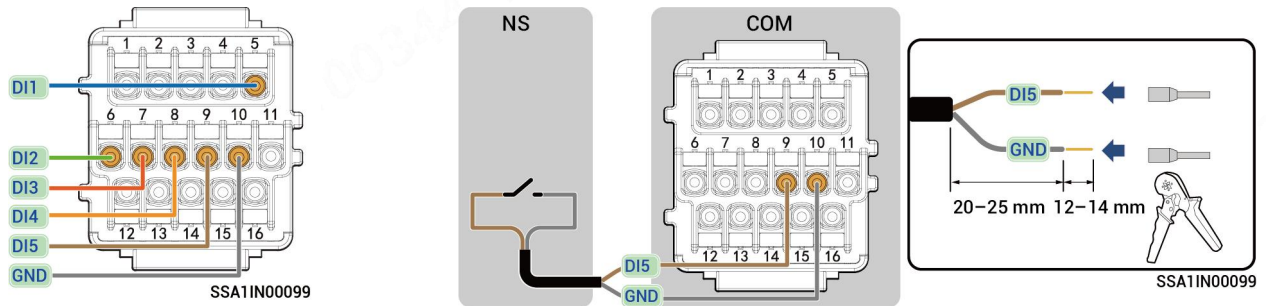

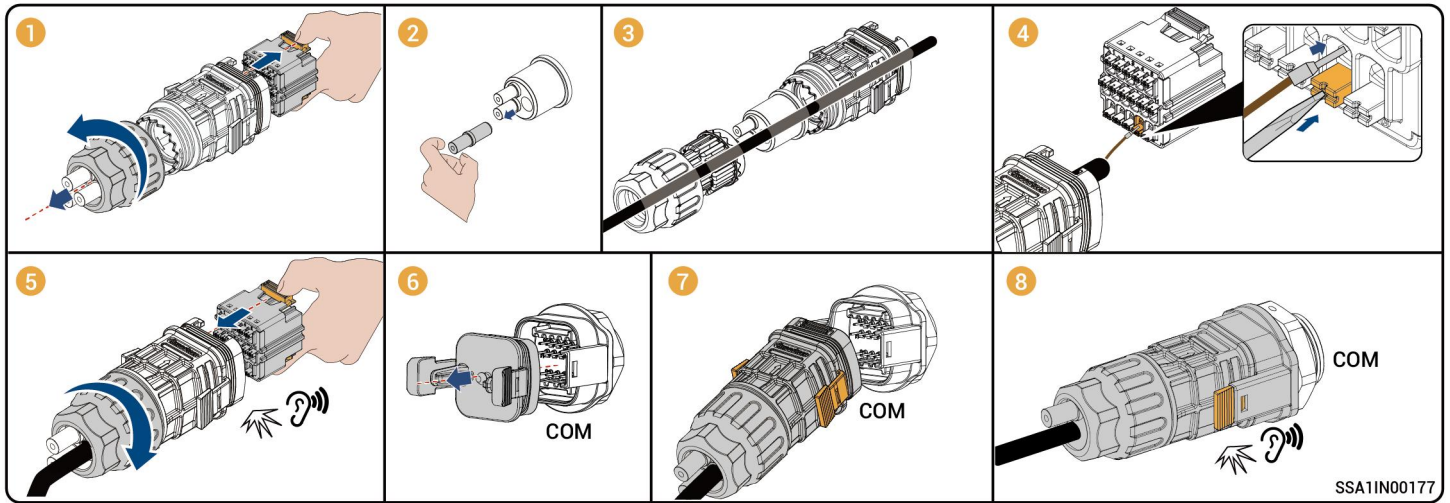

## Tips

After creating new systems, you can use mySigen App to set NS protection parameters. Please refer to mySigen App Installer Manual for detailed instructions.

## 5.5.5 (Optional) Connection of Emergency Power Off (EPO) Button

### Tips

- If DI1, DI2, DI3, DI4, DI5, and GND are not connected to other devices, an emergency power off (EPO) button can be connected.
- The connection method for the emergency power off button to DI1, DI2, DI3, DI4, DI5, and GND is the same. This section uses DI5 and GND as an example.
- To prevent misoperations, the EPO button must have a protective cover, and the connecting cables must be protected with conduits.

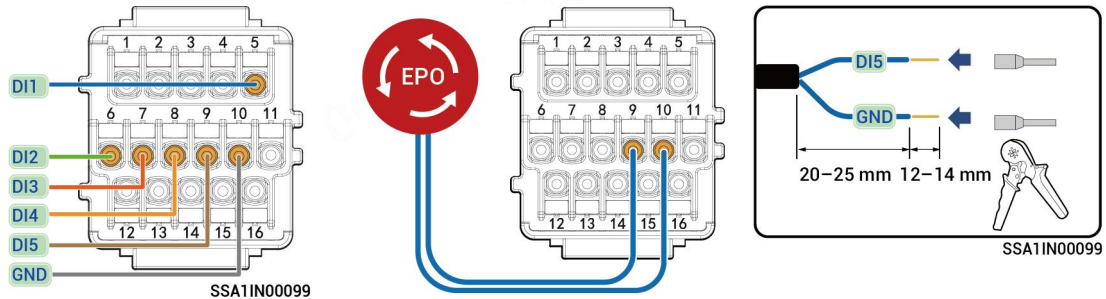

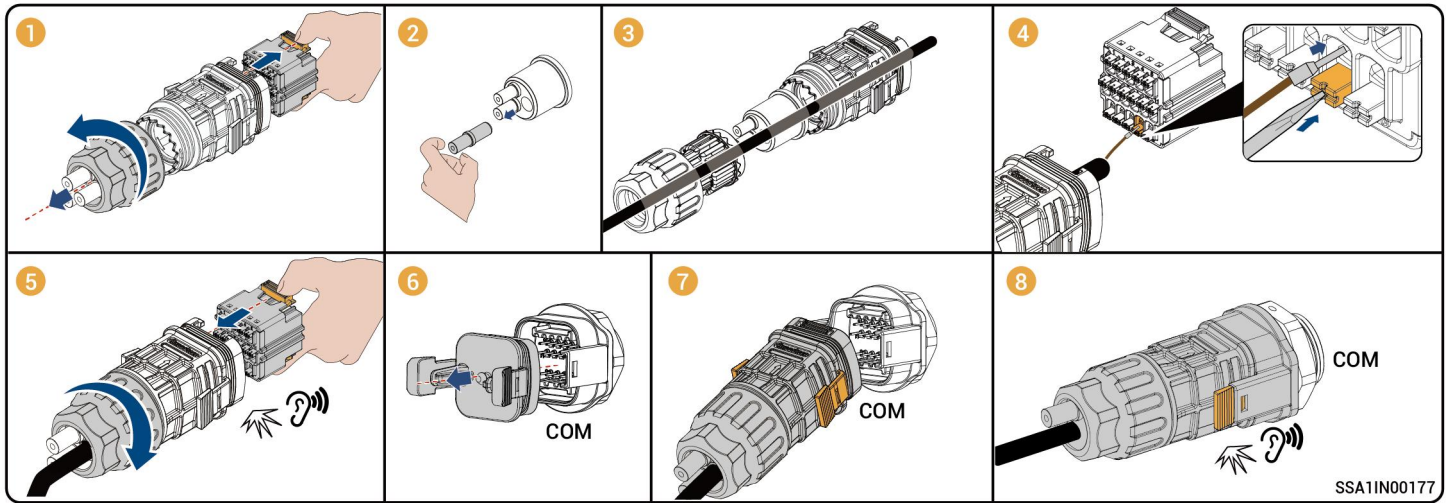

## Tips

After creating new systems, you can use mySigen App to set NS protection parameters. Please refer to mySigen App Installer Manual for detailed instructions.

## 5.6 DC input cable Connection

### Tips

- Please make sure that the circuit breaker on the PV side is electrically neutral before connection.
- Please use the PV terminals supplied with the packing box. The use of terminals from other brands is not allowed, as mixing them poses risks.

### Caution

- If the voltage is negative, the polarity is incorrect. Rectify the fault in time.
- Please select the PV strings according to the table.

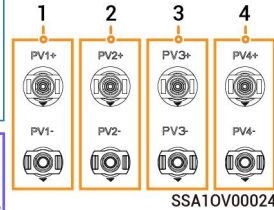

Product power range	PV string formation configuration
5.0–8.0 kW	connected with 2 channels of strings (1, 2)
10.0–15.0 kW	connected with 3 channels of strings (1, 2, 3)
17.0–30.0 kW	connected with 4 channels of strings (1, 2, 3, 4)

**1** Positive metal terminal 8–10 mm

Negative metal terminal

**2** H4TC0003 Amphenol

**3** Positive connector

Negative connector

**4** H4TW0001 Amphenol

**5** Multimeter

**6** PV+ / PV-

**7** PV+ / PV-

SSA11N00169

## 5.7 RJ45 Cable Connection

### Tips

- RJ45 cables are EIA/TIA 568B standard cables and are used for FE communication.
- Two RJ45 Ethernet ports, one is connected to the router, and the other is connected to other equipment.(e.g., inverter, Gateway etc.)

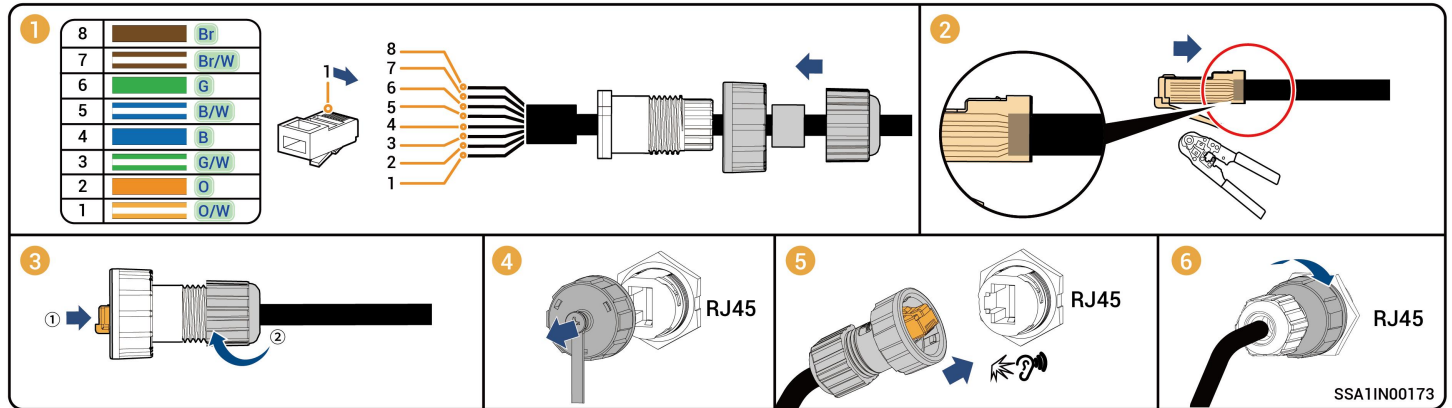

## 5.8 WLAN antenna stick Installation

### Tips

- WLAN communication requires the installation of WLAN antenna stick.
- To ensure good communication, tighten the antenna rod up clockwise. The antenna rod is tightened up when it cannot be easily turned counterclockwise.

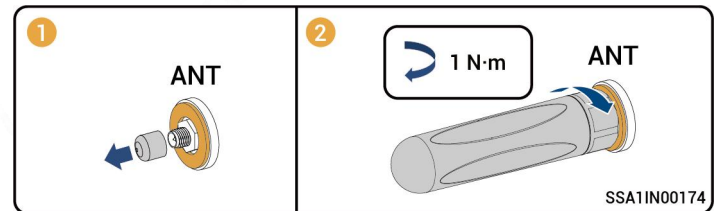

## 5.9 (Optional) Replacing SIM card of Sigen CommMod

### Tips

- When free 4G traffic of CommMod runs out, users must replace an SIM card.
- Please replace the SIM card in Sigen CommMod with a SIM card of your country or region. Recommended data plan:  $\geq 50 \text{ MB/month} \times N$ . (Wherein, N is the number of inverters)
- If you hear only one click sound when assembling Sigen CommMod in Step ③, complete the assembly on the other side.

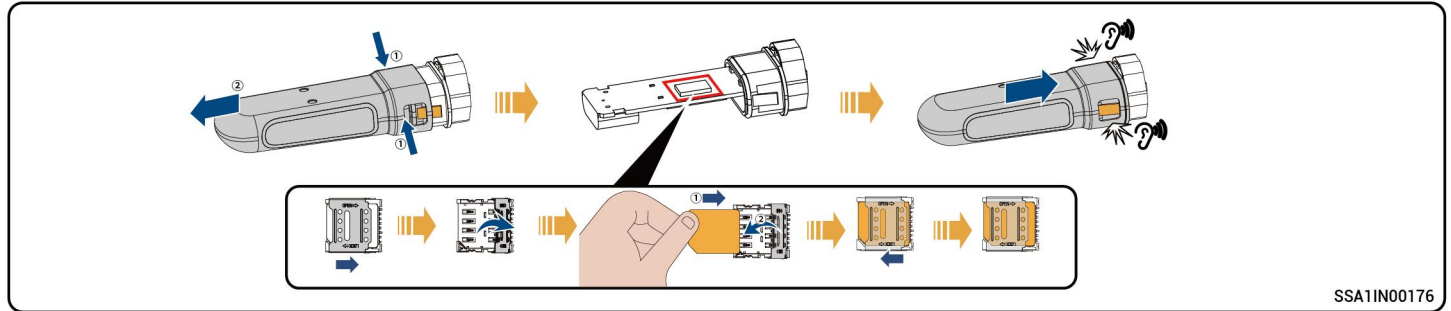

## 5.10 Sigen CommMod Installation

### Tips

Sigen CommMod is required for 4G communication.

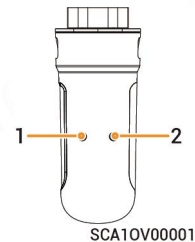
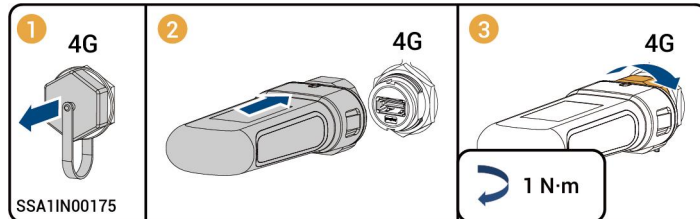

S/N	Indicator	Description
1	Power indicator	-
2	Network state indicator	<ul style="list-style-type: none"> <li>• Slow flashing(200 ms on/1800 ms off): The network is being connected</li> <li>• Slow flashing(1800 ms on/200 ms off): Standby</li> <li>• Quick flashing(125 ms on/125 ms off): Data is being transferred</li> </ul>

## 6 Post-installation Check

S/N	Check Item
1	The equipment has been securely installed.
2	Ground cables, DC cables, signal cables, etc. are installed accurately without leftovers.
3	The cable fastening screws or terminals are properly installed.
4	There are no sharp spikes or acute angles at the cut point of the cable tie.
5	DC SWITCH is in the OFF state.
6	Ports that are not in use have waterproof covers or plugs installed.
7	There is no construction left inside or outside the equipment.

After confirmation, install the SigenStor BAT and SigenStor EC / Sigen Hybrid decorative covers.

## 7 Installation of the Decorative Cover

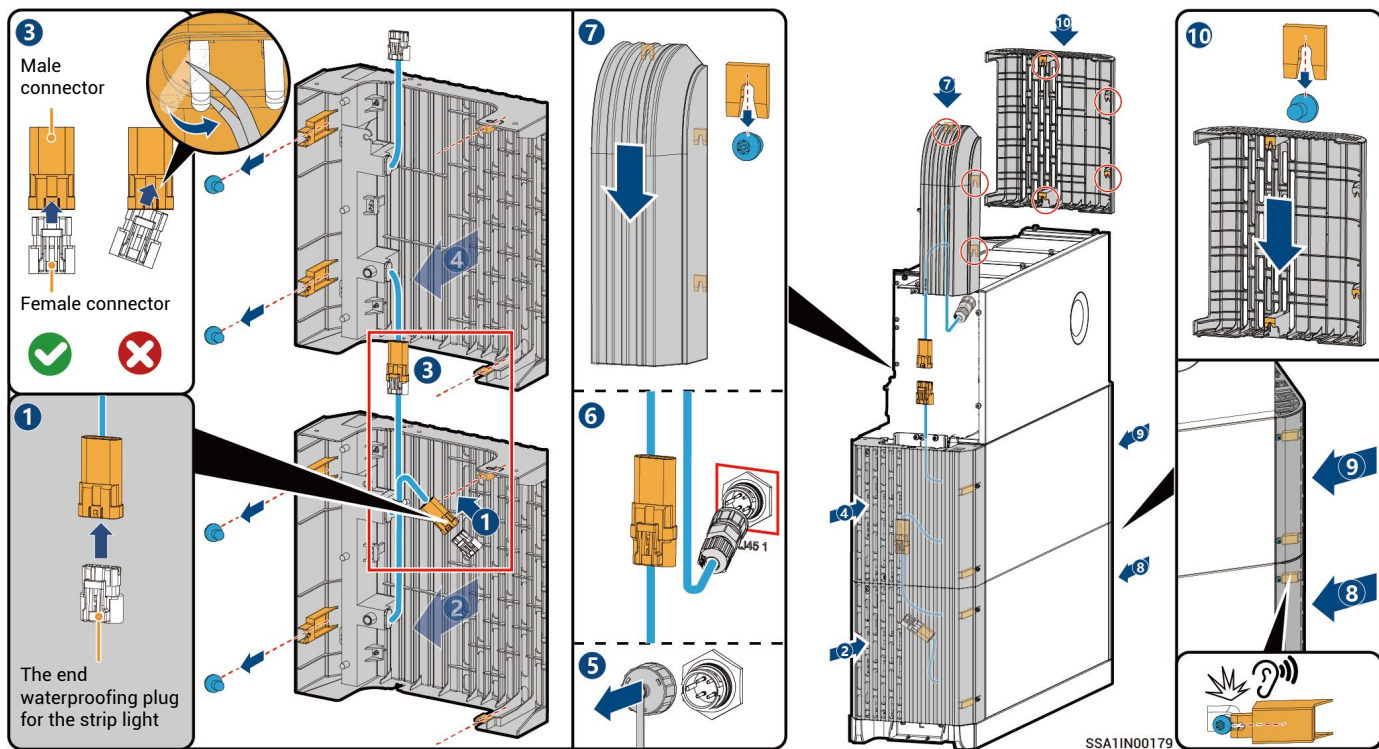

### ⚠ Caution

- The end waterproofing plug for the strip light in step 1 is at the lower end of the decoration on the left side of the inverter, please remove it for spare.
- If the strip light display is abnormal after the device is power-on, please check whether the pin in the male connector is tilted. If it is tilted, please correct it. And then to unplug and re-plug the male and female connectors at the abnormal location, or unplug and re-plug the terminals in the step 6 to resume operation.

## 8 Equipment Power-On

1. Turn on the upstream switch of equipment.
2. Rotate DC SWITCH to ON.
3. Observe the indicators on the front side of the inverter to learn about the equipment status.

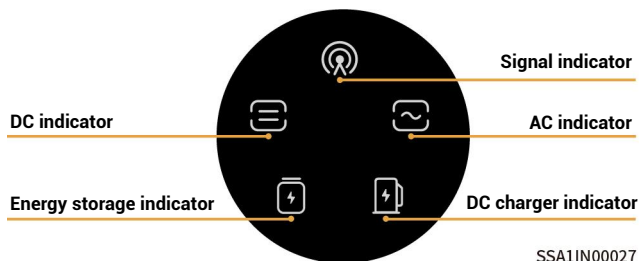

Indicator	Color	State	Description
		Always on	The DC side is connected but not running.
		Always on	The DC side is running.
		-	The DC side is not connected.
		Flash	The DC side is faulty.
		Always on	The inverter is faulty.
		Always on	The AC side is connected but not running.
		Always on	Grid-connected operation.
		Always on	Off-grid operation.
		-	The AC side is not connected.
		Flash	Off-grid overload operation.
		Flash	The AC side is faulty.
		Always on	The inverter is faulty.

Indicator	Color	State	Description
		Always on	All SigenStor BATs are connected but not running.
		Flash	SigenStor BAT is charging.
		Flash	SigenStor BAT is discharging.
		-	All SigenStor BATs lie dormant.
		Flash	Some SigenStor BATs are faulty.
		Always on	All SigenStor BATs are faulty.
		-	The management system is not connected.
		Flash	Connected to local App.
		Always on	Connected to the management system using an FE or WLAN.
		Always on	Connected to the management system over 4G.
		Flash	Insufficient traffic for Sigen CommMod.

## 9 Download and create new system for mySigen APP

- 1 Please enter the "Partner" → "Register Now" at the Company's official website (<https://www.sigenenergy.com>), and complete the account registration based on facts.
- 2 Download the mySigen App and create new system for the device.

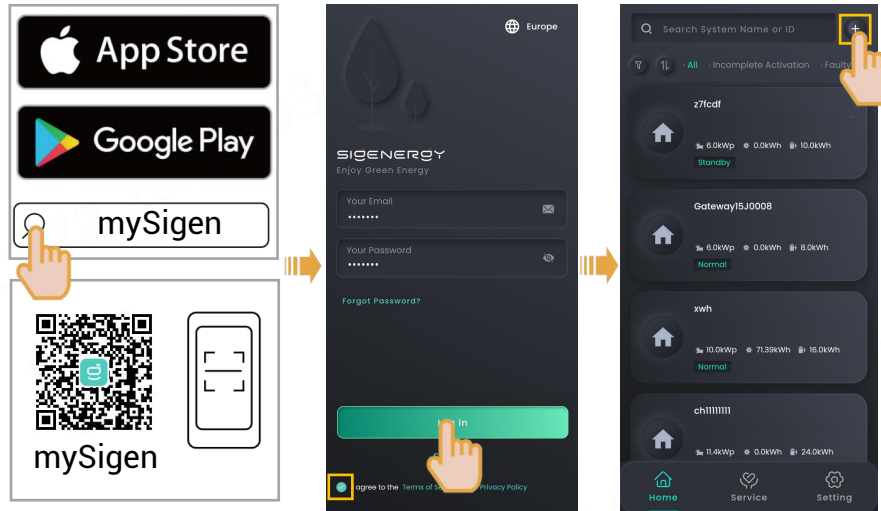

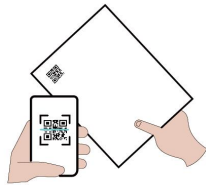
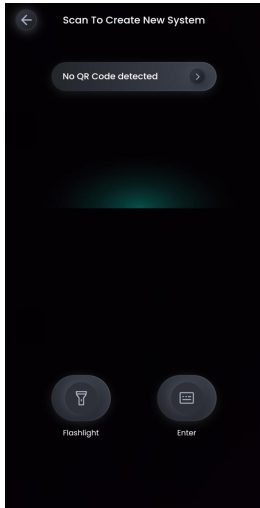

or

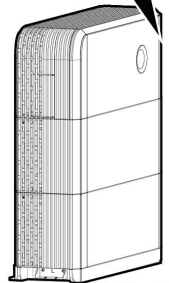

SSA11N00031

➡ According to the interface prompts, complete the startup or refer to the "mySigen App Creating New Systems Guide" to obtain the operation method of startup.



**Scan the SN code label on the accompanying box material. If the SN is lost, scan the SN on the side of the inverter.**

**3** Upon completion of the new system creation, the installer shall inform the owner to check its "sigencloud" e-mail within 24 hours and proceed with activating its account.

**4** After powering on the equipment, install the remaining decorative covers.

## Tips

If the installation fails even when you strictly follow the installation instructions, properly adjust the tightness of the chuck screw, as shown in the figure.

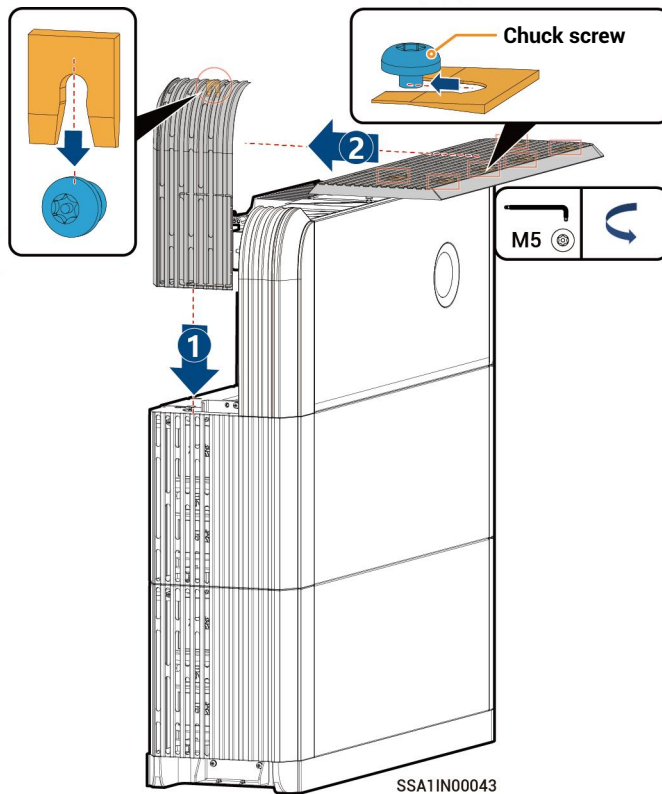

**Sigenergy Technology Co., Ltd.**



Website	LinkedIn	YouTube
---------	----------	---------

**www.sigenergy.com**



**Copyright © Sigenergy Technology Co., Ltd. 2026. All rights reserved.**

Description in this document may contain predictive statements regarding financial and operating results, product portfolio, new technology, configurations and features of product. Several factors could cause difference between actual results and those expressed or implied in the predictive statements. Therefore, description in this document is provided for reference purpose only and constitutes neither an offer nor an acceptance. Sigenergy Technology Co., Ltd. may change the information at any time without notice.