

# Delta-grid Meter Selection Guide

---

Delta grid is a special three-phase power configuration, ideal for high-reliability applications. Installing the energy meter properly demands attention to wiring methods and special configurations. Designed for engineers and procurement specialists, this whitepaper provides a concise guide to selecting the optimal meter for delta-grid systems. We outline key models, connection techniques, and configurations to ensure accurate measurement and reliable performance.

**TECHNICAL  
WHITE PAPER**

**Delta-grid Meter Selection Guide**

[Download Now](#)



To ensure proper system compatibility and communication, *you must purchase the designated meter from Growatt*. Meters purchased through other channels may not function correctly with our inverters, and Growatt will not be liable for any resulting system failures or performance issues.

The communication address, baud rate, and current ratio are pre-configured prior to shipment. However, we still recommend verifying these parameters according to this guideline.

### 1. TPM-CT-D (DSSU666) from Growatt

As an intelligent instrument combining measurement and communication function, DSSU666 series 3P3W electronic energy meter (din-rail) is mainly applied into the measurement and display for the electric parameters including 2-phase voltage, 2-phase current, active power, reactive power, frequency, imported energy, exported energy, 3-quadrant energy, etc. Adopting the standard DIN35mm din rail mounting and modular design, it is characterized with small volume, easy installation and easy networking.

Key Parameters	
Rated voltage	3X400V
Reference frequency	50Hz/60Hz
Input current	1.5(6)A
Rated temperature	-10°C~+45°C
Communication	RS485 output for Modbus RTU
Baud rate	9600
Pulse	6400imp/kWh
Sealing	IP51 (indoor)

The meter issued by Growatt do not come with CTs, and the customer needs to purchase CTs separately. Since the input current of the meter ranges from 1.5 to 6A, so the CTs must be with ratios of X/5A (X=100, 150, 200, 250...) to ensure that the current on the secondary side does not exceed 6A. The X value (current on the primary side) is mainly determined by the greater of the PV's maximum power generation and the load's maximum power consumption, customers can choose according to their situations.

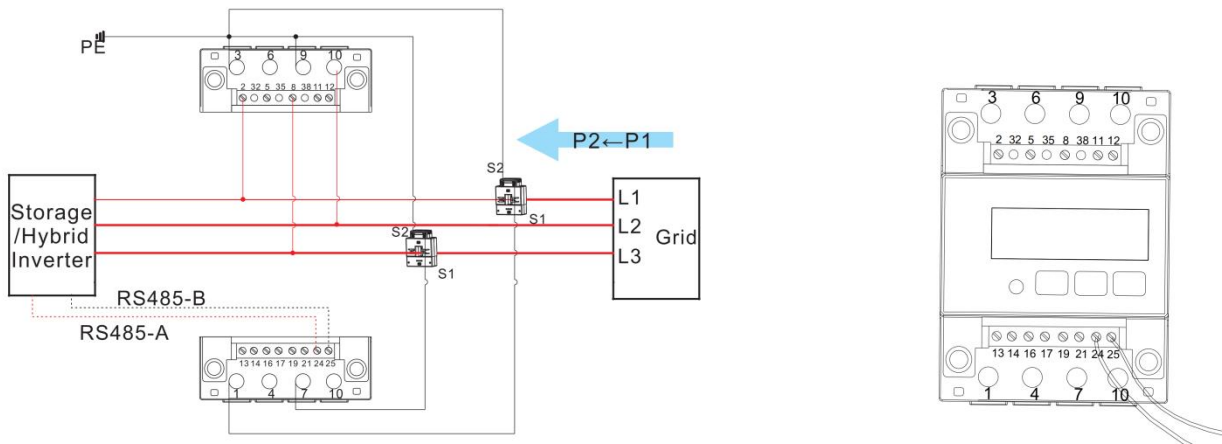

Pin	2	5	8	10	24	25
Meaning	UA	UB	UC	UN	RS485 A	RS485 B

Pin 2/5/8: Phase A/B/C voltage input terminal

Pin 10: Phase N voltage input terminal. *Here we take L2 as virtual neutral line.*

Pin 24/25: RS485 terminal A/B

Pin	1	3	4	6	7	9
Meaning	IA*	IA	IB*	IB	IC*	IC

Pin 1/4/7: Phase A/B/C current input terminal

Pin 3/6/9: Phase A/B/C current output terminal

When connecting the smart meter to the inverter, connect one end of the cable to terminal 24 (485A) and terminal 25 (485B) of the smart meter and the other end to 485A and 485B of the inverter COM port. In most cases, the red cable is used for 485A and the black cable for 485B. The communication address of the meter is 04 by default, the baud rate is 9600. If the meter fails to communicate with the inverter, you can check the parameter settings by following the instructions (The password is 701 by default).

SET button: Represents “confirmation” or “cursor shift” (when entering digits)

ESC button: Represents “exit”

“→” (^) button: Represents “add”



## 2. TPM-CT-E (SDM630MCT-MA) from Growatt

SDM630MCT-MA is a multi-function rail meter, it can accurately measure and display various parameters in 1P2W/3P3W/3P4W: voltage, current, active power, reactive power, frequency, imported energy, exported energy, total harmonics, etc. The meter is connected with external CTs and suitable for various high and low voltage power grids. Its RS485 communication port with Modbus RTU protocol supports remote monitoring and control.

Key Parameters	
Rated voltage	3X230/400V
Reference frequency	50Hz/60Hz
Input current	<40mA
Rated temperature	-25°C~+55°C
Communication	RS485 output for Modbus RTU
Baud rate	9600
Pulse	3200imp/kWh
Sealing	IP51 (indoor)

The meter issued by Growatt comes with CTs, users can choose the CT specification for 100A/40mA or 250A/40mA according to the greater of the PV's maximum power generation and the load's maximum power consumption when placing an order.

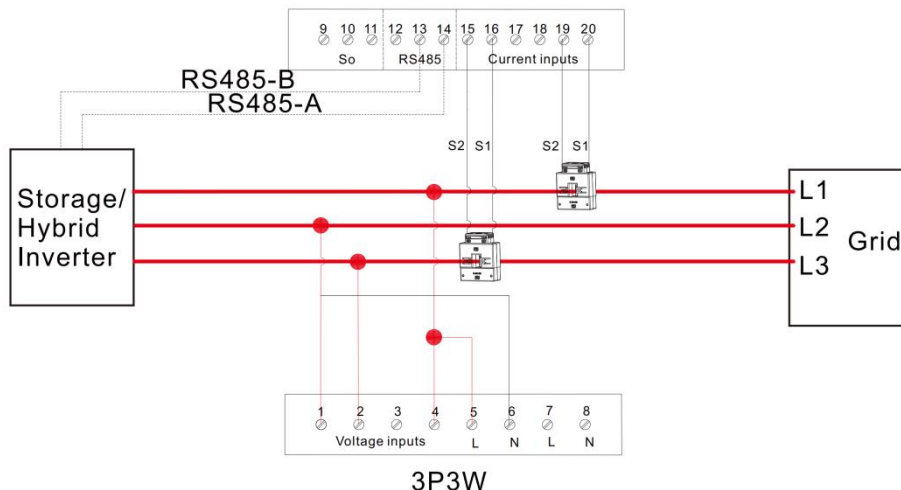

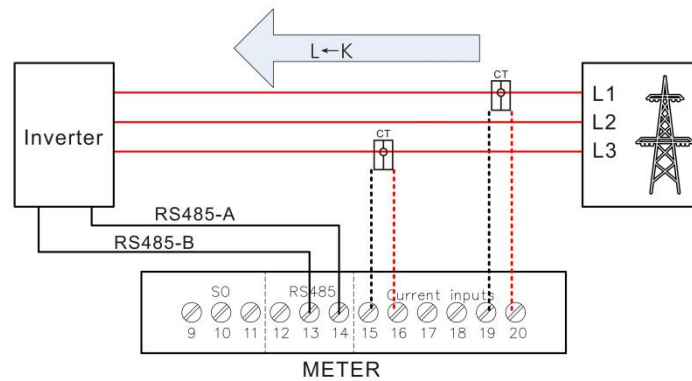

Pin	4	3	2	1	14	13
Meaning	UA	UB	UC	UN	RS485 A	RS485 B
Pin	5	6				
Meaning	UA	UN				

Pin 4/3/2: Phase A/B/C voltage input terminal

Pin 1: Phase N voltage input terminal. *Here we take L2 as virtual neutral line.*

Pin 14/13: RS485 terminal A/B

Pin 5/6: Ancillary sources

Pin	20	19	18	17	16	15
Meaning	IA*	IA	IB*	IB	IC*	IC

Pin 20/18/16: Phase A/B/C current input terminal

Pin 19/17/15: Phase A/B/C current output terminal

When connecting the smart meter to the inverter, connect one end of the cable to terminal 14 (485A) and terminal 13 (485B) of the smart meter and the other end to 485A and 485B of the inverter COM port. In most cases, the red cable is used for 485A and the black cable for 485B.

The communication address of the meter is 02 by default, the baud rate is 9600. If the meter fails to communicate with the inverter, you can check the parameter settings by following the instructions (The password is 1000 by default).

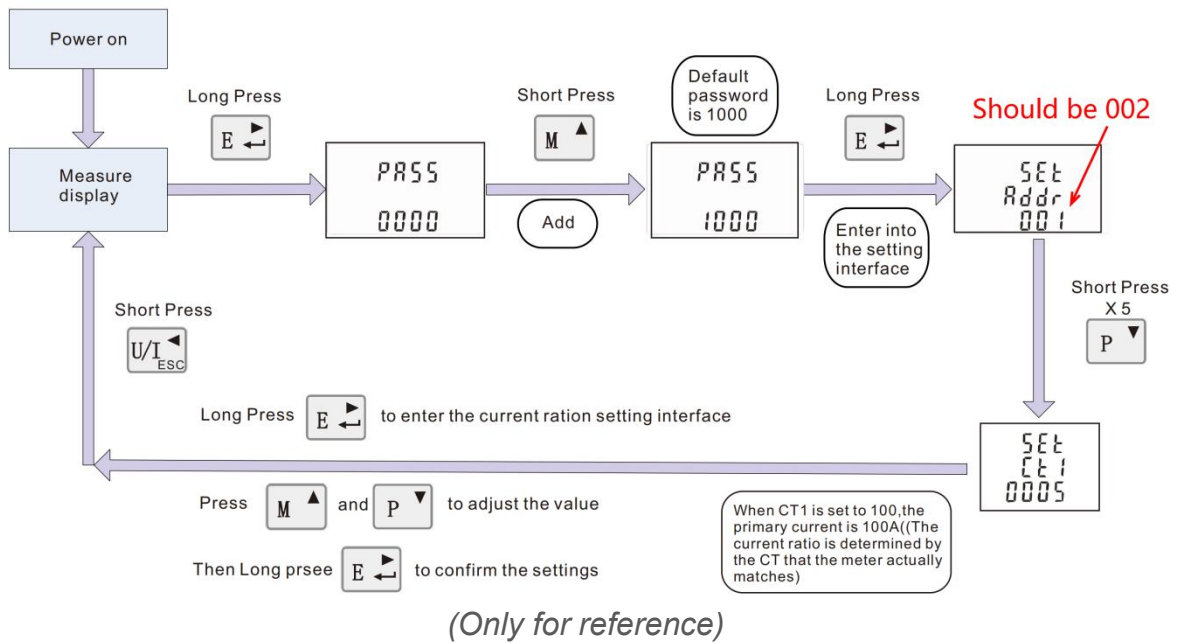

 Short press: display electric energy, →; Long press: Enter

 Short press: display power factor and frequency, ↑; Long press: Alt

 Short press: display power, ↓; Long press: Shift



 Short press: display voltage and current, ←; Long press: ESC

This meter has two sizes of CT, one is 100/40mA and the other is 250/40mA. The rated current of the secondary circuit is defaulted to 40mA, i.e. CT2=40mA in the meter settings. The rated current of the primary circuit is according to the actual CT specification purchased, i.e. CT1=100 or 250.





To use this meter for the delta grid, users also need to set the grid to 3P3W as follows:



From the set-up menu, use  and  buttons to select the system option. The screen will show the currently selected power supply.



Press  to enter the selection routine. The current selection will flash.

Use  and  buttons to select the required system option: 3P3W. Finally press  to confirm the selection.

### 3. TPM-CT-E-EU (SDM630MCT V2) from Growatt

SDM630MCT V2 is a multi-function rail meter, it can accurately measure and display various parameters in 1P2W/3P3W/3P4W: voltage, current, active power, reactive power, frequency, imported energy, exported energy, total harmonics, etc. The meter is connected with external CTs and suitable for various high and low voltage power grids. Its RS485 communication port with Modbus RTU protocol supports remote monitoring and control.

Key Parameters	
Rated voltage	3X230/400V
Reference frequency	50Hz/60Hz
Input current	<5A
Rated temperature	-25°C~+55°C
Communication	RS485 output for Modbus RTU
Baud rate	9600
Pulse	3200imp/kWh
Sealing	IP51 (indoor)

The meter issued by Growatt comes with CTs, users can choose the CT specification for 250/5A, 600/5A or 1200/5A according to the greater of the PV's maximum power generation and the load's maximum power consumption when placing an order.

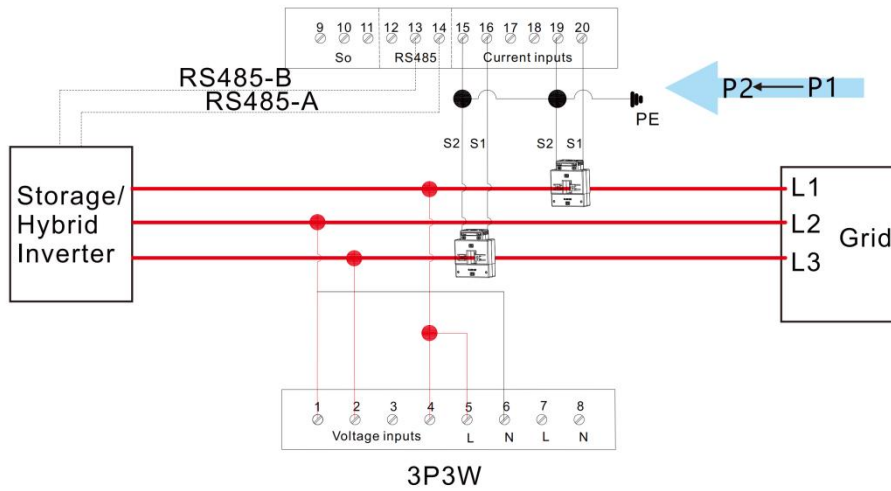

Pin	4	3	2	1	14	13
Meaning	UA	UB	UC	UN	RS485 A	RS485 B
Pin	5	6				
Meaning	UA	UN				

Pin 4/3/2: Phase A/B/C voltage input terminal

Pin 1: Phase N voltage input terminal. *Here we take L2 as virtual neutral line.*

Pin 14/13: RS485 terminal A/B

Pin 5/6: Ancillary sources

Pin	20	19	18	17	16	15
Meaning	IA*	IA	IB*	IB	IC*	IC

Pin 20/18/16: Phase A/B/C current input terminal

Pin 19/17/15: Phase A/B/C current output terminal

When connecting the smart meter to the inverter, connect one end of the cable to terminal 14 (485A) and terminal 13 (485B) of the smart meter and the other end to 485A and 485B of the inverter COM port. In most cases, the red cable is used for 485A and the black cable for 485B.

The communication address of the meter is 02 by default, the baud rate is 9600. If the meter fails to communicate with the inverter, you can check the parameter settings by following the instructions (The password is 1000 by default).

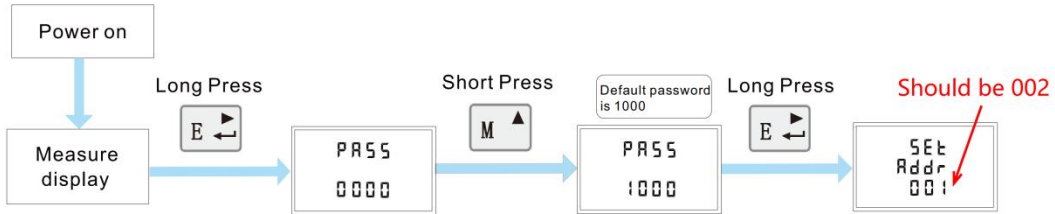

 Short press: display electric energy, →; Long press: Enter

 Short press: display power factor and frequency, ↑; Long press: Alt

 Short press: display power, ↓; Long press: Shift



 Short press: display voltage and current, ←; Long press: ESC

This meter has three sizes of CT, 250/5A, 600/5A and 1200/5A. The rated current of the secondary circuit should be 5A, i.e. CT2=5A in the meter settings. The rated current of the primary circuit is according to the actual CT specification purchased, i.e. CT Rate=50, 120 or 240. If the CT Rate is set as 50, it means the primary current=secondary current x 50.





To use this meter for the delta grid, users also need to set the grid to 3P3W as follows:



From the set-up menu, use  and  buttons to select the system option. The screen will show the currently selected power supply.



Press  to enter the selection routine. The current selection will flash.

Use  and  buttons to select the required system option: 3P3W. Finally press  to confirm the selection.

#### 4. SDM630MCT from Growatt

SDM630MCT is a multi-function rail meter, it can accurately measure and display various parameters in 1P2W/3P3W/3P4W: voltage, current, active power, reactive power, frequency, imported energy, exported energy, total harmonics, etc. The meter is connected with external CTs and suitable for various high and low voltage power grids. Its RS485 communication port with Modbus RTU protocol supports remote monitoring and control.

Key Parameters	
Rated voltage	3X230/400V
Reference frequency	50Hz/60Hz
Input current	<5A
Rated temperature	-25℃~+55℃
Communication	RS485 output for Modbus RTU
Baud rate	9600
Pulse	3200imp/kWh
Sealing	IP51 (indoor)

The meter issued by Growatt do not come with CTs, and the customer needs to purchase CTs separately. Users can choose the CT specification for 250/5A, 600/5A, 1200/5A or 2000/5A according to the greater of the PV's maximum power generation and the load's maximum power consumption when placing an order.



The SDM630MCT is wired in the same way as the SDM630MCT V2 for delta grids, so it will not be repeated here.

The rated current of the secondary circuit should be set as 5A, i.e. CT2=5A. The rated current of the primary circuit is according to the actual CT specification purchased, i.e. CT Rate=50, 120, 240 or 400 (can be set in the range of 0001~2000). If the CT Rate is set as 50, it means the primary current=secondary current x 50.





To use this meter for the delta grid, users also need to set the grid to 3P3W as follows:



From the set-up menu, use  and  buttons to select the system option. The screen will show the currently selected power supply.



Press  to enter the selection routine. The current selection will flash.

Use  and  buttons to select the required system option: 3P3W. Finally press  to confirm the selection.