

# Sigenergy Energy Solution



SIGENERGY

Markus Nyberg

Solution Manager Nordics

+46 (0)760 0268 03

[Markus.Nyberg@sigenergy.com](mailto:Markus.Nyberg@sigenergy.com)

# One step at a time, strengthen our global presence



2022.05.24  
Sigenenergy established

2022.07  
Investment from Hillhouse Capital & Walden International

2022.12  
Investment from V.Fund & Eastern Bell Capital

2023.04  
SigenStor Shipment to targeted markets

2023.06  
Global brand & product launch

2023.09  
U.S. brand & product launch

2023.12  
Product scale shipment, employees 500+

2024.06  
Product and Solution Launch in China

2024.12  
SigenStack Shipment to targeted markets

2024.08  
Product and Solution Launch in Latin America

2025.02  
Product and Solution Launch in Japan

1000+

Estimated Employee  
By end of 2024

50%

R&D personnel

390+

Applied patents  
by DEC. 2024

# 3<sup>rd</sup> gen. Solution is Here: Solar+ESS+EV Charing

Technology-Driven Progress, Market-Driven Transformation

3

2023 - Future

## Third-Generation: High Integration



- Inverter tech. development reaches a bottleneck phase
- ESS tech. becomes mature, and explosive ESS demand
- Long-term demand for EV charging infrastructure
- Distributed energy scenarios take the lead

Now

Reimagine with **native technology** rather than expanding with technical extensions

2

2014 - 2021

## Second-Generation: Solar + Separated ESS



HUAWEI

**Exclusive Market Share Surpasses 23% in 2020**



Multiple MPPT, No Fuse, No Fans, Smart O&M...

And battery ready for future expansion

1

1991 - 2011

## First-Generation: Solar ONLY



**Maintaining a Global Market Share of over 30%**

The first string inverter was introduced in 1991

The first central inverter was launched in 2003

# Powering Homes, Leading the World

SigenStor: A Global Star in Residential ESS Market

Take the leading position in the market

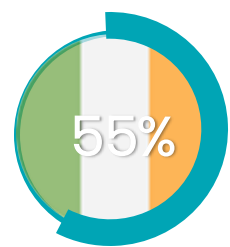

Ireland <sup>1</sup>

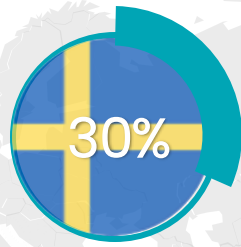

Sweden <sup>2</sup>

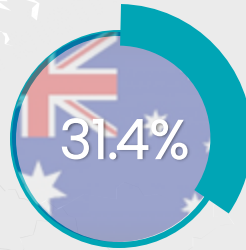

Australia <sup>3</sup>

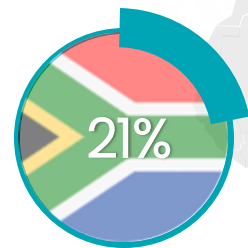

South Africa <sup>4</sup>

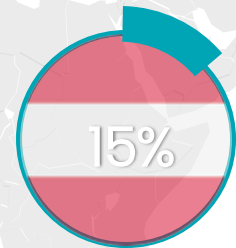

Austria <sup>5</sup>

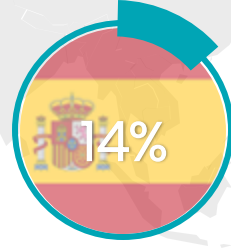

Spain <sup>1</sup>

No.1 global shipment volume  
of stackable distributed PV & storage integrated solutions

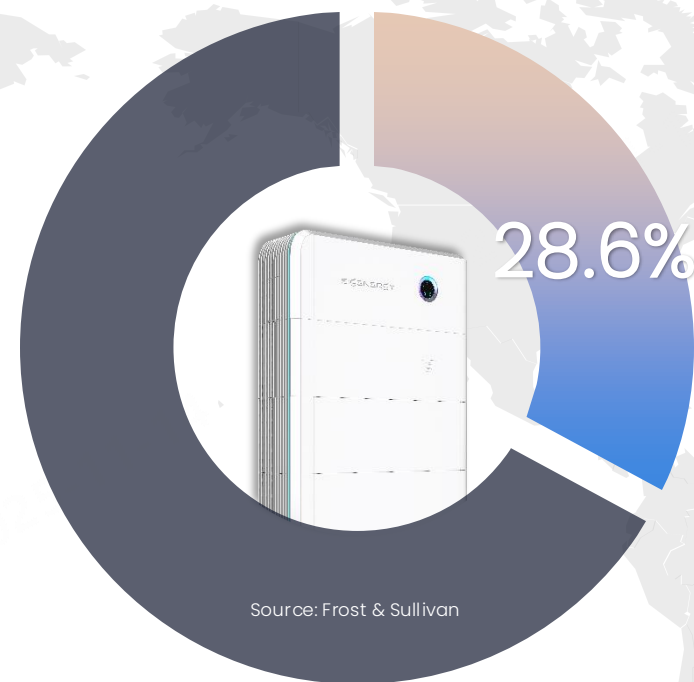

Source: Frost & Sullivan

Data sources:

1. Calculated based on customs data;
2. Based on the internal data of the Swedish Solar Energy Association (Svensk Solenergi);
3. Based on the report of SUNWIZ, a third-party authoritative organization in the Australian photovoltaic market;
4. Based on the data statistics of the largest distribution partner in South Africa;
5. Based on the official data of the Austrian government.

# Sigenenergy, Bring the New-generation ESS

Combing integrated, smart system with ultra safety to improve user-experience

## Highly integrated

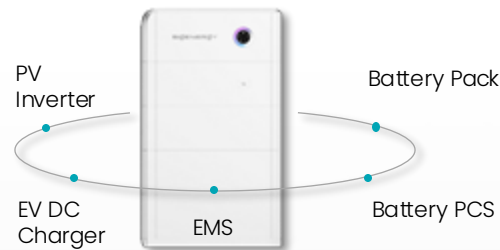

### SigenStor

World-first 5-in-One energy system

## Fully Intelligent



### mySigen App

World-first integrated with GPT-4o

## User Experience - oriented

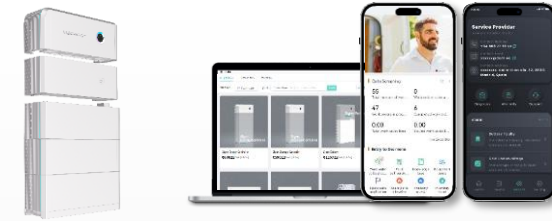

### Simple & interactive

Stackable installation, trackable user friendly

5-layer battery protection  
5-layer system protection

Device safety protection

System safety protection

Personal safety protection

Data security protection



GDPR



ADPPA

CCPA

CPRA

ISO27001

## Ultra Safe

# Five-in-One

Simple Design, Powerful Function

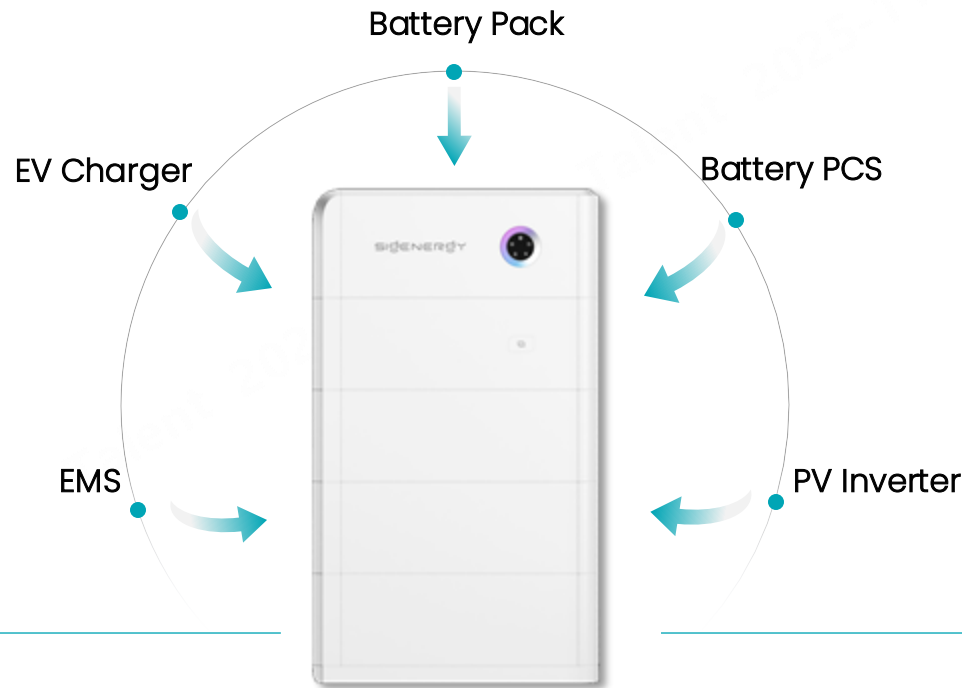

Compatible with different scenarios

PV+ Energy Storage system

AC Coupled Storage system

PV + Energy Storage + EV Charging system

Off-grid system



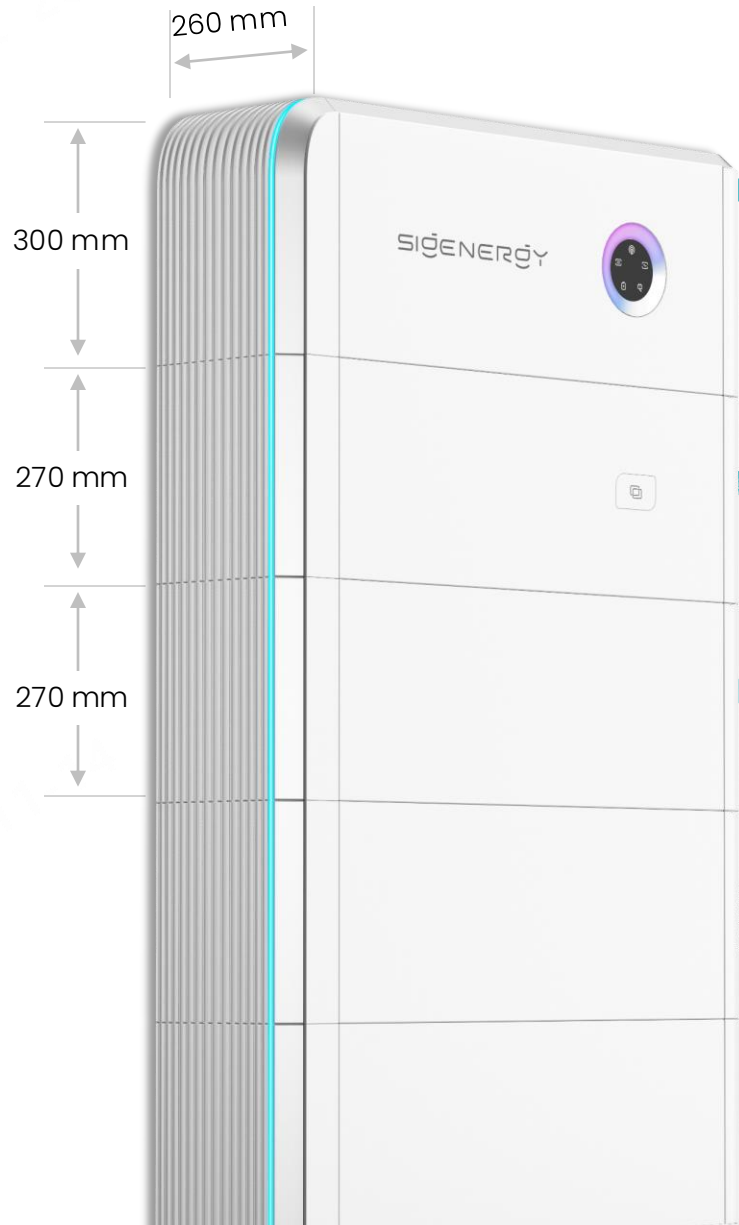

### Sigen Energy Controller for solar + storage system

Three phase grid connection (kw)

5.0	6.0	8.0	10.0	12.0	15.0	17.0	20.0	25.0	30.0
-----	-----	-----	------	------	------	------	------	------	------

### Sigen EV DC Charging Module (kw)

Ready for V2X

12.5	25
------	----

### Sigen Battery (kWh)

6.0	10.0
-----	------

Support **1 – 6** batteries combined for a single stack



\*Models in blue are only available in specific countries.

# Simple & Fast Installation

Do more business with less time per install, leave simplicity for installers

1 Quick connectors  
**15 mins** Installation



2 Auto-Networking  
**5 mins** commissioning

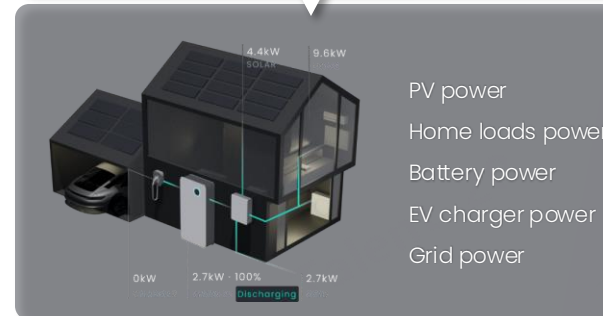
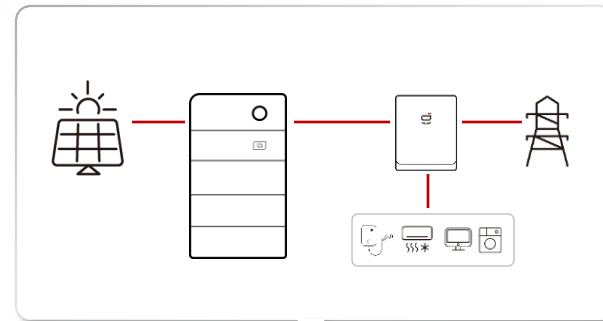

3 One-click diagnosis  
**Free from** rectification

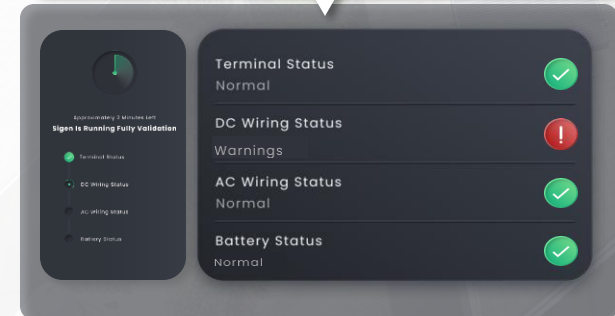
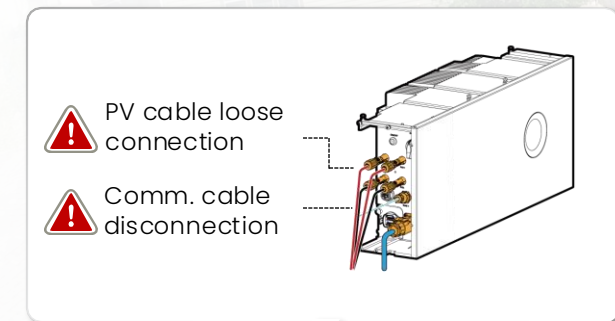

# All-round Safety Protection

Comprehensive protection, from battery cell level to system level

5

## Layers of Battery Protection

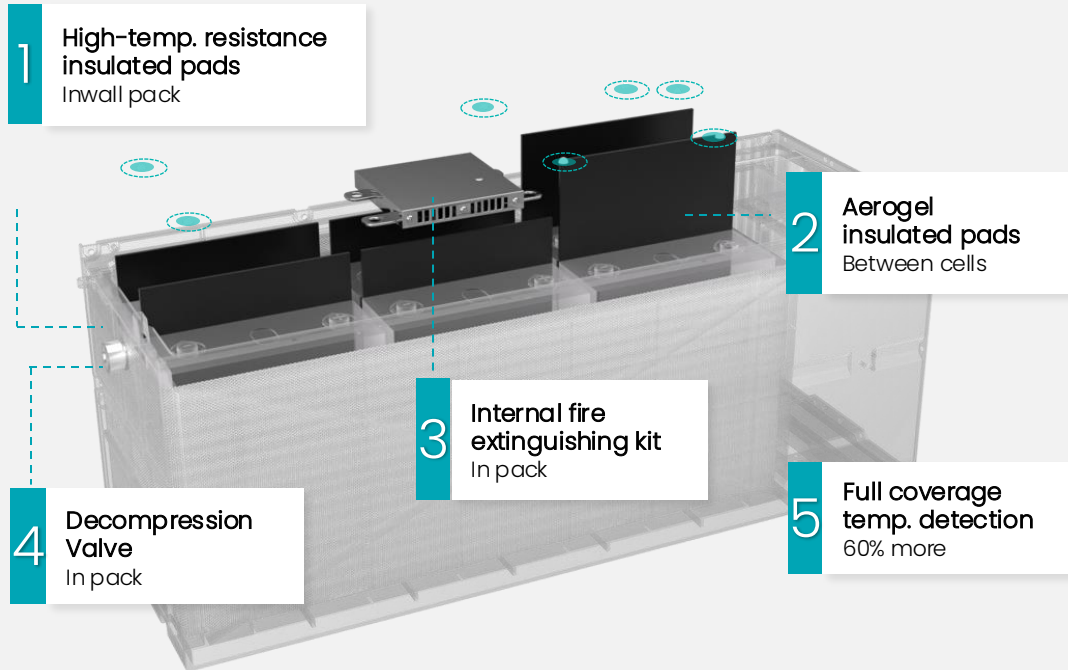

5

## Layers of System Protection

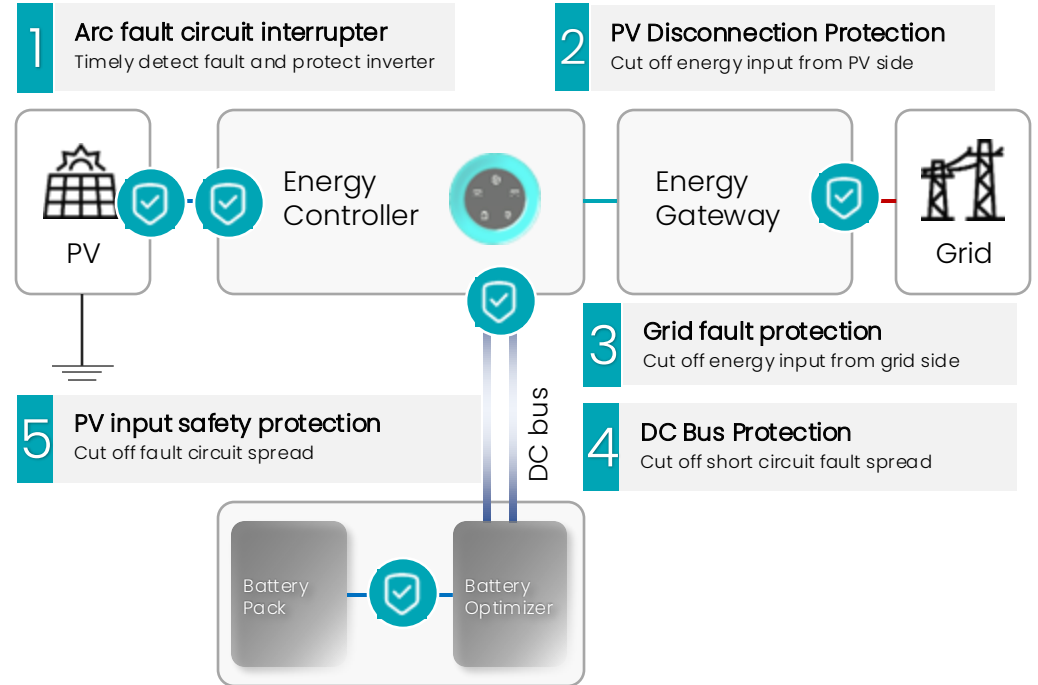

# Granular Battery Management

Built-in optimizer in each pack, designed in parallel connection

Packs Connection in Series

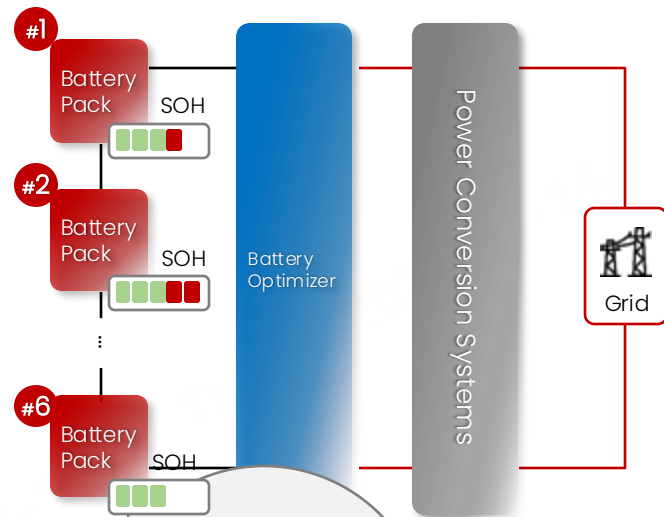

Packs Connection in Parallel

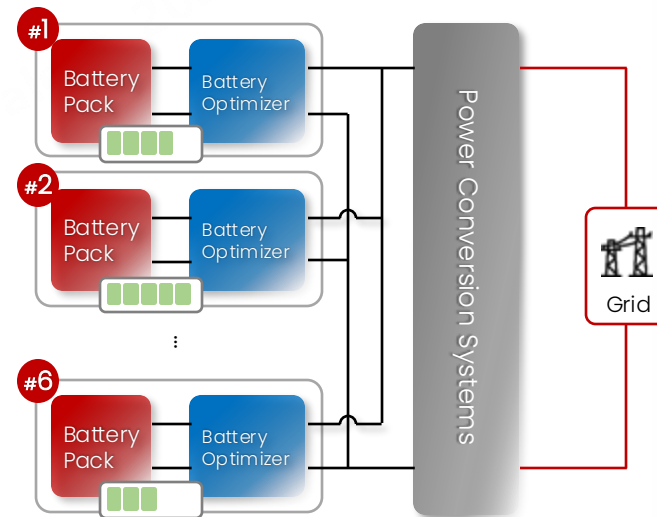

Better battery equalization

Flexible mix of packs among different **Battery SOH / SOC** or different cell **modes**



# Reliable Sigen EV AC Charger

High environmental adaptability, peace-of-mind for most environments

## IK10 Impact Resistance

Industry's highest impact resistance standard



20

joules of impact

Or can bear



5 kg

drop from

0.4 m

## IP65 protection



Sigenenergy  
Worry-free  
outdoor use

VS



Others  
Need rain cover for  
outdoor use

## TypeA RCD

Industry's highest protection standard



Integrated with  
30 mA AC RCD



Integrated with  
6 mA DC RCD



No need to buy extra RCD

## No power derating at high altitudes and temperature

55°C/4000m extreme environments



Sigenenergy: no reduction  
22 kW full power charging

VS

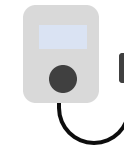

Others: reduction  
10 kW low power charging

# World-first Integrated DC Charger

More powerful systems & abundant low-cost energy for electric vehicles



## Max 25 kW DC Charging

\* The actual available mileage after charging 1 hour

SigenStor EVDC 25 kW<sup>1,2</sup>  130 km

Traditional EV Charger 7 kW  40 km

Charging a 75 kWh EV from 10% to 90%<sup>2</sup> ▶ **2.5** hours

## V2X Ready

**V2H:** More backup power for home



**V2G:** For peak shaving and VPP dispatch

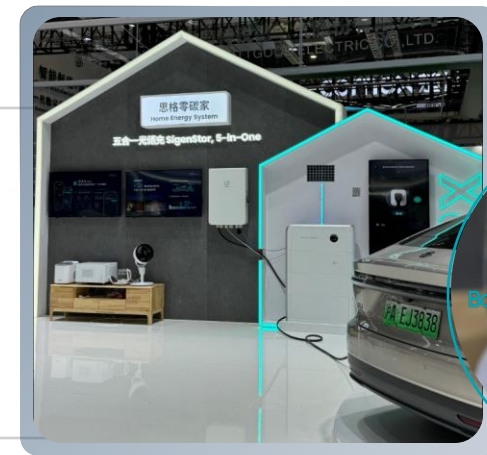

◀ **V2X @2024 SNEC**



1. Refer to the realistic consumption per 100km for a compact class EV, data sourced by P3 Charging Index Report 2022  
2. SigenStor EC 25 kW module with SigenStor EVDC Charging module as an example

# Worry-free Energy Usage

Auto switch to backup power in a flash

**0 ms** load-side disruption

Whole home backup supported

vs

The power outage lasts for **seconds**

Only support **partial home backup**

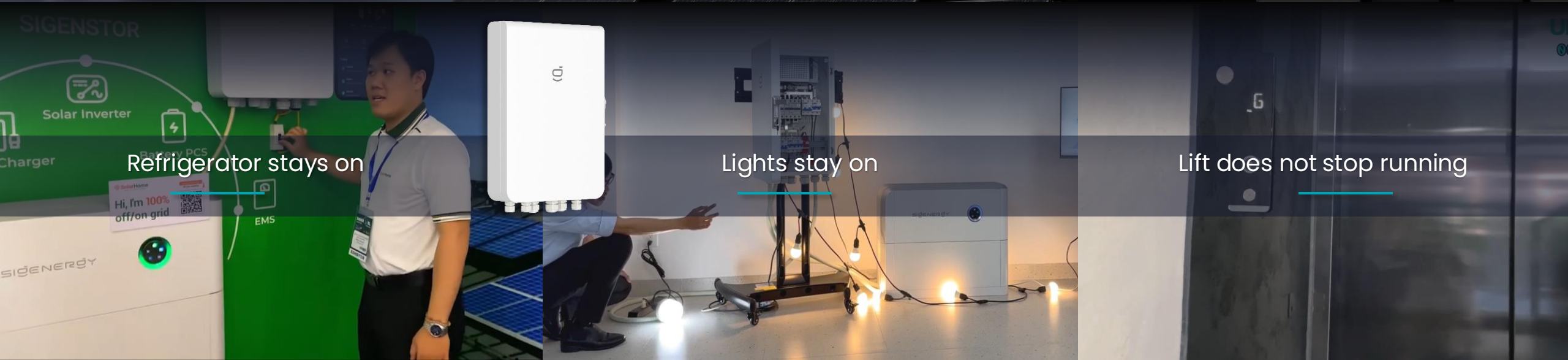

# New Sigen Hybrid Inverter

Single phase /kW

2.0

3.0

3.6

4.0

4.6

5.0

6.0

<25dB

Super silent

99mm

Slimmest design



Three phase /kW

3.0

4.0

5.0

6.0

8.0

10.0

12.0

99.0%

Highest Max. Efficiency  
Three phase

IP66

Protection rating

# Future-Proof with On-Demand Expansion

**1 Start with solar only**  
Reduce electricity costs

Sigen Hybrid



**2 Add storage later**  
Green energy at night

Sigen Hybrid



Sigen Battery



**3 Form a Micro - grid**  
Never feel the power failure

Sigen Hybrid



Sigen Gateway

Sigen Battery



# Advanced & digitalized manufacturing

## Quality tracking

throughout whole life cycle

- Incoming materials
- Manufacturing
- Product operation

## Improved Efficiency

throughout whole manufac. flow

- Plan mgmt.
- Manufacturing mgmt.
- Equipment mgmt.



Cell thickness detection



Increase battery cell life cycle

Laser Cleaning



Improve welding yields

IPG Ring Spot Laser



Increase weld yield by 2%

Automatic Gluing Line



Ensure heat dissipation perf.

# mySigen App,

Intelligent energy management within touches

## More intelligent

World-first GPT-4o integrated AI assistant  
AI mode with dynamic tariff, savings maximized  
More smart loads accessible, shelly supported

## More friendly

10s refresh energy flow to track energy usage  
Cell-level real-time info. available  
Multiple modes for tailored needs

### Sigen AI Mode

#### Revenue Increase

€31.12	€61.31	€127.05
This Month	This Year	Lifetime
70kWh	1.31 MWh	44.3 MWh

May 2023

#### Revenue Comparison

Sigen AI Mode Original Revenue

### Light language Setting

Color

0° 360°



### Real-time Monitoring of System Status

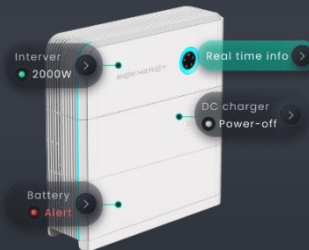

### Sigen Shield

3D view of battery safety

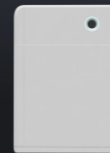

### GPT-4o Chatbot Integrated



### One click-diagnosis for System Health Check

Battery Terminal Connection  
Normal



### Smart load control

Manage smart devices  
On one platform

Add System Device  
Add Sigen System Device



# GPT-4o Empowered Intelligent Service

Provide speedy responses to users' inquiries and requirements in real-time

After-sales engineer

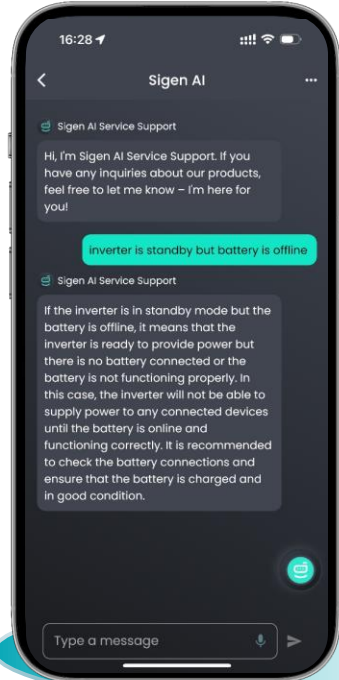

24/7 fast support

Sigen AI provides instantaneous responses to any issues you encounter using the Sigen energy system.

Home energy analyst

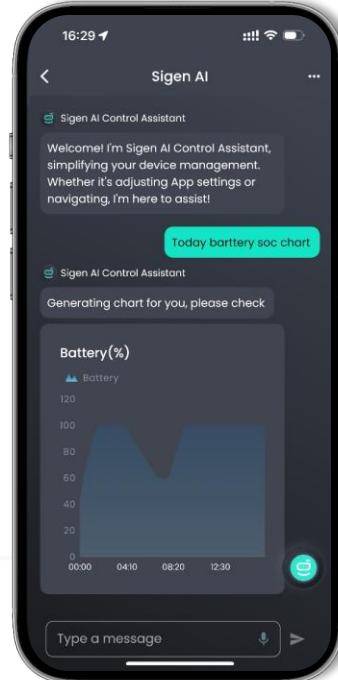

Accurate insights

Sigen AI relies on data stored in the Sigen Cloud to help you analyze your energy consumption and generation.

Device mgmt. assistant

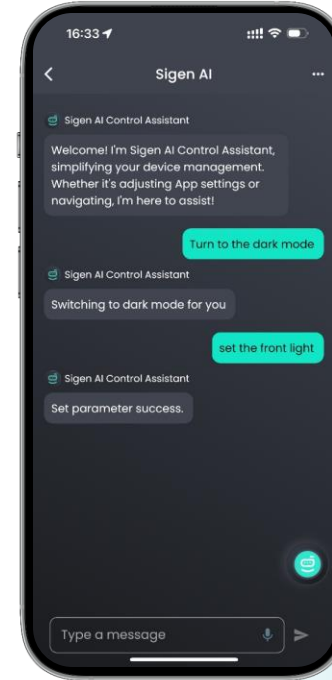

Manage home devices

Sigen AI can obey your instructions to manage your home devices, such as the Sigen EV AC charger, Sigen Gateway, heat pumps, generators, etc.



All local languages supported



# Multiple working modes flexibly match user needs

## Flexibly choose your ideal operation mode

### 1 Sigen AI Mode Customize home energy solutions Maximize electricity savings

Operation data Local tariff Humidity  
 Irradiance Cloud amount Temperature  
 Temporal features Association features

XGBoost forecast of tomorrow  
 Neural network forecast of today

Full range of forecasts  
 Load consumption Energy analysis  
 Power generation Electricity price  
 Revenue comparison

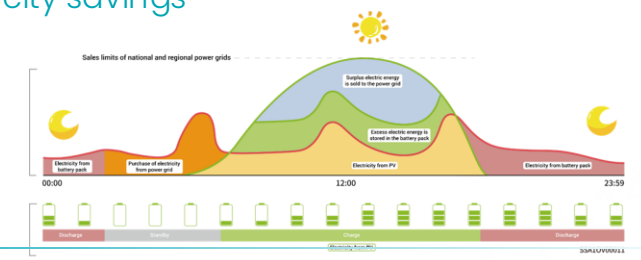

19 Application Countries  
 22% Revenue increase at a UK power station

### 2 TOU (Time of Use) Mode

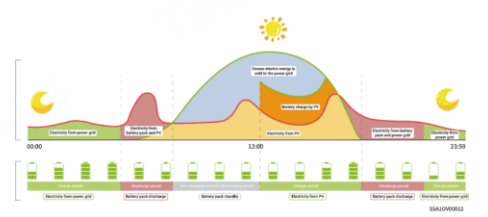

Peak valley arbitrage  
 Maximize returns

### 3 Peak Shaving Mode

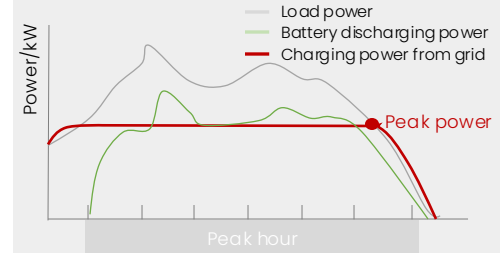

Composition of bill

Reduced demand Charge	Limit peak power
Other fees (e.g., tax)	Utilize ESS to meet peak loads
Basic energy charges	Reduce demand charge

### 4 Max. self-consumption

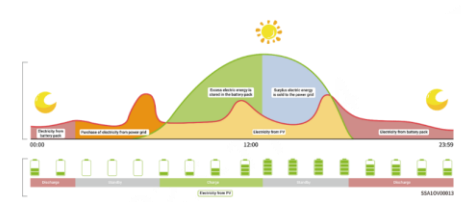

### 5 Fully Fed to Grid

100%

Maximize the PV energy for grid connection.

### 6 Load Shedding

21:00 ~ 23:00 19:00 ~ 21:00

Automatically obtain power outage times, and charge ESS in advance.

# Sigenergy Energy Solution



SIGENERGY

Anders Hellström

Sales Director Nordics

+46 (0)760 23 21 50

[Anders.hellstrom@sigenergy.com](mailto:Anders.hellstrom@sigenergy.com)

# Overview of C&I Product Family & more interesting news are coming

**Sigen PV Inverter (on-grid)**  
Sigen PV 50/60/80/100/110/125M1



**Available**

**SigenStack**

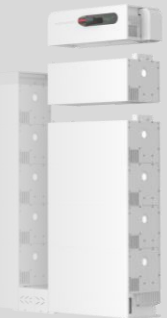

▶ **SigenStack BC**  
Battery Controller

▶ **SigenStack BAT**  
SigenStack BAT 12.0

**Available**

**SigenStor**

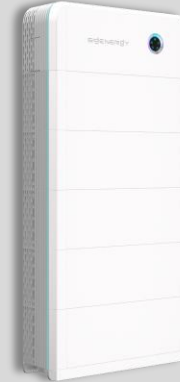

**SigenStor EC**  
Energy Controller

**SigenStor BAT**  
SigenStor BAT 6.0 / 10.0

**Available**

**Sigen Comm. Bridge**  
Sigen CommBridge

**Available**

**Sigen Hybrid Inverter (on-grid)**  
Sigen PV 50/60/80/100/110/125M1-HYA



**125 kW HYA ready in Sep. 2025**

**Sigen Energy Gateway for HYB**

C600-B      C1600-B  
C1200-B    C2000-B  
                  C2400-B



**NEW** **NEW**

**Ready in Sep. 2025**

**Sigen Hybrid Inverter (on-/off-grid)**  
Sigen PV 50/60/80/100/110M1-HYB



**NEW**

**Ready in Sep. 2025**

**Sigen Energy Gateway for SigenStor**

C60-2  
C120-6  
C180-9  
C300-12  
C600  
C1200



**Available**

**Sigen Comm. Module**  
Sigen CommMod



**Sigen Power Sensor**

Sigen Sensor TP-CT100  
Sigen Sensor TP-CT300  
Sigen Sensor TP-CT600  
Sigen Sensor TPX-CH  
Sigen Sensor TP-CT5



**Sigen Cloud MySigen App**



# SigenStack, Innovative Modular BESS Energy Solution

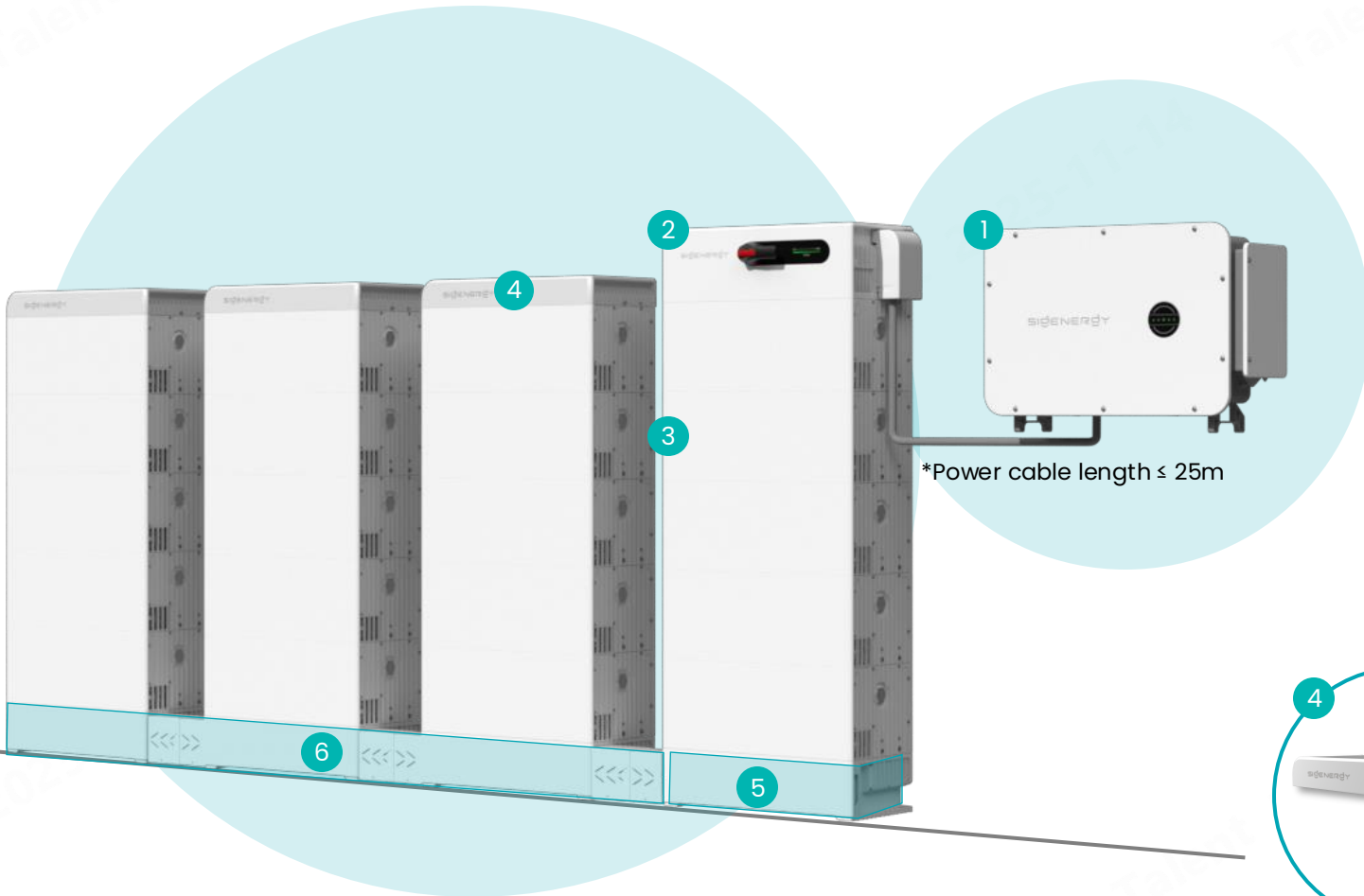

**1 Sigen Hybrid Inverter**  
50/60/80/100/110/125 kW



**2 Battery Controller**  
180 A Max. output current



**3 Battery Module**  
Model: SigenStack BAT 12.0  
12.06 kWh energy capacity per module  
4 ~ 21 modules connected per inverter

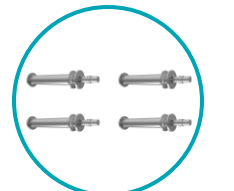
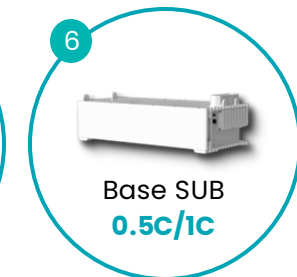
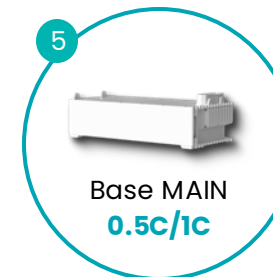

Handles  
1 inverter with 1 set  
recommended



# C&I Products in Action Globally Addressing Every Challenge



 **Farm**

Max. self consumption  
100 kW + 217 kWh



 **Fruit Warehouse**

Rooftop scenario  
100 kW + 300 kWh



 **Utility PV+BESS**

Quick installation  
10 MW + 20 MWh



 **Steel Factory**

Narrow space  
400 kW + 1 MWh



 **Machin Factory**

On/off-grid switch  
220 kW + 168 kWh

# Modular design

## Simpler site selection, smaller footprint

— SigenStack, fewer requirements on surroundings —

— Traditional cabinet ESS, Larger footprint —

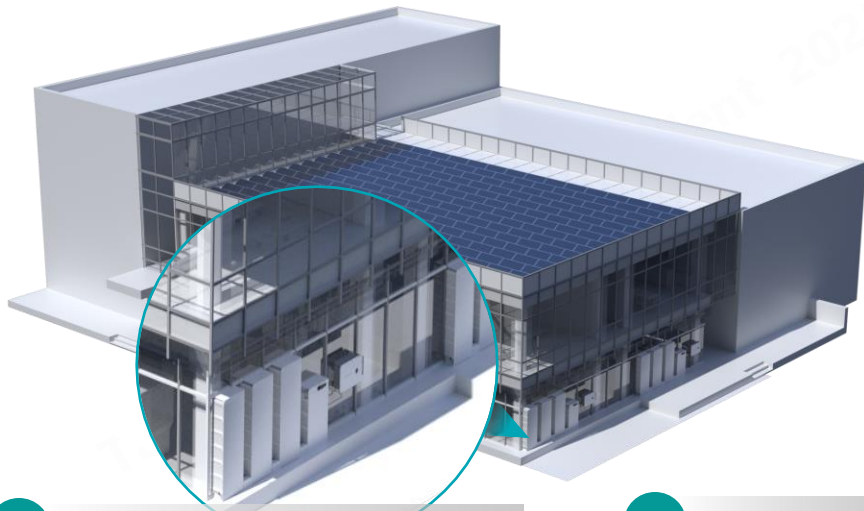

- ✓ No requirement for O&M access
- ✓ Save footprint
- ✓ Harmonize with the environment

**Integration with the buildings**

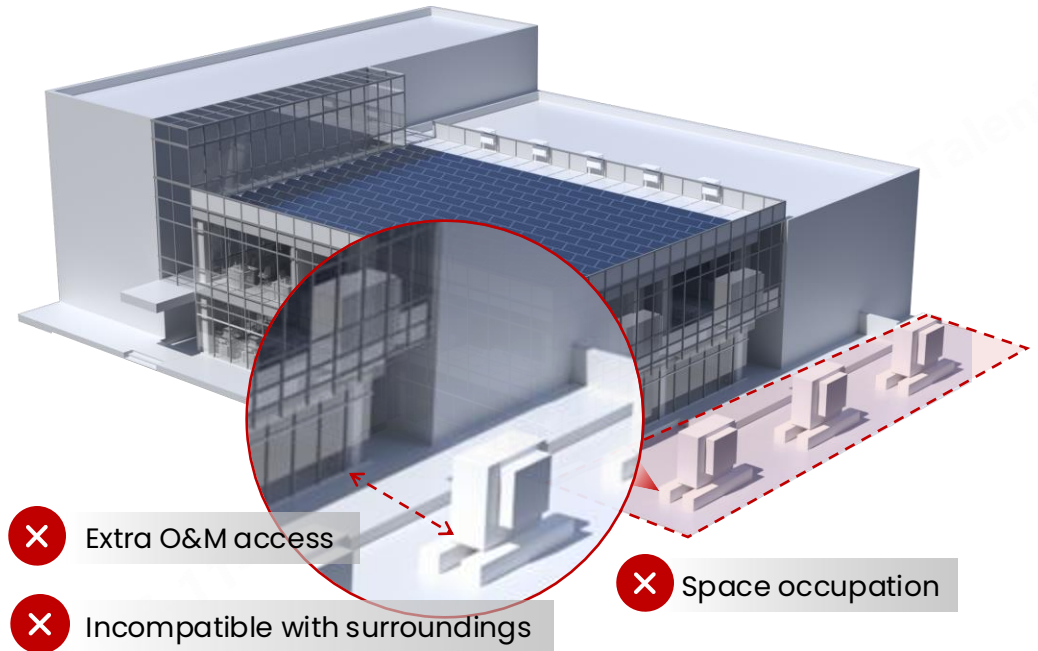

- ✗ Extra O&M access
- ✗ Incompatible with surroundings
- ✗ Space occupation

Need additional space **140 m<sup>2</sup>**

\*Calculation based 600 kWh ESS project

# Modular design, Flexible System Configuration, precise investment

## — SigenStack fully modular design —

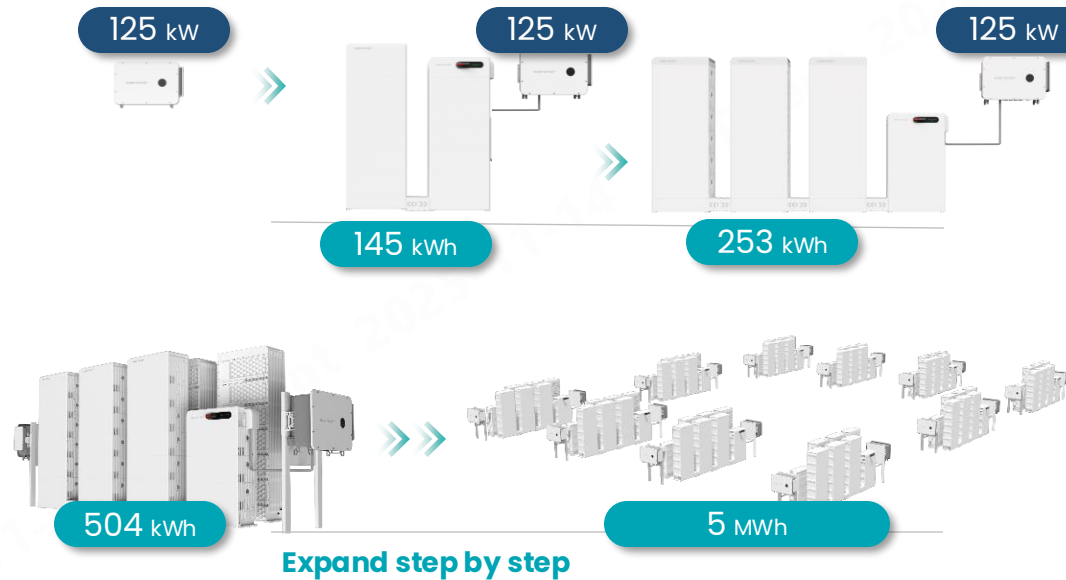

## — Traditional solar + ESS energy solutions —

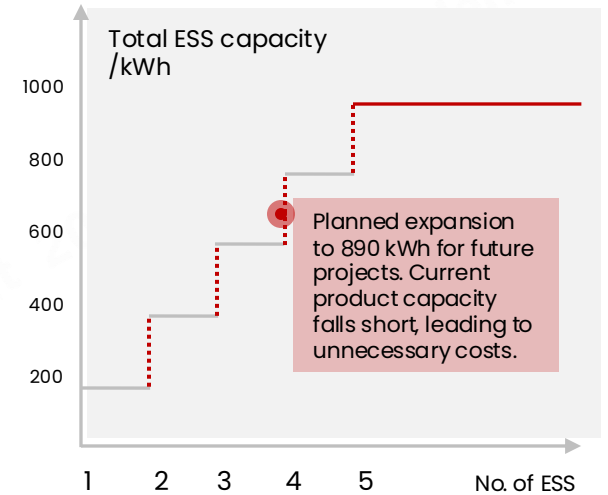
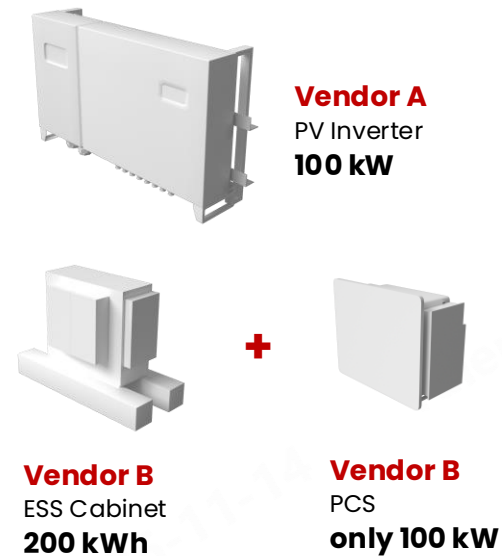

# Higher RTE efficiency with DC Coupling, save more, get more

## Sigenergy BESS Solution, DC coupling

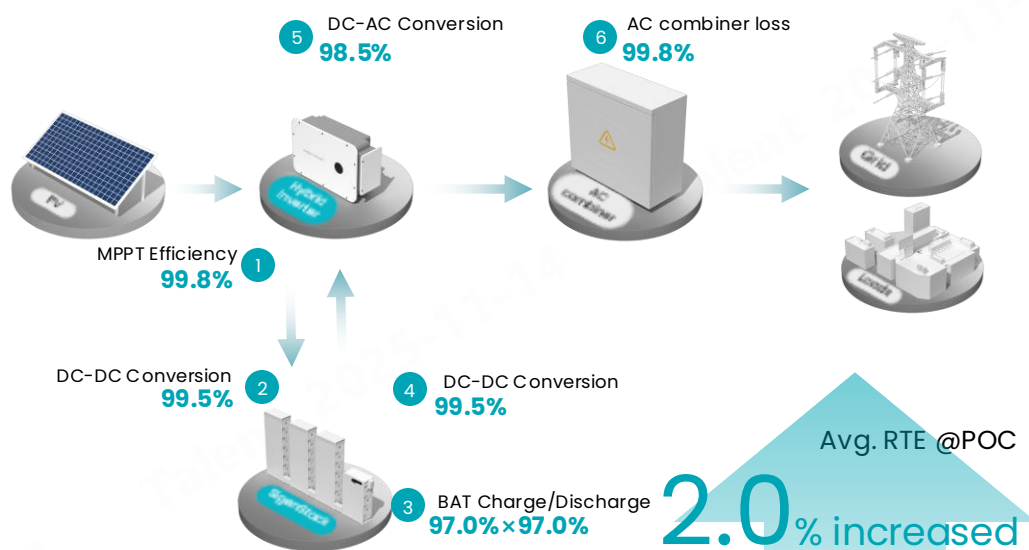

About **91%** RTE

\*calculation condition:  
PV capacity = 4 MWp  
PV power equivalent operating hours = 1500 hrs  
Percentage of PV power generation to ESS since AC clipping = 3%  
Electricity price = 0.3 Euros/kWh

## Traditional solution, AC coupling

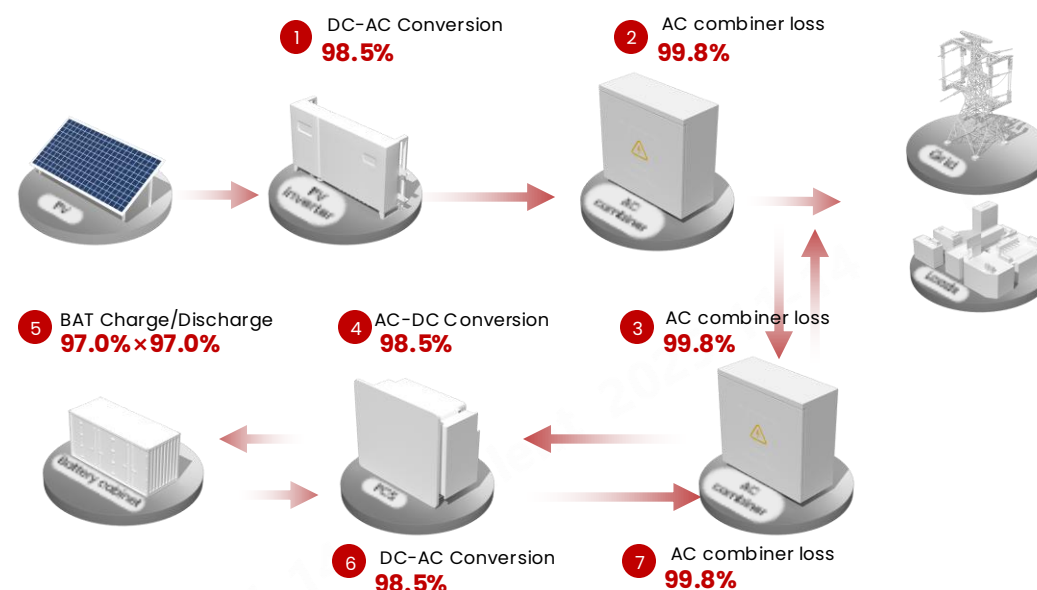

Complex system with high power loss

About **89%** RTE

# Active battery balancing, free of SOC calibration

## Active Balancing Function

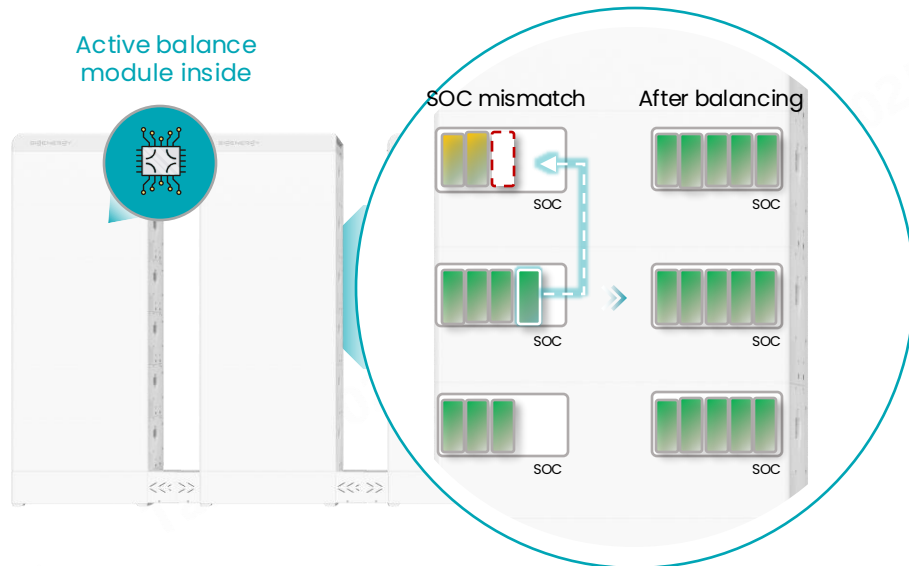

**SigenStack balancing capability**

**5** A balance current

**Free of SOC calibration**

**No manpower required**

## Traditional Solution

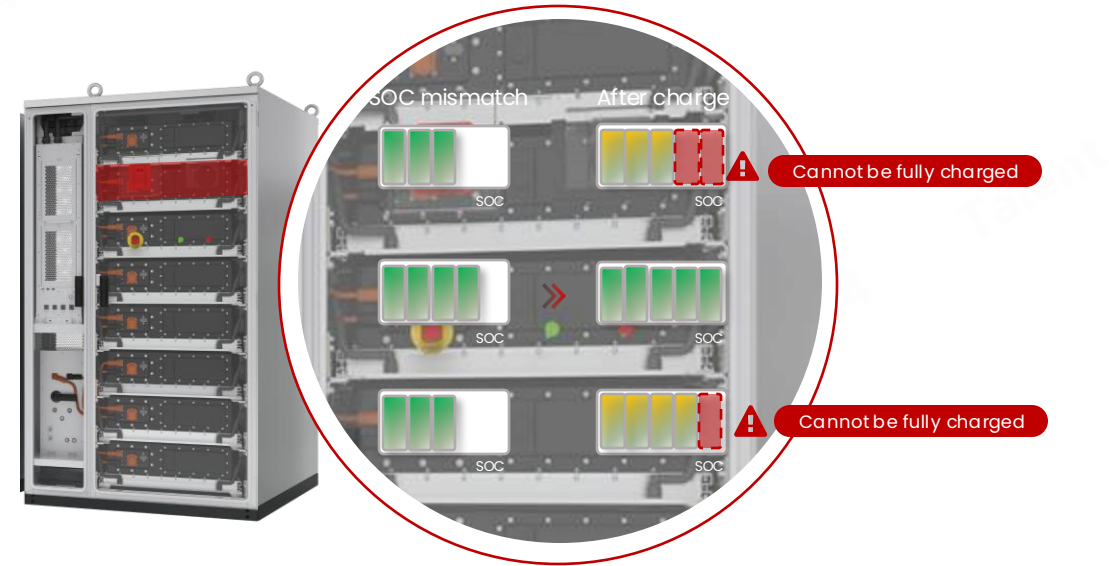

**Others balancing capability**

**2~3** A balance current

**Without Active Balancing**

**€5,760**

Annual Cost



Monthly SOC Calibration



Need technical staff



Need charge & discharge machine

# Fast commissioning with system self-networking

— SigenStack, ultra-fast commissioning —

**Auto** networking



— Traditional solutions, time-consuming  
with one-by-one devices connecting —



**Need supervisor service**

Project site requires professional  
installation guidance

Onsite technical disclosure & training

Installation and construction guide

Grid-connection commissioning guide

...

About **€3,840** For 1 MWh project

# Free of complex and regular cabinet ESS O&M

## SigenStack, High protection rating



**6X: No ingress of dust;  
complete protection against  
contact**

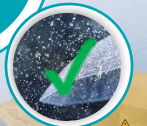

**X6: Protection from water,  
even from powerful jets of  
water**

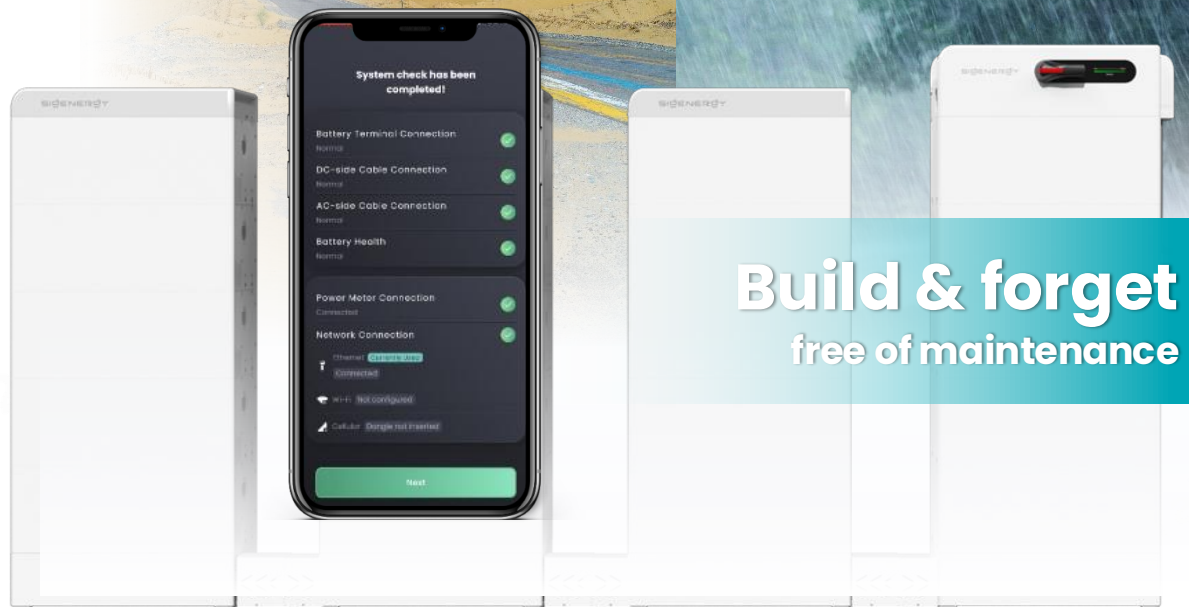

**Build & forget**  
free of maintenance

## Multiple check items brings high OPEX



Check per  
**6 months**

Air conditioner

Smoke sensors

Power supply

Temp. sensors

Check per  
**12 months**

Air inlet/outlet

Wire connection

Safety function

Software version

Check per  
**12 months**

Earthing

SPD

Fan

Screw

Check per  
**24 months**

Battery capacity

Internal resistance

Switch box

Refrigerant

Annual Maintenance Cost

**€22,610**

ESS fire safety check

Check per  
**1 months**

*\*Take a 1000 kWh ESS (200 kWh cabinet x 5) as an example*

# Seamless on/off-grid switch No disruption to backup load during power outage

Sigenergy Seamless

Vendor AT 10 ms

Vendor S 20 ms

## Hold-up time of devices

Communication devices (router, switch)	10 ms
Precision device	10 ms
Computer	20 ms
Fans, pumps	30 ms
LED lights	41 ms

0 ms load-side disruption

Load operation may be interrupted

Sigenergy: no fluctuations on change over



vs

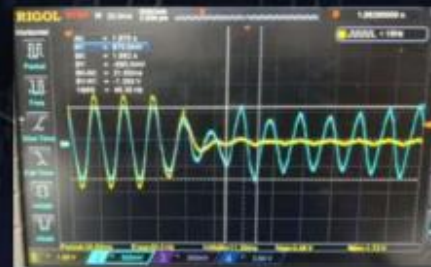

Others: >10 ms disruption time

# Pack-level safety protection, accurate safety control

## Pack-level fire extinguisher

## Cabinet-level fire extinguisher

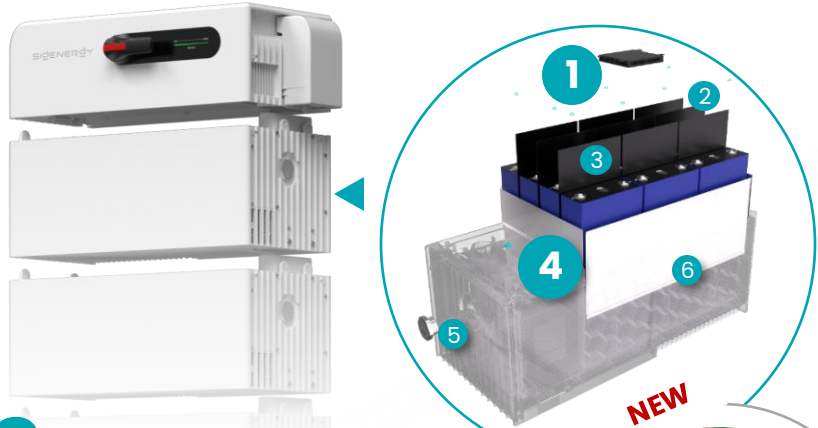

Fire suppression system  
per **12 kWh**

**6**-layer safety protection

- 1 Fire extinguishing kit
- 2 Full-coverage temp. detection
- 3 High-temp. resistant insulated pad
- 4 **Smoke Sensor**
- 5 Decompression valve
- 6 Insulation and heat isolation layer

**NEW**



**Smoke Sensor**  
The real-time detection of thermal runaway reduces response time by **60** seconds



Fire suppression system  
per **200 kWh**

- Fire extinguisher

 **Thermal runaway**  
will spread throughout the whole cabinet.



SIGENERGY

# Large-scale Fire Testing of SigenStack: Burning Without Spreading, Risks Without Spilling

## Extreme thermal runaway test

Manual triggering thermal runaway of one battery pack **under extreme conditions\***

*\*All active safety protections are removed. The front and rear stacks are spaced 20cm apart, and the left and right stacks are spaced 30cm apart.*



Hubei, China



March, 2025





SIGENERGY

## Large-scale Fire Testing of SigenStack: Burning Without Spreading, Risks Without Spilling

**No** fire propagation pack-to-pack

Even with "zero" spacing between packs, all battery packs are structurally intact. Temperature of adjacent packs stays < 30 °C

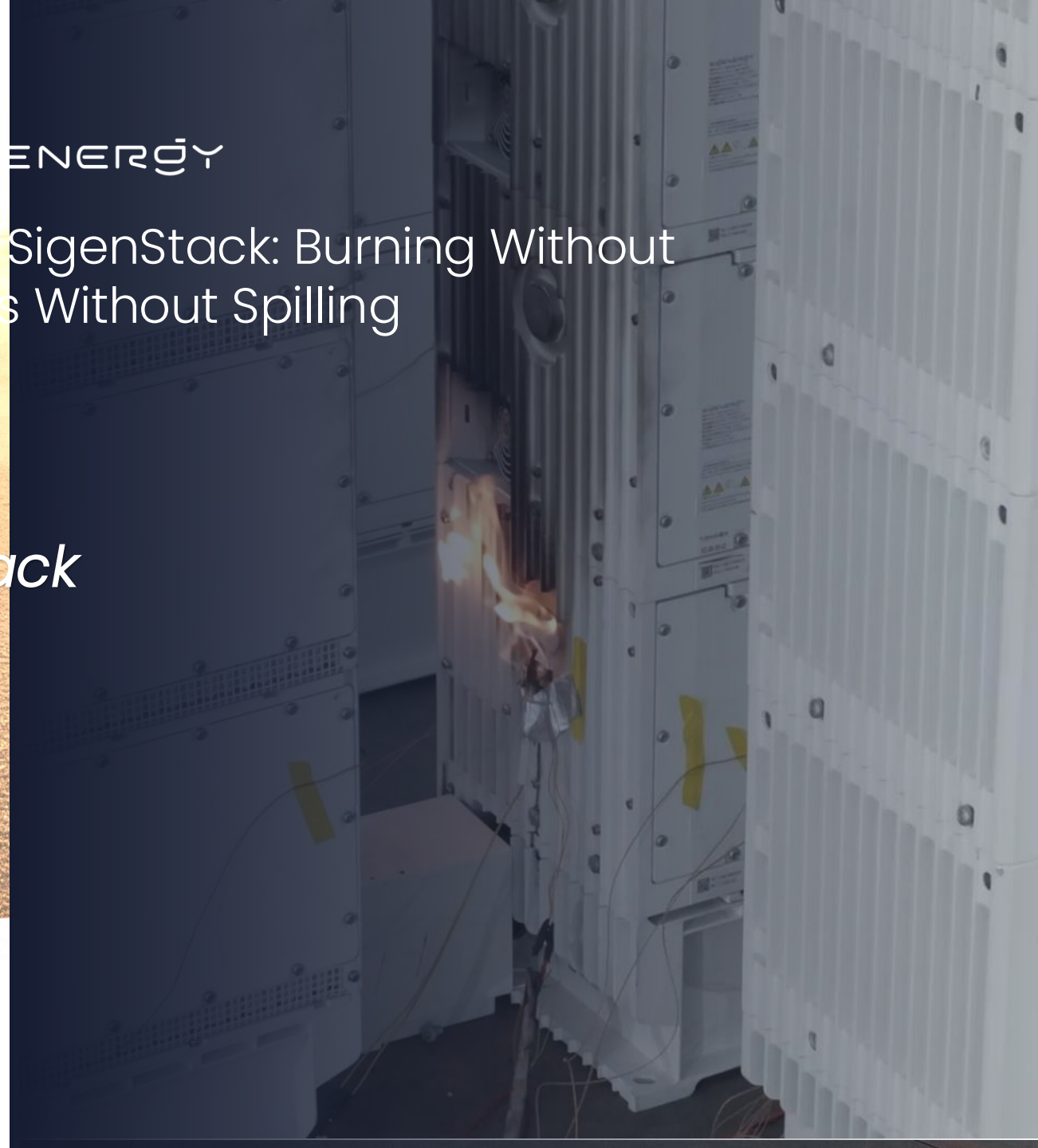



SIGENERGY

## Large-scale Fire Testing of SigenStack: Burning Without Spreading, Risks Without Spilling

**No** fire propagation stack-to-stack

Fully simulating actual installation, **no electrical breakdown or battery short circuit**. Temperature of adjacent stacks stays < 30 °C

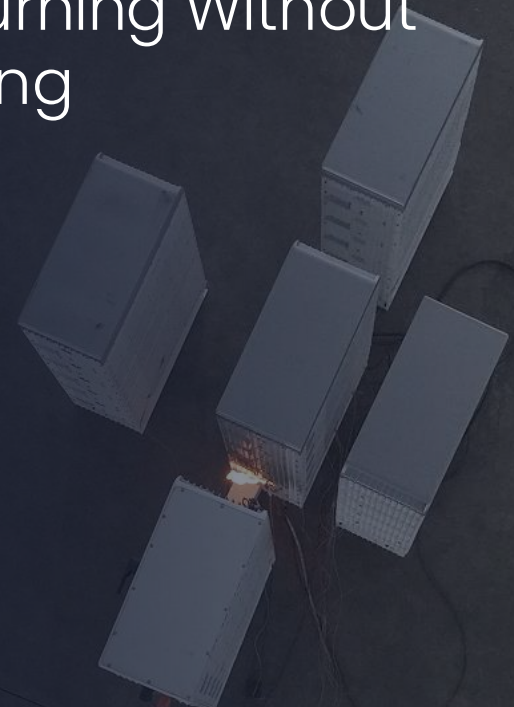

# Free of datalogger, improves comm. reliability

## Traditional comm. solutions

Additional Data logger/Dongle required,  
Additional Communication Node = Additional Failure Node

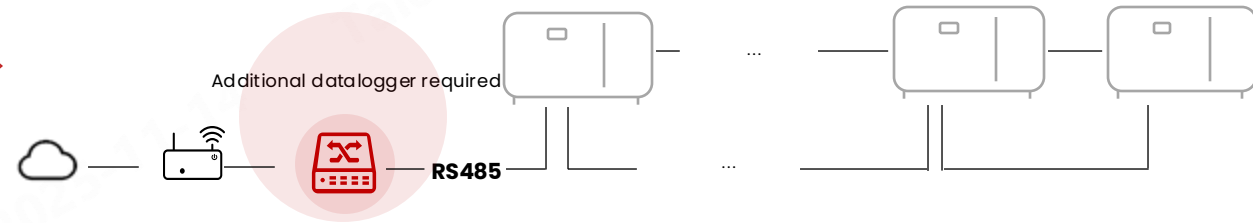

## Need datalogger, higher CAPEX.

Rooftop Solar  
500 kW



C&I projects totaling **100 MWac**

Require **200** datalogger  
**x 2000** EUR/unit

## Logger-Free comm. solutions

Reliable communication,  
any inverter can be the master



# An easier O&M platform for installers

## As installers, you can easily monitor and manage all systems

**1** O&M List  
Quick access to alert information

Error Device Type	Alert Name	Alert Info	Alert Cause	Error Device Type
102_4	Inverter AC side voltage abnormal	AC side under-voltage	AC side voltage below threshold	Inverter
102_5	Inverter AC side voltage abnormal	AC side under-frequency	AC side frequency below threshold	Inverter
400_3	Communication fault	AC power sensor communication error	AC side not connected to the gateway or electrician	System
100_1	Grid power outage	Grid power outage or AC switch turned off		Inverter
400_1	Communication fault	Gateway	Power communication error	System

**2** Systems List  
Clear display of all managed systems

System Name	System ID	Status	Country/Region	System Address	Grid Connection Time	Power Capacity
Common Wang	E3204920008	Offline	Australia	*** Stirling WA	2024-10-18 08:52	6.6 kW
0005	E32048270003	Offline	China	*** 79/18	2024-10-17 15:56:00	9 kW
Mark Cheeseman	E32048280043	Normal	New Zealand	*** 8882	2024-08-08 07:58:05	9.9 kW
Matthew S Page	E32048790058	Normal	Australia	*** 326	2024-07-19 10:12:49	16.3 kW
SolarhookingCarols	E32048700065	Offline	Australia	*** Beverly	2024-07-10 05:40:02	5 kW

**No.1** to support third-party inverter and smart loads mgmt. on one platform

**3** Check specific system  
Go insight any system for more...

**LinGang.NO.3**  
Normal On Grid

\*\*\* Pira Jitansa  
System Address  
2024-02-01  
Grid Connection Date  
42.1%  
Battery SOC

Real-time Information

0.07 kW  
Reactive Power of Grid  
Connection Point

0.01 kW  
Inverter Total Reactive Power

6.6 l  
Inver Power

5°C  
6.8 kW  
0 kW  
0.2 kW -42%  
SigneStar Charge  
6.6 kW  
GRID

Energy Balance (kWh)

Energy Value (¥)

44.72 Consumption

**4** Check specific device  
Easily explore operational data from any device

Basic Information Parameter Settings

SigneStar Status: Normal SN: CMU10A126C0136

Device list

SN	Device type	Status
I10A126C0136	SigneStar EC 5.0 SP	Normal
I10E226B0106	SigneStar BAT 5.0	Normal
I10E226B0108	SigneStar BAT 5.0	Normal

Real time info Refresh 19/10/2024 00:57:38

Status Normal Today's power gener. Active power 0.220 kW

Battery SOC Today's charging am. Discharge today 0.41 kWh

Reactive power 0.001 kW

DC total power

Real time

0.001 kW

Device parameter

Real-time Information Refresh 19/10/2024 00:57:38

Inverter side info			Grid side info		
Phase A	Phase B	Phase C	Phase A	Phase B	Phase C
Voltage 248.95 V	242.21 V	248.6 V	Voltage 248.9 V	242.4 V	242.4 V
Voltage Frequency 49.99 Hz	49.99 Hz	49.99 Hz	Current 1.76 A	1.23 A	1.2 A
Voltage Phase sequence	Phase sequence	Phase sequence	Active Power 0.295 kW	0.001 kW	0.044 kW
Reactive Power 0.087 kW	0.001 kW	0.006 kW	Reactive Power		
Min voltage in the past output			248.9 V	242.9 V	242.0 V
			Voltage Frequency		

# Sigenergy Energy Solution



SIGENERGY

Anders Hellström

Sales Director Nordics

+46 (0)760 23 21 50

[Anders.hellstrom@sigenergy.com](mailto:Anders.hellstrom@sigenergy.com)

# Lightweight Design, Save shipping & installation cost

## Lightweight body for easier installation

Easier to carry and install, saving installation labor costs



Weight **75 kg**

Dimension

**918/640/340 mm**

**19%**  
Less weight

**36%**  
Smaller size

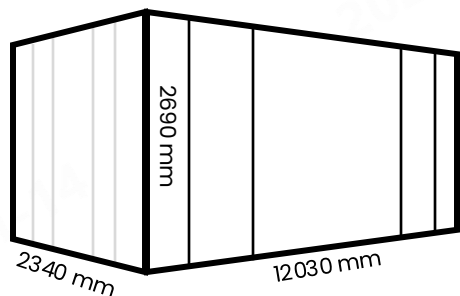

## Transport costs saving

Reduce transport costs by transporting more equipment in the same containers



x **165**



x **100**

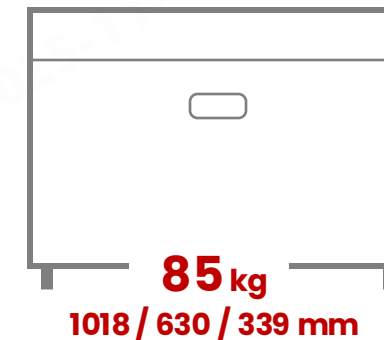
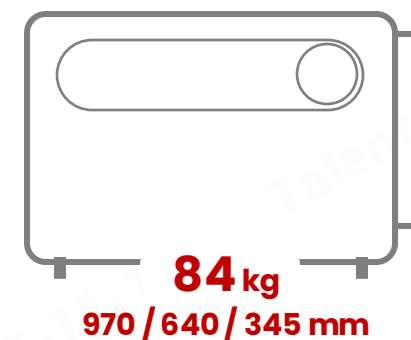
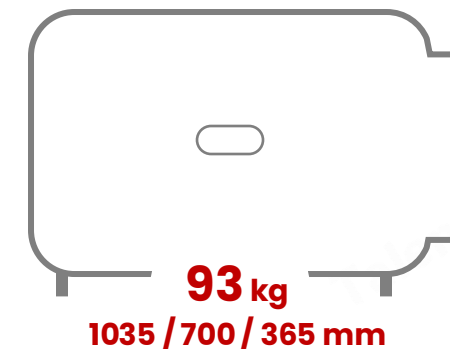
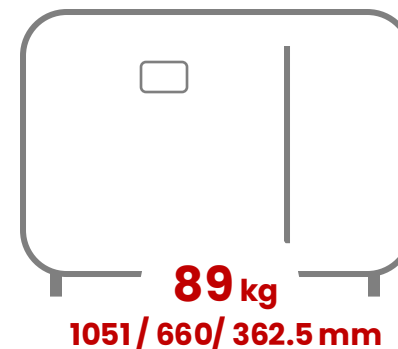

# SigenStack on-grid solution, large-scale PV+BESS

Any Sigen Hybrid Inverter can be a master unit – less than or equal to 100 inverters

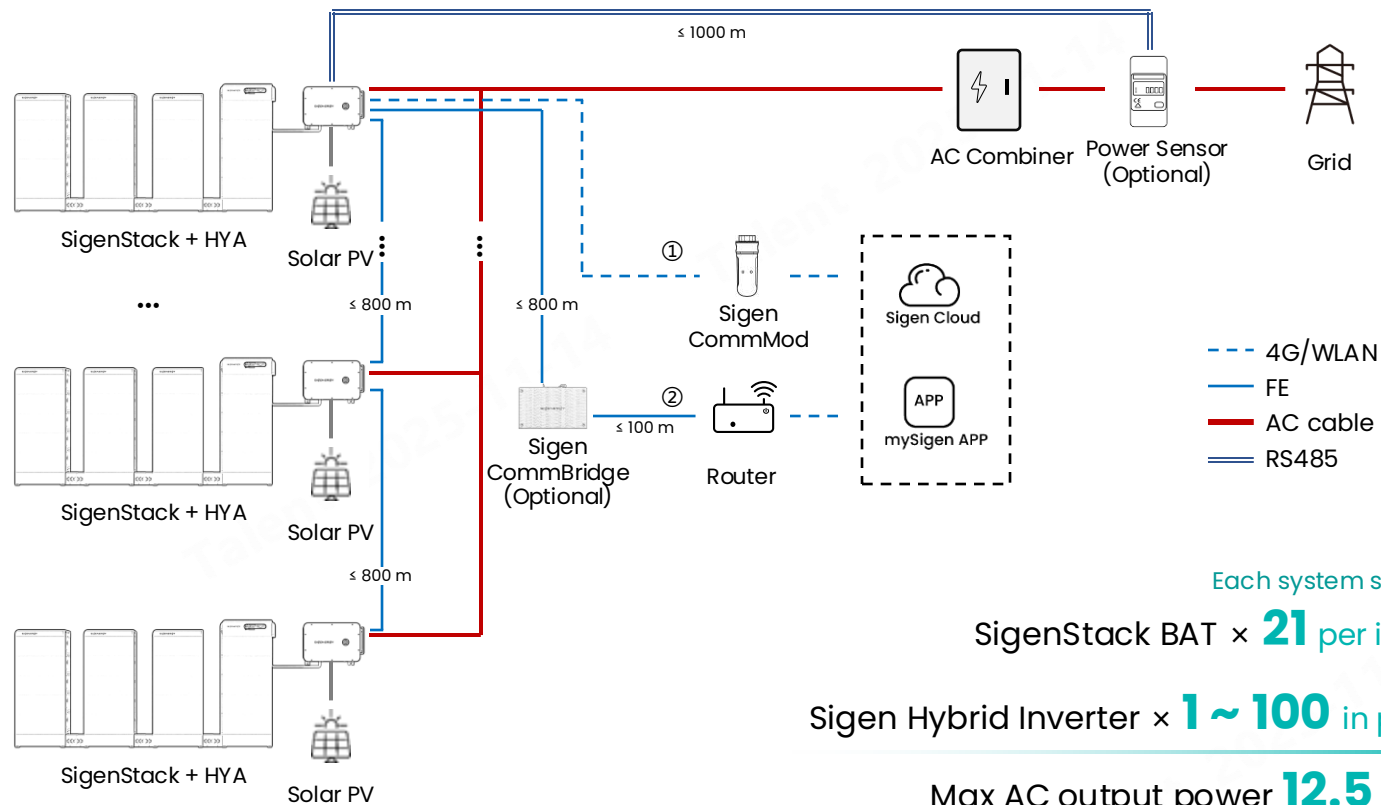

Communication distance:

RS485 cables  $\leq 1000\text{ m}$

FE cables  $\leq 800\text{ m}$

\*For communication with third party devices, FE  $\leq 100\text{ m}$

Each system supports :

SigenStack BAT  $\times 21$  per inverter

Sigen Hybrid Inverter  $\times 1 \sim 100$  in parallel

Max AC output power **12.5** MWac\*

Max. ESS capacity **25** MWh\*

\*Take Sigen Hybrid Inverter 125 kW & SigenStack BAT 12.0 as an example



Sigen Hybrid Inverter

Sigen PV 50/60/80/100/110/125MI-HYA



SigenStack

SigenStack BC M2-0.5C  
SigenStack BC M2-0.5C-BST  
SigenStack BC M2-IC-BST  
SigenStack BAT 12.0



Sigen Communication Module

Sigen CommBridge



Sigen Communication Module

Sigen CommMod



Sigen Power Sensor

Sigen Sensor TP-CT120-DH  
Sigen Sensor TP-CT300-DH  
Sigen Sensor TP-CT600-DH  
Sigen Sensor TPX-CH



# Super AFCI detection, Enables all-application scenarios

## Sigenergy software detection strategy

### 1 Feature fusion

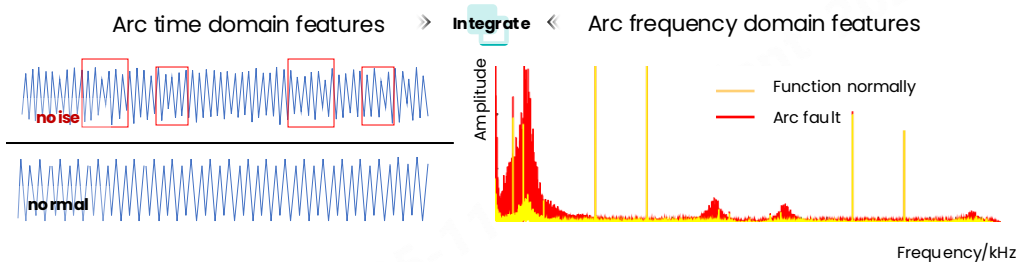

### 2 Algorithm fusion

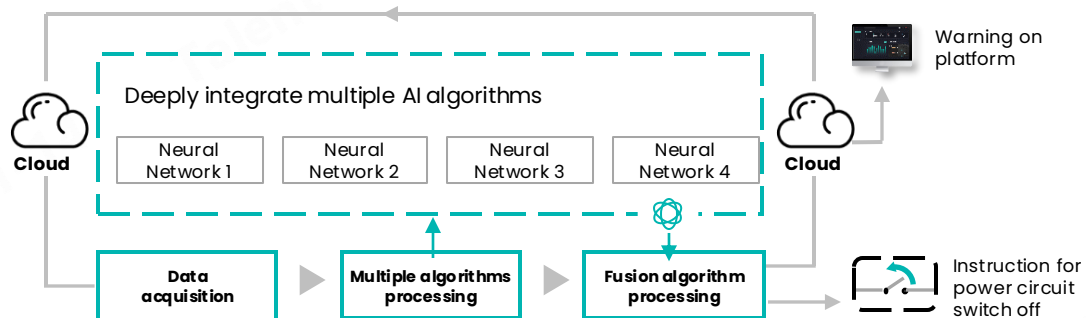

### Sigenergy solution

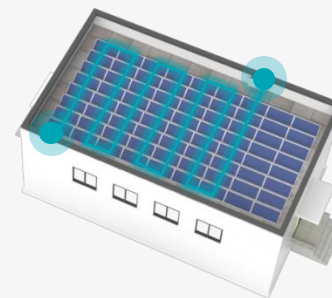

Detecting arc faults with  
**higher accuracy & speed**

**500<sub>m</sub>**

Max. detection distance\*

### Industry-leading solution



**450<sub>m</sub>**

Max. detection distance\*

### Others solution

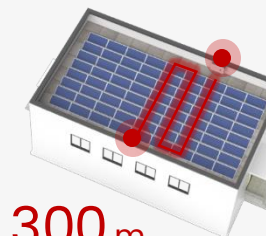

**300<sub>m</sub>**

Max. detection distance

\* Scenario-specific measured distances

# Basic Principles of Configuration

## Limitation of module number and height

4~21 modules per system

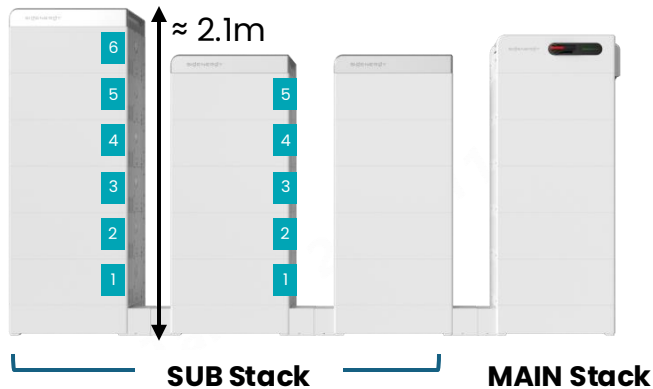

≤5 modules

For security and ease of O&M

6/7 modules

Should install with additional fixed structures

## What is Battery Controller ?



Models:

1. SigenStack BC M2-0.5C
2. SigenStack BC M2-1C-BST
3. SigenStack BC M2-0.5C-BST

**M2: Support 1250V input Voltage**

can connect more batteries when M2 inverter is configured

**BST: With DC-DC Boost Module**

Use it when number of battery module ≤ 19

Use it for PV + ESS (DC coupling) projects

## Type of SigenStack Base



SigenStack Base SUB-0.5C

SigenStack Base SUB-1C



SigenStack Base MAIN-0.5C

SigenStack Base MAIN-1C



SigenStack Base 4S-0.5C

# 0.5C Scenario, System Scale - (241kWh ~ 253kWh)

## 0.5C Scenario 3

229kWh

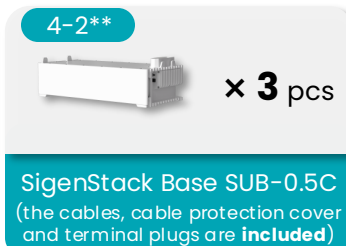
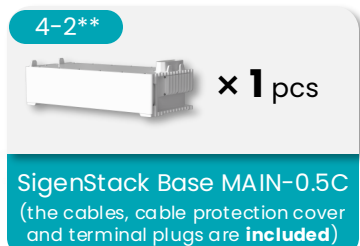

## Recommended System Configuration

Capacity (kWh)	Packs	Packs of SUB Stack 3	Packs of SUB Stack 2	Packs of SUB Stack 1	Packs of MAIN Stack	Cover	Recommended inverters
241	20	5	5	5	5	3	Sigen PV 125MI-HYA
253	21	6	5	5	5	3	Sigen PV 125MI-HYA

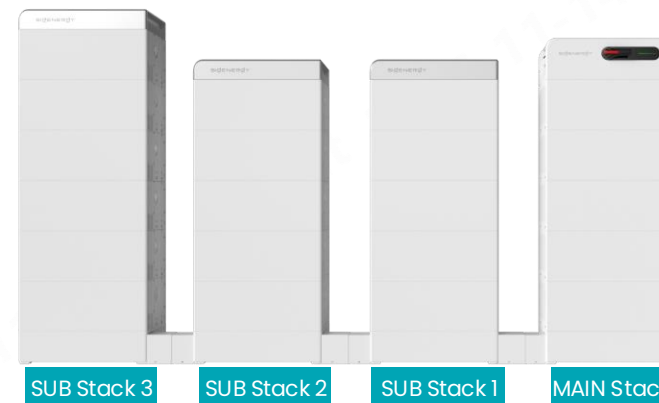

\*Note: For PV+ESS DC coupling system, Battery controller should always use the model with "BST" (SigenStack BC M2-0.5C-BST)

\*\*Note: Please choose either Option 4-1 or 4-2. Option 4-1 is more suitable for the standard design of large-scale projects, while Option 4-2 is more appropriate for stockpiling in small-scale C&I businesses

# Great savings on both installation space & electricity bills



Timrå, Sweden

AC Output Power

**140** kW<sub>ac</sub>

ESS capacity

**280** kWh

Footprints in *corridor*

**6.83** m<sup>2</sup>

Virtual expansion in heavy machinery factory

Participation in VPP



# On-grid Solar + ESS system for a Mine in Spain



Cáceres, Spain



PV capacity

**200** kWp

ESS capacity

**400** kWh

AC Output Power

**250** kWac

Electricity bill savings

**68,610** Euros/year

Estimated annual generation

**320,000** kWh

# Sigenergy Industrial ESS on Manufacturing Center



China (Shanghai) Lingang New Area

Estimated annual power generation **398,200** kWh

Save on electricity expenses **32,000** Euro/year

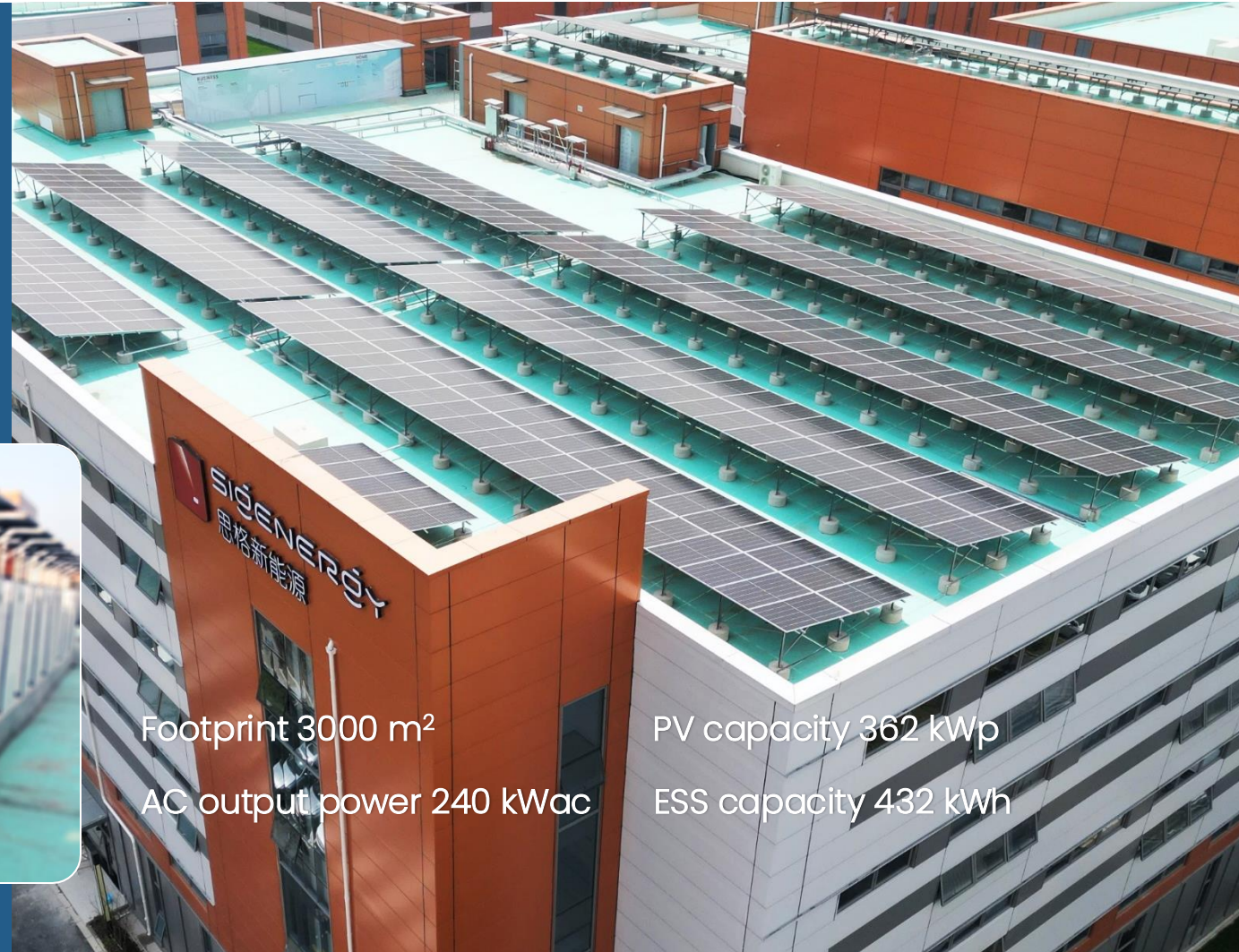

Footprint 3000 m<sup>2</sup>

AC output power 240 kWac

PV capacity 362 kWp

ESS capacity 432 kWh

# Hybrid Solar + ESS System in of a Government Project

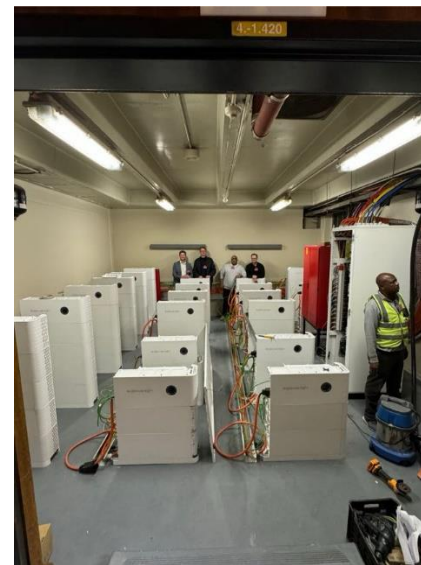

Durban, South Africa

ESS capacity

**528** kWh

AC Output Power

**300** kWac

Estimated annual generation

**504,000** kWh

Diesel cost savings

3,900,164 ZAR/year

**213,768** USD/year

*Power backup and cutting energy bills*