

Tiled roof | Tongue and groove boards

Always follow the assembly instructions in the Nordmount Planner, Nordmount's configurator.

Mounting kit

Art no 1357 – NM Hyper Meta

Art no 1916 – NM Hyper Rail Silver

Art no 1919 – NM Hyper Joint Rail Silver

Art no 3131 – NM Hyper Mid/End Clamp Silver

Art no 2919 – NM Hyper End Cap

Art no 1308 – NM Hex 8 Socket

Art no 63191000 – NM Screw

Alternative 1 minimum dimension tongue and groove 17 mm

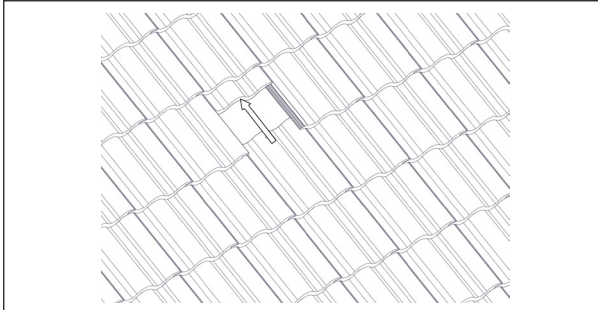

1.

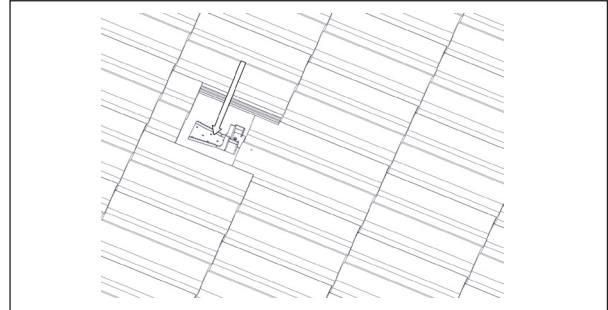

2.

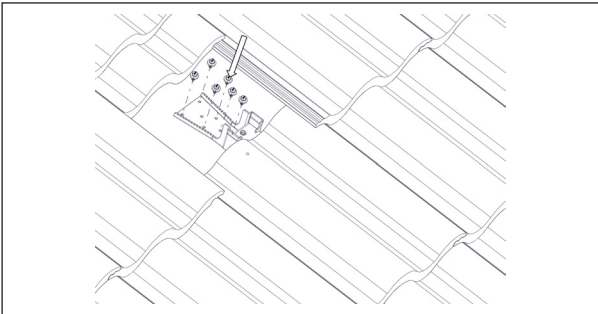

3. Use 6 pc NM Wood Screw.

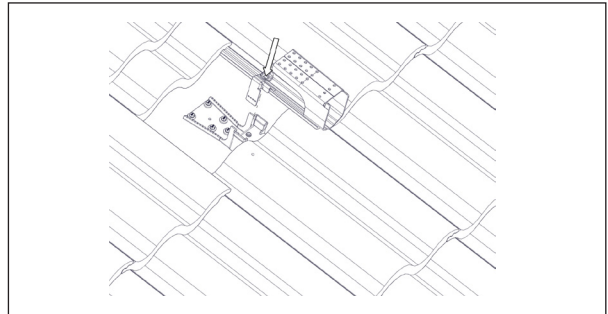

4. Tighten the screw with Hex 8 until you make contact with the pan.

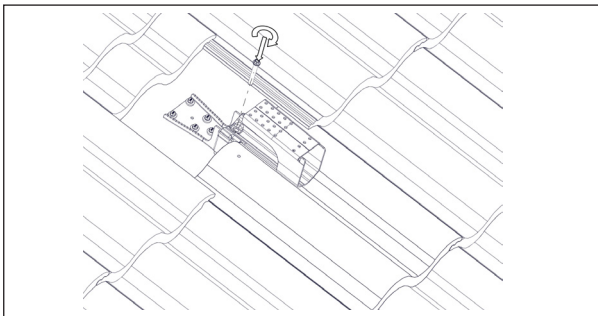

5.

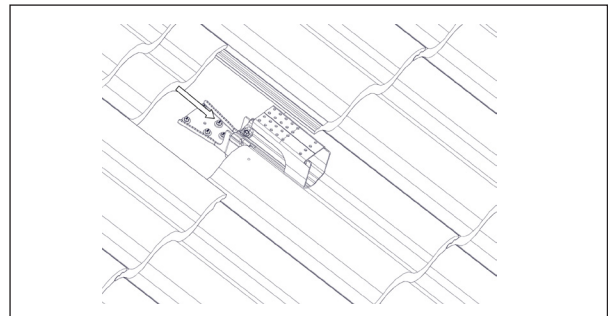

6.

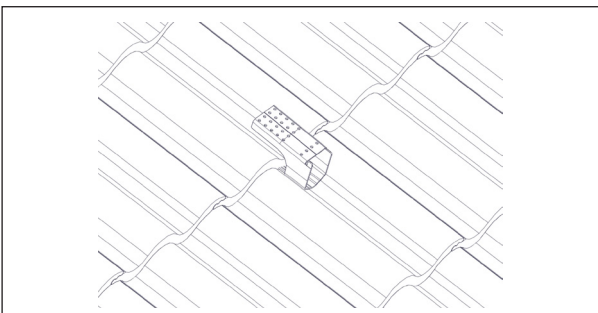

7.

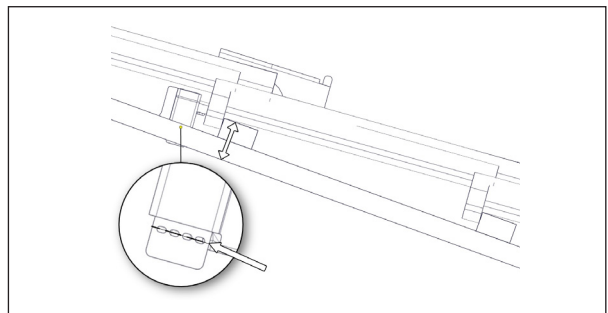

8. If batten and counter batten thickness is less than 46 mm, break off the legs at the NM Hyper Meta bracket.

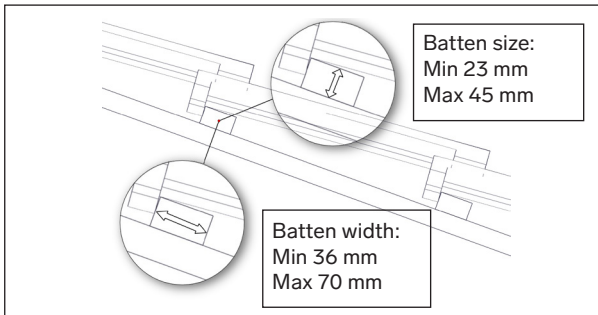

9.

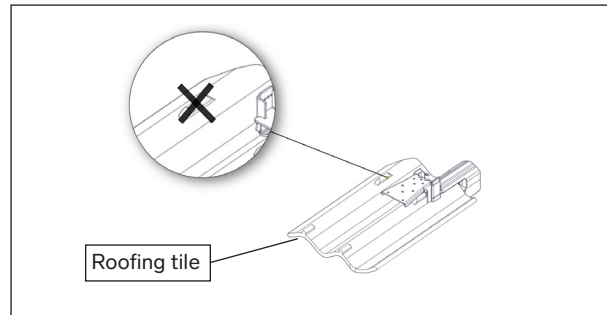

10. When installing roofing tiles, break off the lower pins on the tiles when installing the Hyper Meta bracket.

Alternativ 2 - minimum dimension tongue and groove 17 mm

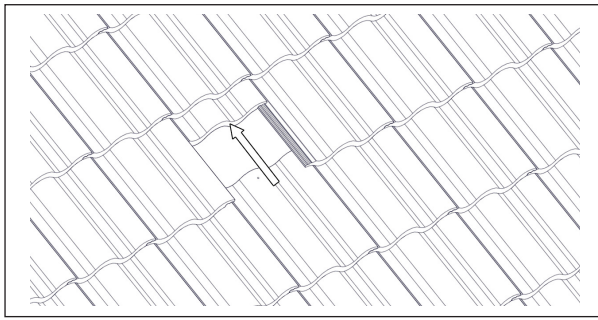

1.

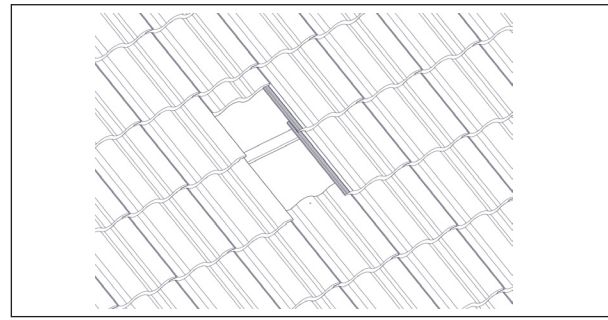

2.

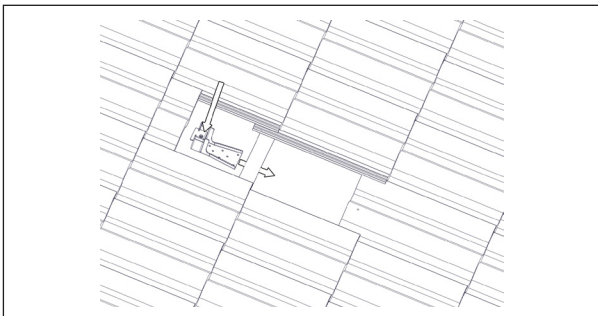

3.

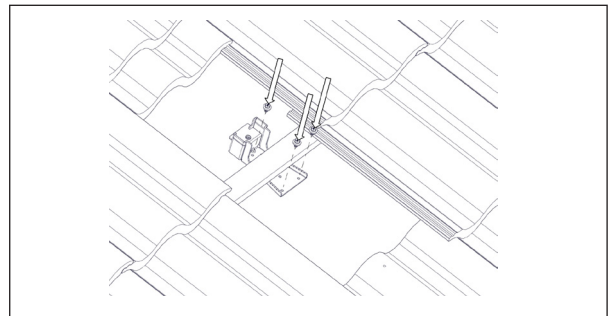

4. Use 3st NM Wood Screw.

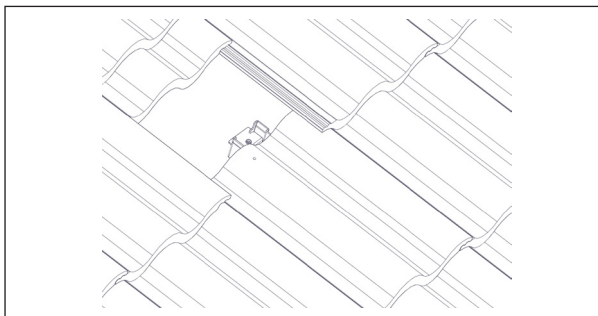

5.

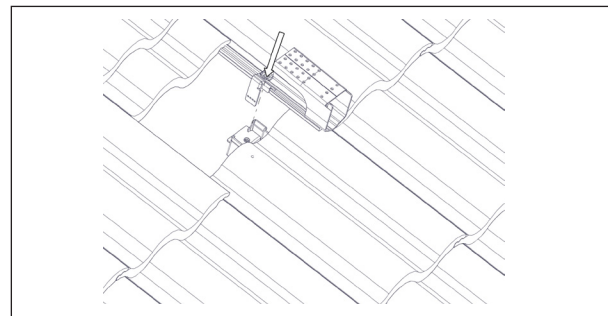

6.

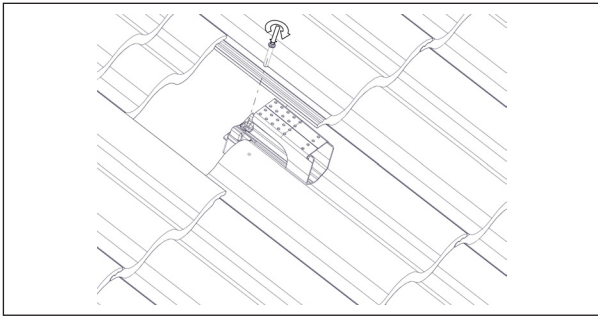

7. Tighten the screw with Hex 8 until you make contact with the pan.

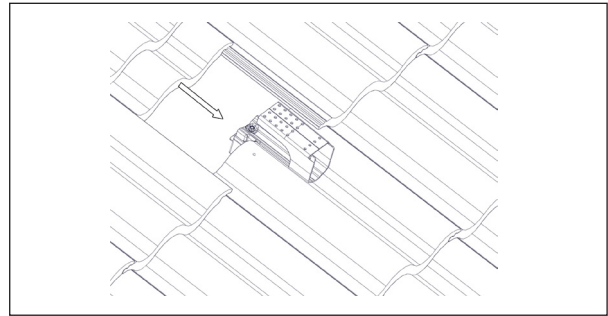

8.

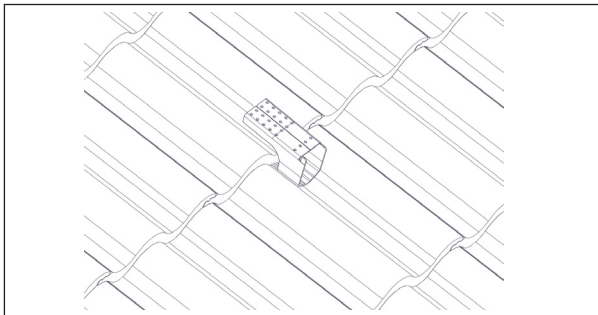

9.

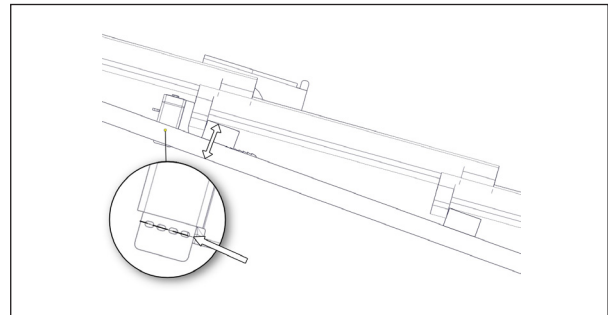

10. If batten and counter batten thickness is less than 46 mm, break off the legs at the NM Hyper Meta bracket.

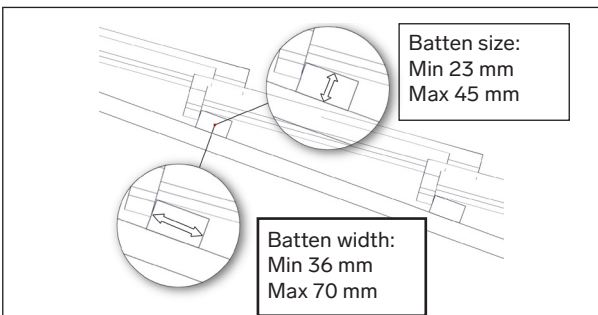

11.

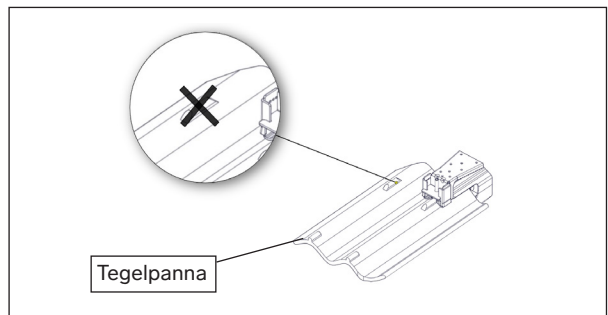

12. When installing roofing tiles, break off the lower pins on the tiles when installing the Hyper Meta bracket.

Installation, horizontal rail

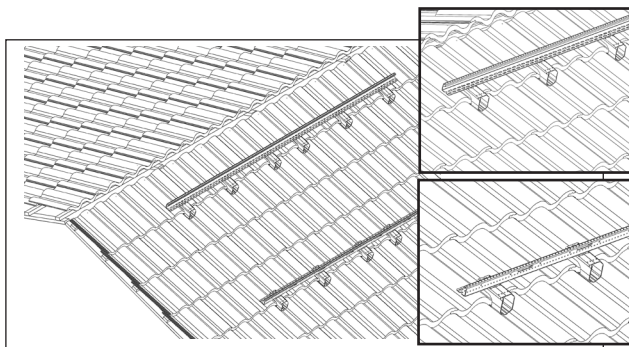

13. For easier handling when attaching panels: The rail closest to the ridge is mounted with its back facing the ridge. Then every second rail is mounted with the back in the opposite direction. It is also possible to mount all rails with the back against the ridge.

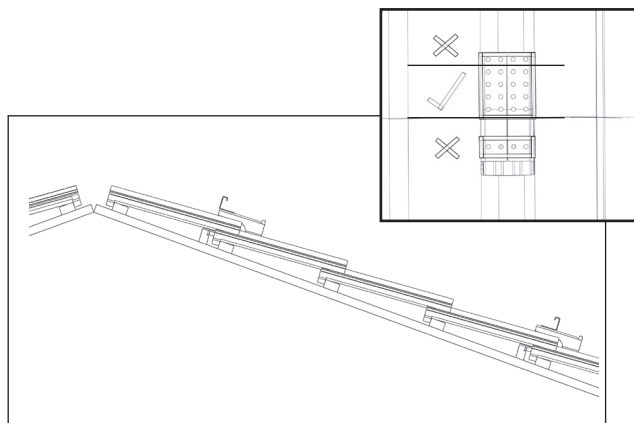

14. Always follow the hole instructions when installing horizontal rails. Exception: If the back of the rail faces the eave, the top holes may also be used.

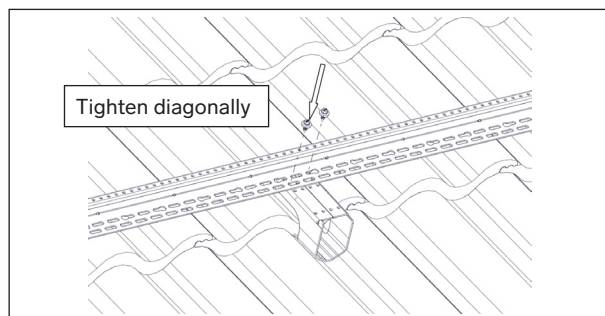

15. Screw in two NM Screws diagonally, one on each side of the open slot at the top edge of the bracket.

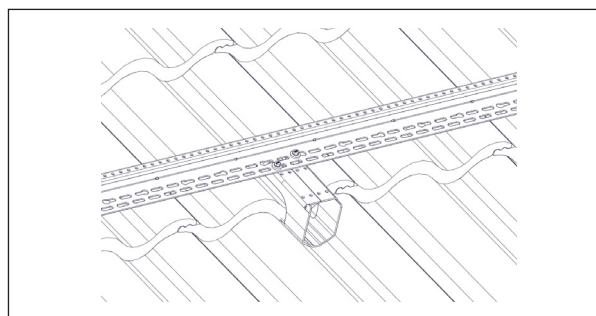

16.

Installation, upright rail

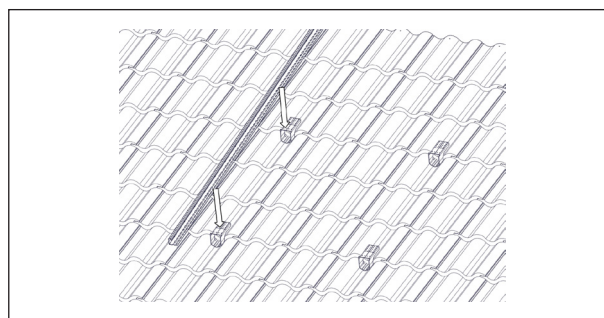

13.

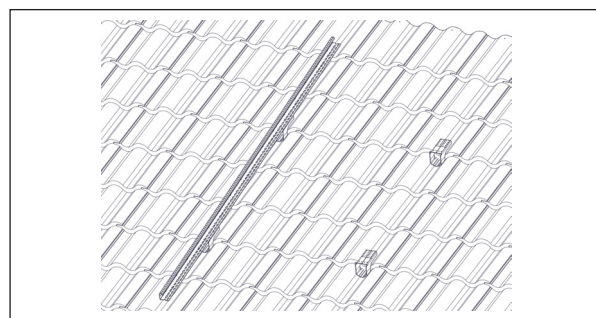

14.

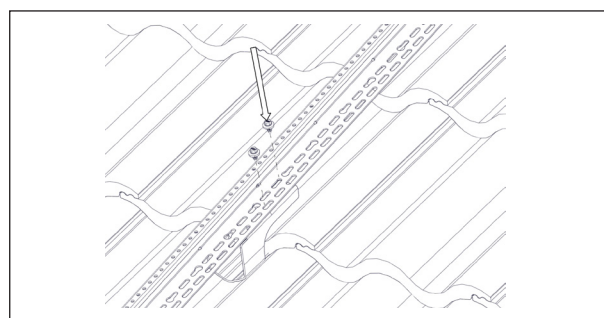

15.

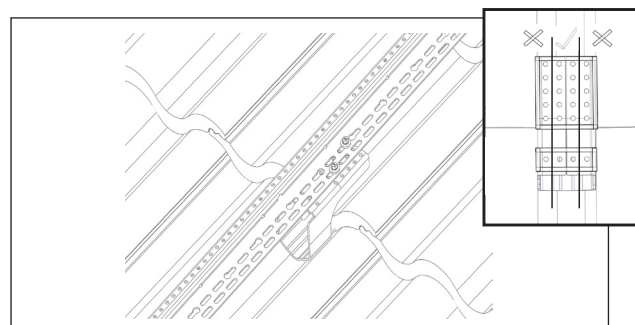

16. Mount in the two innermost rows of holes, it can be attached to the entire row of holes. Screw two NM Screw diagonally.

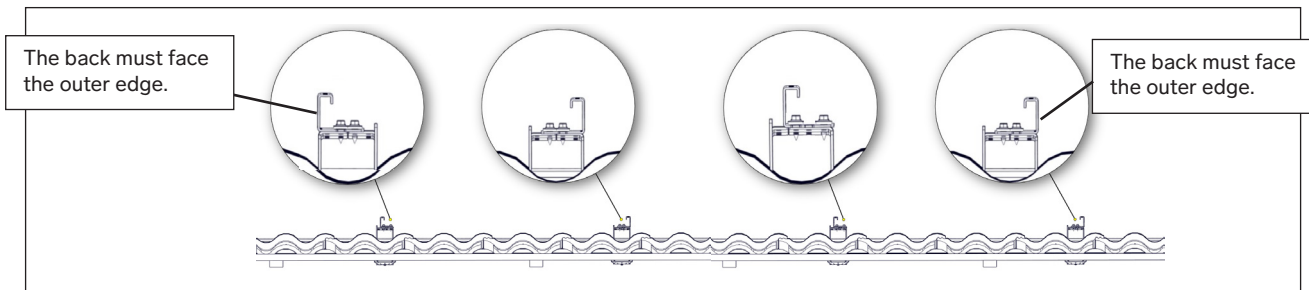

17. For upright installation, the back of the outer rails must face the outside edge of the roof. Then every second rail is mounted with the back in the opposite direction. Fasten a screw in each Meta bracket 'lip'; tighten diagonally.

Cross installation

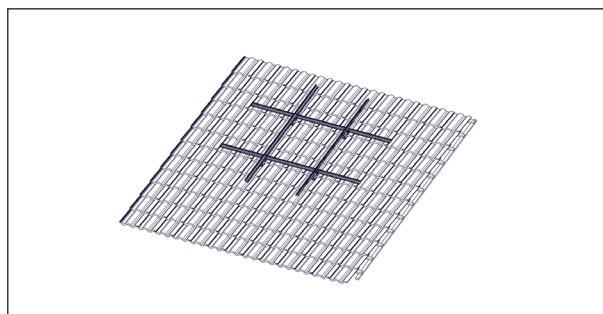

9.

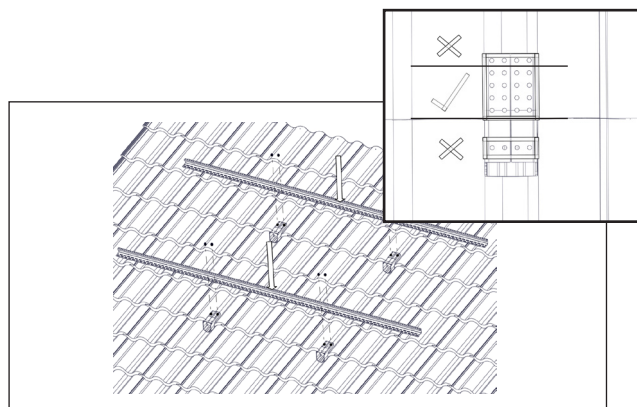

10. Note, mount only according to the hole instructions at the first horizontal rail.

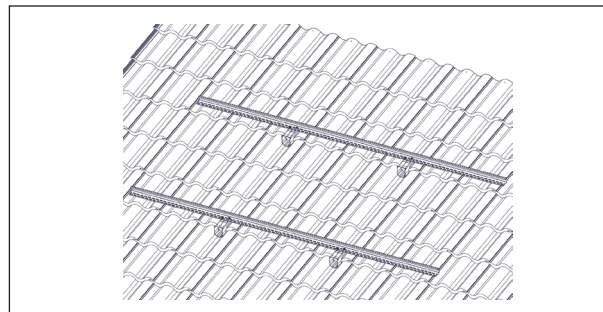

11. For easier handling when attaching panels: The rail closest to the ridge is mounted with its back facing the ridge. Then every second rail is mounted with the back in the opposite direction. It is also possible to mount all rails with the back against the ridge.

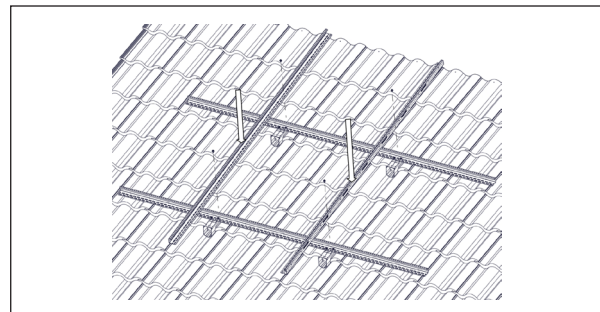

12. Mount the upper rail with preferably two NM Screws according to the drawing from the Nordmount Planner.

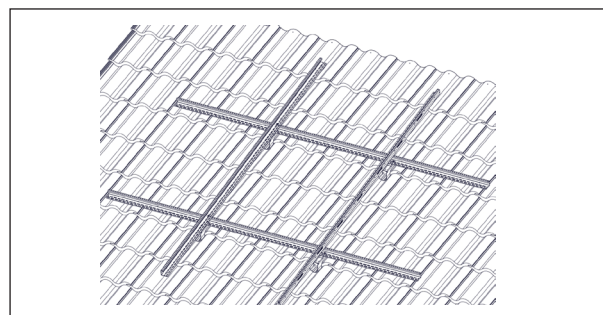

13. When cross-mounted, the vertical and outermost rail must have its back towards the outer edge of the roof. See picture 14.

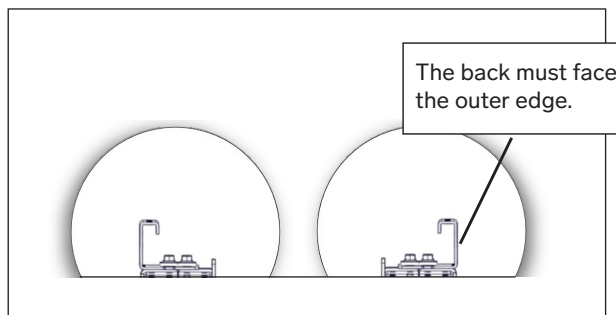

14. In cross installation, the back of the upright and outermost rail must face the outer edge of the roof.

Extension of rail

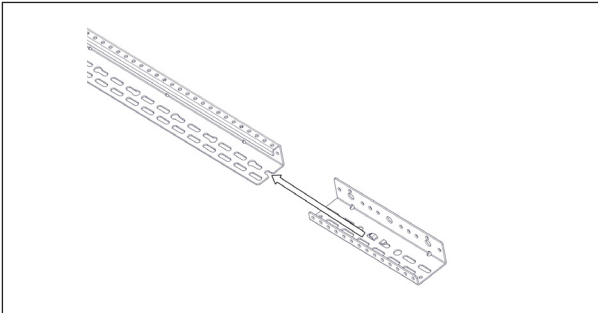

18.

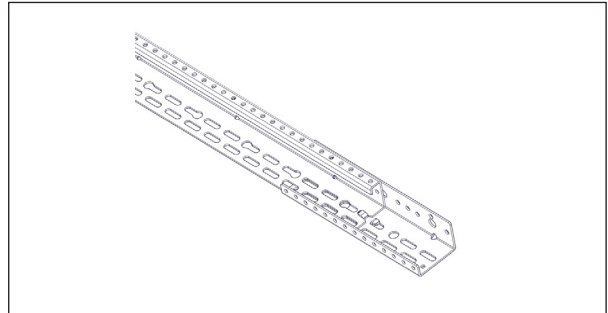

19.

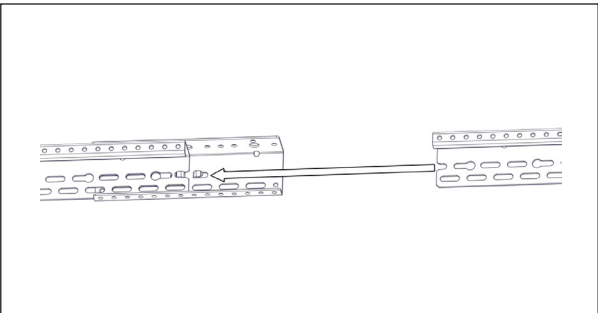

20.

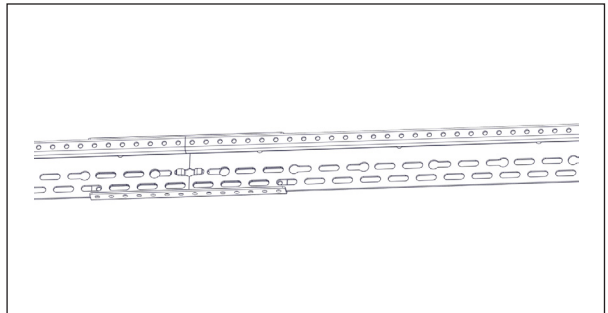

21.

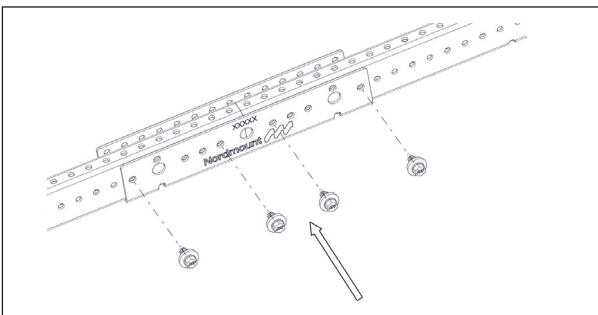

22. Fasten in total with 4 Nm Screws, 2 per side/rail.
There are 4 holes per side to choose from.

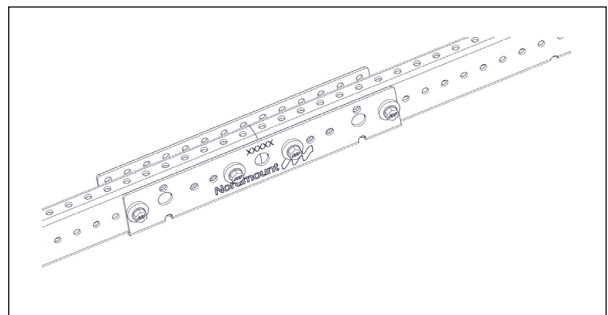

23.

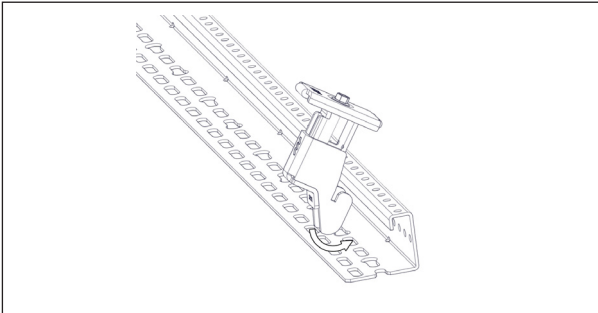

24.

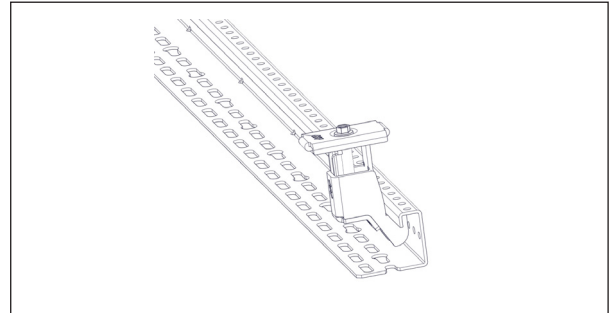

25.

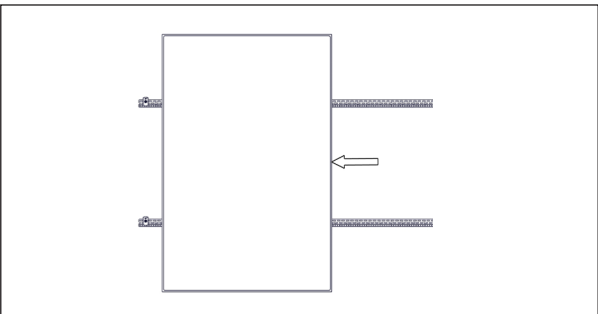

26. Note that there may be a maximum of 35cm overhang on the rail from the last attachment.

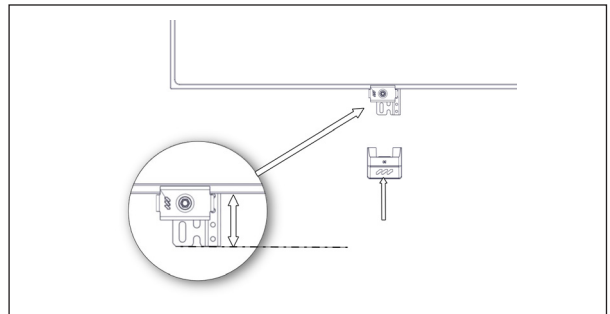

27. When end caps are attached, the rail's protrusion from the panel may have these dimensions: min 35 mm - max 63 mm.

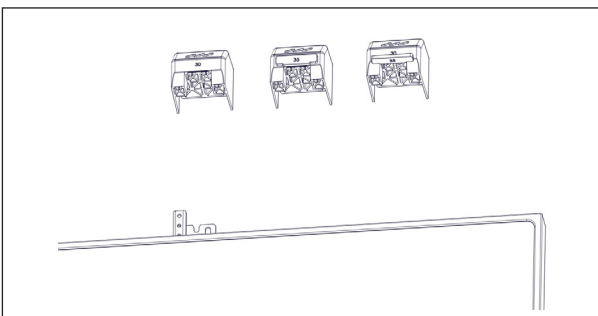

28.

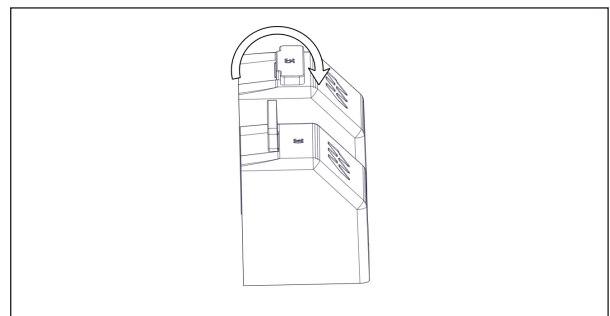

29. For 30 mm solar panel heights, break off the tab on the NM Hyper End Cap. For 35 mm solar panel heights, fold the tab on the NM Hyper End Cap.

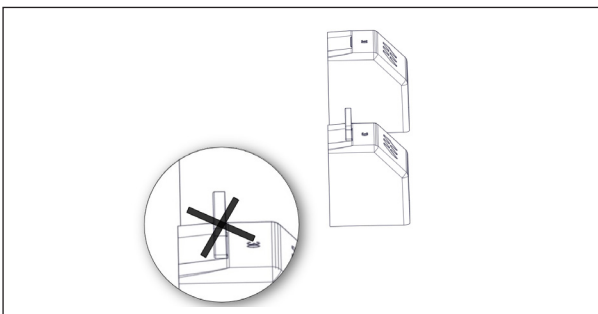

30.

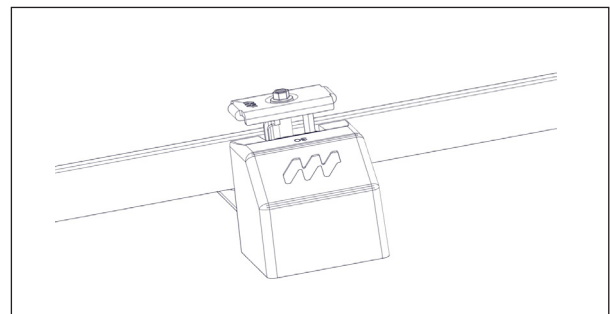

31.

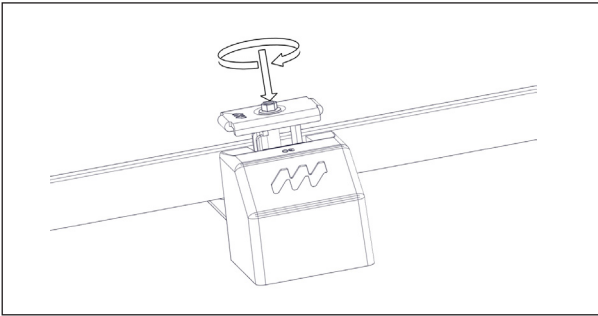

32. Tightening torque 10 Nm. A tip at this point is to use your hand as a support on the end cap.

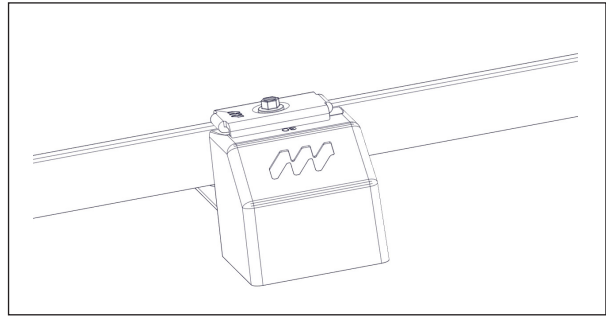

33. Make sure the bracket is securely attached to the end cover for safe attachment.

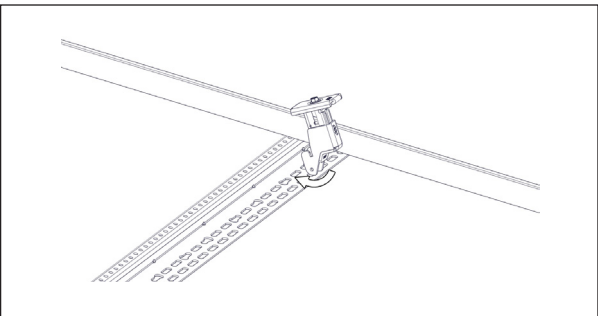

34.

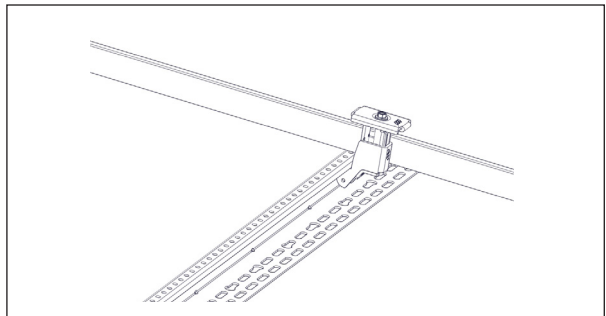

35.

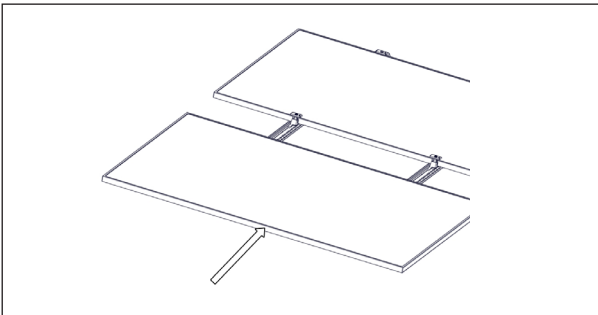

36.

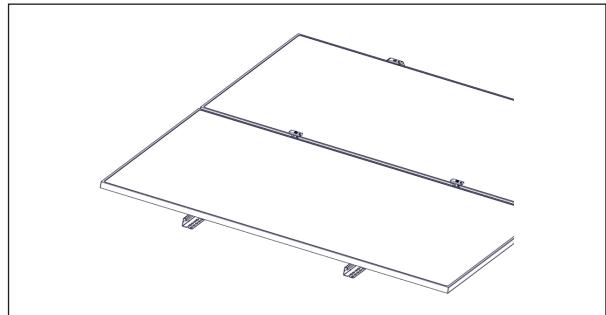

37.

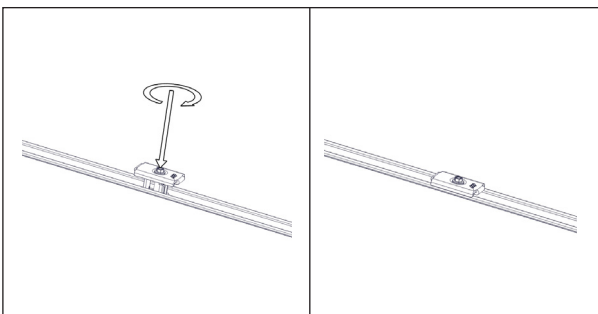

38. Tightening torque 10 Nm.

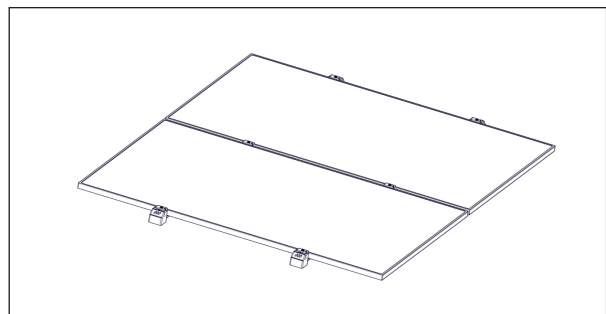

39.